

**ENERGY CONSUMPTION ANALYSIS OF ELECTRIC VEHICLE BASED
ON DRIVING CYCLES OF THAILAND**

BONGKOTCHAPORN DUANGSRIKAEW

**A THESIS REPORT SUBMITTED IN PARTIAL FULFILLMENT
OF THE REQUIREMENTS FOR THE DEGREE OF
MASTER OF ENGINEERING IN AUTOMOTIVE ENGINEERING
INTERNATIONAL COLLEGE**

KING MONGKUT'S INSTITUTE OF TECHNOLOGY LADKRABANG

ACADEMIC YEAR 2018

KMITL-2018-IC-M-004-001

**ENERGY CONSUMPTION ANALYSIS OF ELECTRIC VEHICLE BASED
ON DRIVING CYCLES IN THAILAND**



**A THESIS REPORT SUBMITTED IN PARTIAL FULFILLMENT
OF THE REQUIREMENTS FOR THE DEGREE OF
MASTER OF ENGINEERING IN AUTOMOTIVE ENGINEERING
INTERNATIONAL COLLEGE
KING MONGKUT'S INSTITUTE OF TECHNOLOGY LADKRABANG
ACADEMIC YEAR 2018
KMUTL-2018-IC-M-004-001**

This material is reserved for educational use only, not allowed for commercial use.
Forbidden to modify the content, and cite the document when use.



This material is reserved for educational use only, not allowed for commercial use.
Forbidden to modify the content, and cite the document when use.

THESIS TITLE Energy Consumption Analysis of Electric Vehicle based on Driving Cycles in Thailand
STUDENT NAME Miss Bongkotchaporn Duangsrikaew
STUDENT ID 58610053
DEGREE Master of Engineering
PROGRAMME Automotive Engineering
ADVISOR Asst.Prof.Dr.Preechar Karin
CO-ADVISOR Dr.Chi-na Benyajati
CO-ADVISOR Prof.Katsunori Hanamura

ABSTRACT

Rising population in suburban area have led to an increasing demand for commuter buses. Coupled with a desire to reduce pollution from daily routine of traveling and transportation, the electric vehicle has become more interesting as an alternative placement for internal combustion engine vehicles. However, in comparison to those conventional vehicles, electric vehicles have an issue of limited driving range. One of main challenges in designing EV is to estimate the size and power of energy storage system, i.e. battery pack, for any specific application. A reliable information on energy consumption of vehicle of interest is therefore necessary for a successful EV implementation in terms of both performance and cost. However, energy consumption usually depends on several factors such as traffic conditions, driving cycle, velocities, road topology, etc. This paper presents an energy consumption analysis of electric vehicle in three different route types i.e. closed-area, inter-city, and city operated by campus tram and shuttle bus. First, the driving data of NGV campus trams operating in a university located in suburban of Bangkok and the driving data; shuttle buses operating in suburban and in-city were collected and used as a reference. The real driving cycle data i.e. velocity and vehicle global position (latitude, longitude, including road slope) were collected through a GPS-based equipment, V Box (VB20SL3, Racelogic Ltd). Next, the driving data from a campus tram for different service routes were gathered to compute the energy consumption using MATLAB/Simulink. As a result, the calculated energy consumptions were discussed for analyzing the proper EV performance with available preliminary specifications and planning in each route.

This material is reserved for educational use only, not allowed for commercial use.

Forbidden to modify the content, and cite the document when use.

ACKNOWLEDGEMENT

The authors would like to thank Thailand Advance Institute of Science and Technology, Tokyo Institute of Technology (TAIST-Tokyo Tech) and National Science and Technology Development Agency (NSTDA) for providing full scholarship, Thailand Graduate Institute of Science and Technology (Grant No. NUI-RC-M33-22-59-010M), and also thank the Lightweight Engineering Laboratory, National Metal and Material Technology Center (MTEC), Phanthong Alliance Co., LTD, Mahidol University and KMITL International College for their great supports in this work.

Bongkotchaporn Duangsrikaew



This material is reserved for educational use only, not allowed for commercial use.

Forbidden to modify the content, and cite the document when use.

TABLE OF CONTENTS

Chapter	Page
ABSTRACT.....	I
ACKNOWLEDGEMENT	II
TABLE OF CONTENTS.....	III
LIST OF TABLES.....	VI
LIST OF FIGURES	VIII
LIST OF SYMBOLS	X
LIST OF DEFINITIONS	XII
CHAPTER 1 INTRODUCTION	1
1.1 Background.....	1
1.2 Objectives	3
1.3 Thesis Outlines	3
CHAPTER 2 LITERATURE REVIEW	4
2.1 Driving Cycles.....	4
2.1.1 Definition of Driving Cycle	4
2.1.2 Driving Cycles Standardized Format	5
2.1.3 The Use of Driving Cycle	6
2.1.4 Route Selection	8
2.1.5 Driving Data Collection Techniques.....	8
2.1.6 Data Segmentation	9
2.1.7 Methodologies of Driving Cycle Construction.....	9
2.2 Electric Vehicle Energy Consumption	10
2.2.1 Energy Consumption Measurement.....	10
2.2.2 Simulation by using Matlab	11
2.3 Energy Storage Unit	11
2.3.1 Battery	12
2.3.2 Ultracapacitor (UC).....	13
2.3.3 Flywheels	13
2.3.4 Hydrogen Energy	14

This material is reserved for educational use only, not allowed for commercial use.

Forbidden to modify the content, and cite the document when use.

TABLE OF CONTENTS (CONT.)

Chapter	Page
CHAPTER 3 RESEARCH METHODOLOGY	15
3.1 Operation Routes	15
3.1.1 Closed-Area Route Operated by Tram.....	15
3.1.2 City route operated by shuttle bus.....	15
3.1.3 Inter-City route Operated by Shuttle Bus and Salaya Link Bus	16
3.2 Data Collection	17
3.3 Driving Cycle Development.....	18
3.3.1 Collected Driving Data Characteristics.....	18
3.3.2 Microtrip Data Segmentation.....	19
3.3.3 Driving Cycle Construction	21
3.3.4 Generated Driving Cycle.....	23
3.4 Energy Consumption Calculation.....	24
3.4.1 Traction Energy Consumption.....	24
3.4.2 Total Energy Consumption.....	26
3.5 Battery Sizing	28
3.5.1 Battery Sizing for Campus Bus Operation.....	28
3.5.2 Battery Sizing Estimated Using a Fixed Vehicle Range Approach.....	31
CHAPTER 4 RESULTS	34
4.1 Driving Cycle Development.....	34
4.1.1 Percentage error of representative generated driving cycles.....	34
4.1.2 Representative of Generated Driving Cycle.....	36
4.2 Energy Consumption	42
4.2.1 Traction energy consumption.....	42
4.2.2 Total Energy Consumption	43
4.3 Battery Sizing	44
4.3.1 Battery Sizing for Campus Bus Operation Design.....	45
4.3.2 Battery Sizing Estimated using a Fixed Vehicle Range Approach.....	48
CHAPTER 5 DISCUSSION.....	51
5.1 Driving Cycle.....	51
5.2 Energy Consumption	52
5.3 Battery Sizing	53

This material is reserved for educational use only, not allowed for commercial use.

Forbidden to modify the content, and cite the document when use.

TABLE OF CONTENTS (CONT.)

Chapter	Page
CHAPTER 6 CONCLUSIONS AND RECOMMENDATIONS	55
REFERENCES	57
APPENDIX A VBOX GPS EQUIPMENT SPECIFICATION.....	59
APPENDIX B DRIVING CYCLE CHARACTERISTIC	61
APPENDIX C PERCENTAGE ERROR OF GENERATED DRIVING CYCLE.....	65
APPENDIX D PERCENTAGE ERROR OF REPRESENTATIVE DRIVING CYCLE	69
APPENDIX E TRAM STATION OPERATION	70
APPENDIX F SHUTTLE BUS OPEARTION TIMETABLE.....	74
APPENDIX G SALAYA LINK OPERATED TIMETABLE.....	76
APPENDIX H BATTERY AND CHARGING STATION COST FOR CAMPUS BUS OPERATION	77
APPENDIX I BATTERY AND CHARGING STATION COST FOR FIX VEHICLE RANGE.....	78
AUTHOR BIOGRAPHY.....	81

This material is reserved for educational use only, not allowed for commercial use.

Forbidden to modify the content, and cite the document when use.

LIST OF TABLES

Table	Page
Table 2.1 The details for the standardized driving cycle groups	5
Table 2.2 Example of standard driving cycles	6
Table 2.3 Summary of studies of real world driving cycles in the literatures.	7
Table 2.4 The driving cycle construction methods.....	9
Table 2.5 The comparison of different batteries types (Tie & Tan, 2013)	12
Table 3.1 Data collected in closed-area routes operated by trams.....	15
Table 3.2 Data collected in city routes operated by shuttle bus routes.....	16
Table 3.3 Data collected in inter-city routes operated by shuttle buses.....	16
Table 3.4 Data collected in inter-city routes operated by Salaya Link buses	17
Table 3.5 Data collection setup details	17
Table 3.6 Closed-area operating characteristics per cycle for each route.....	19
Table 3.7 Inter-city operating characteristics per cycle for each route.....	19
Table 3.8 City operating characteristics per cycle for each route.....	19
Table 3.9 Parameters for energy consumption calculation.....	25
Table 3.10 Parameters of main EV components and auxiliary system for energy consumption calculation	27
Table 3.11 Battery price and charger unit price.....	33
Table 4.1 Collected driving characteristic of representative routes from GPS.....	34
Table 4.2 Closed-area representative driving cycles characteristics	37
Table 4.3 Inter-city representative driving cycles characteristics.....	39
Table 4.4 City representative driving cycles characteristics.....	41
Table 4.5 Traction energy consumption (kWh) of closed-area routes.....	42
Table 4.6 Traction energy consumption (kWh) of inter-city routes	42
Table 4.7 Traction energy consumption (kWh) of city routes.....	42
Table 4.8 Total energy consumption (kWh) of closed-area routes.....	43
Table 4.9 Total energy consumption (kWh) of inter-city routes	44
Table 4.10 Total energy consumption (kWh) of city routes	44
Table 4.11 Maximum power (<i>P_{max}</i>) in kW of representative driving cycle including total components	45
Table 4.12 The usable energy form installed battery of 100kWh, 150kWh, and 200kWh.....	45

This material is reserved for educational use only, not allowed for commercial use.

Forbidden to modify the content, and cite the document when use.

LIST OF TABLES (CONT.)

Table	Page
Table 4.13 Operation distance of each route per cycle.....	45
Table 4.14 Operation distance of each route per day.....	45
Table 4.15 The number of traction cycles (<i>N_{Traction}</i>) and number of total cycles (<i>N_{Total}</i>) for closed-area operated by tram.	47
Table 4.16 The number of traction cycles (<i>N_{Traction}</i>) and number of total cycles (<i>N_{Total}</i>) for inter-city operated by shuttle bus.	47
Table 4.17 The number of traction cycles (<i>N_{Traction}</i>) and number of total cycles (<i>N_{Total}</i>) for inter-city operated by Salaya Link.	47
Table 4.18 The number of traction cycles (<i>N_{Traction}</i>) and number of total cycles (<i>N_{Total}</i>) for city operated by shuttle bus.....	47
Table 4.19 Battery and charging stations cost for closed-area, inter-city, and city.....	48
Table 4.20 The charging station location under varied the battery sizes.....	48
Table 4.21 Number of charging stations for 50 km.....	49
Table 4.22 Number of charging stations for 100 km.....	49
Table 4.23 Number of charging stations for 150 km.....	49
Table 4.24 Number of charging stations for 200 km.....	49

This material is reserved for educational use only, not allowed for commercial use.

Forbidden to modify the content, and cite the document when use.

LIST OF FIGURES

Figure	Page
Figure 1.1 The core aspects of electric vehicle.....	1
Figure 1.2 Electric car sales, market share, BEV, and PHEV sales shares in selected countries, 2010-2016.....	2
Figure 2.1 Steps for driving cycle development	4
Figure 2.2 Types of driving cycle	5
Figure 2.3 Electrical power measuring and recording device.....	11
Figure 3.1 Closed-area routes operated by trams.....	15
Figure 3.2 City routes operated by shuttle buses	16
Figure 3.3 Inter-city routes operated by shuttle buses	16
Figure 3.4 Inter-city routes operated by Salaya Link buses.....	17
Figure 3.5 Driving cycle development process.....	18
Figure 3.6 Microtrip Separation Process	20
Figure 3.7 Example of microtrips segmentation from a speed-time data.....	20
Figure 3.8 Driving cycle construction procedure flow chart.....	22
Figure 3.9 The example of generated of driving cycle.	23
Figure 3.10 MATLAB Simulink for energy consumption calculation.....	26
Figure 3.11 Main EV components and auxiliary system load.....	27
Figure 3.12 Proposed location of campus bus charging station locations.....	29
Figure 4.1 Calculated percentage error in time, distance, and idle from generated driving cycles for closed-area and inter-city routes using NM method.....	35
Figure 4.2 Calculated percentage error in time, distance, and idle from generated driving cycles for inter-city and city routes using TM method	36
Figure 4.3 Generated representative driving cycle (Closed-area) (a) Route 1 (b) Route 2 (c) Route 3 and (d) Route 4.....	38
Figure 4.4 Representative driving cycle (Inter-city) (a) S-Si, (b) Si-S, (c) S-W, (d) W-S, and Salaya Link	40
Figure 4.5 Representative driving cycle (City) (a) Si-W and (b) W-Si.....	41
Figure 4.6 Traction energy consumption (kWh/km) of closed-area, inter-city and city routes.....	43
Figure 4.7 Total energy consumption (kWh/km) of closed-area, inter-city and city routes.....	44

This material is reserved for educational use only, not allowed for commercial use.

Forbidden to modify the content, and cite the document when use.

LIST OF FIGURES (CONT.)

Figure	Page
Figure 4.8 Estimated battery capacity of traction and total energy demanded per day for closed-area, inter-city, and city	46
Figure 4.9 Battery and charging station cost	50



This material is reserved for educational use only, not allowed for commercial use.

Forbidden to modify the content, and cite the document when use.

LIST OF SYMBOLS

V_{sd}	Average velocity standard deviation
V_{avg}	Average velocity (km/h)
V_{max}	Maximum velocity (km/h)
T_{limit}	Average time per cycle (s)
T_{range}	Speed range limit time (s)
T_{gen}	Generated speed range time (s)
N	Number of microtrips in each speed range (%)
T	Time spent in microtrips of each speed ranges (%)
E_n	The error of speed range n-th, $n = 1, 2, \dots, 8$ (%)
W_{a-b}	Weight factor for each speed range 0-10 km/h, ..., and 70-80 km/h
E	The total of error (%)
F	The tractive force (N)
R_a	The aerodynamic resistance (N)
R_r	The rolling resistance (N)
R_{cl}	Grade resistance (N)
v	Velocity (m/s^2)
C_d	Coefficient of drag
ρ	Air density (kg/m^3)
A	Frontal area of vehicle (m^2)
f_r	Rolling resistance constant
g	Gravity acceleration ($9.81 m/s^2$)
m	A mass of vehicle (kg)
θ	The road grade (degree)
P	Power (Watt)
t	Time (s)
E_t	Traction energy consumption (kWh)
D_{avg}	Average distance per cycle (km)
$E_{Traction}$	Traction energy consumption rate (kWh/km)
P_c	EV components and auxiliary system load (kW)
E_c	Energy consumption of main EV components and auxiliary system (kWh)

This material is reserved for educational use only, not allowed for commercial use.

Forbidden to modify the content, and cite the document when use.

LIST OF SYMBOLS (CONT.)

E_T	Total energy consumption (kWh)
E_{Total}	Total energy consumption rate (kWh/km)
$E_{battery}$	The usable of battery (kWh)
η	Efficiency of LFP battery
D_{day}	Operation distance per day (km)
N_{cycle}	Number of operation cycles per day (cycles)
$E_{required,t}$	Traction energy consumption for battery sizing (kWh)
$E_{required,total}$	Total energy consumption for battery sizing (kWh)
$N_{Traction}$	Number of traction cycles. (cycles)
N_{Total}	Number of total cycles. (cycles)
<i>Battery size</i>	Installed battery size (kWh)
$D_{charger,t}$	The distance of located charging station for traction driving range (km)
$D_{charger,total}$	The distance of located charging for total driving range (km)
D_{fix}	Fixed operation distance (km)
$N_{charger,t}$	The number of chargers for traction driving range
$N_{charger,total}$	The number of chargers for total driving range
$Cost_{Traction}$	Investment cost for traction driving range (THB)
$Cost_{Total}$	Investment cost for total driving range (THB)

This material is reserved for educational use only, not allowed for commercial use.

Forbidden to modify the content, and cite the document when use.

LIST OF DEFINITIONS

EV	Electric Vehicle
BEV	Battery-Electric Vehicle
PHEV	Plug-in Hybrid Electric Vehicle
BP	British Petroleum
TNO	TNO Automotive, The Netherlands. The power train and emissions research institute
FHB	Fachhochschule Biel
VRLA	Valve Regular Lead Acid
HHV	Hydraulic Hybrid Vehicle
HEV	Hybrid Electric Vehicle
SOC	State of Charge
NEDC	New European Driving Cycle
MT	Manual Transmission
UDC	Urban Driving Cycle
EUDC	Extra Urban Driving Cycle

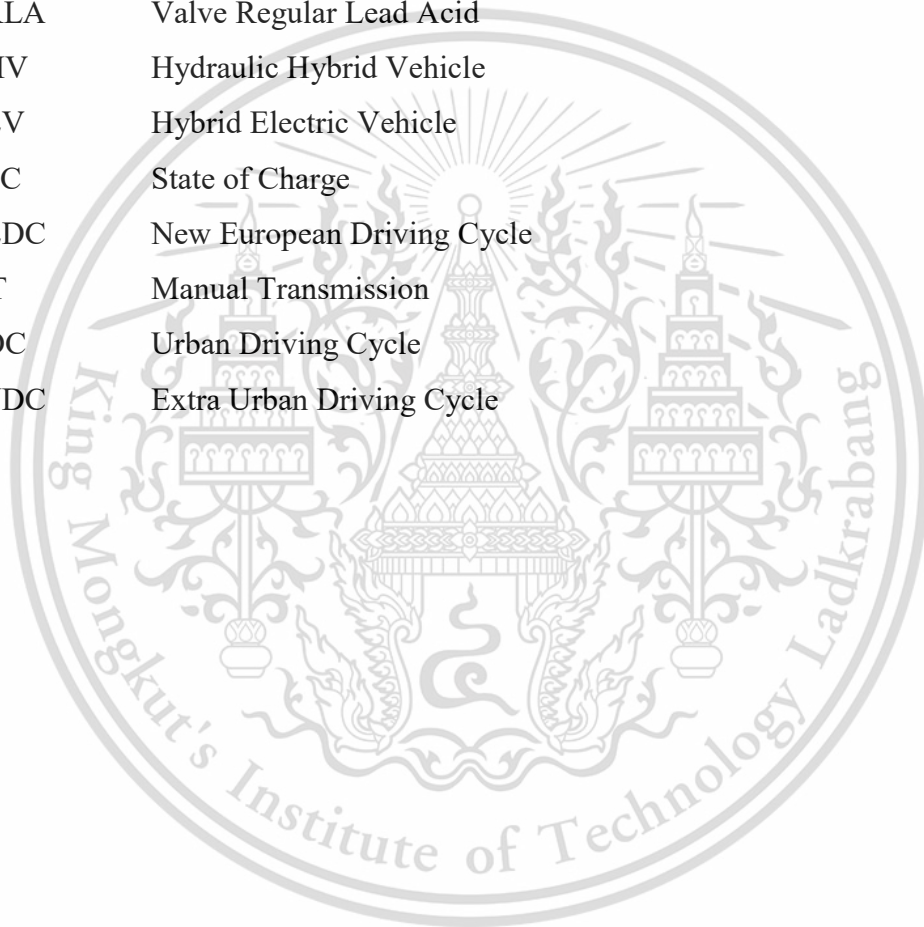

This material is reserved for educational use only, not allowed for commercial use.

Forbidden to modify the content, and cite the document when use.

CHAPTER 1

INTRODUCTION

1.1 Background

Climate change and the conditions for the use of fossil resources such as limited availability, price is causing many countries to change their national climate, energy policies. The introduction of emission-free zones in town area will speed up the expansion of electro mobility. (Volkswagen Academy, 2013) The core aspects of electric vehicle are shown in Figure 1.1.

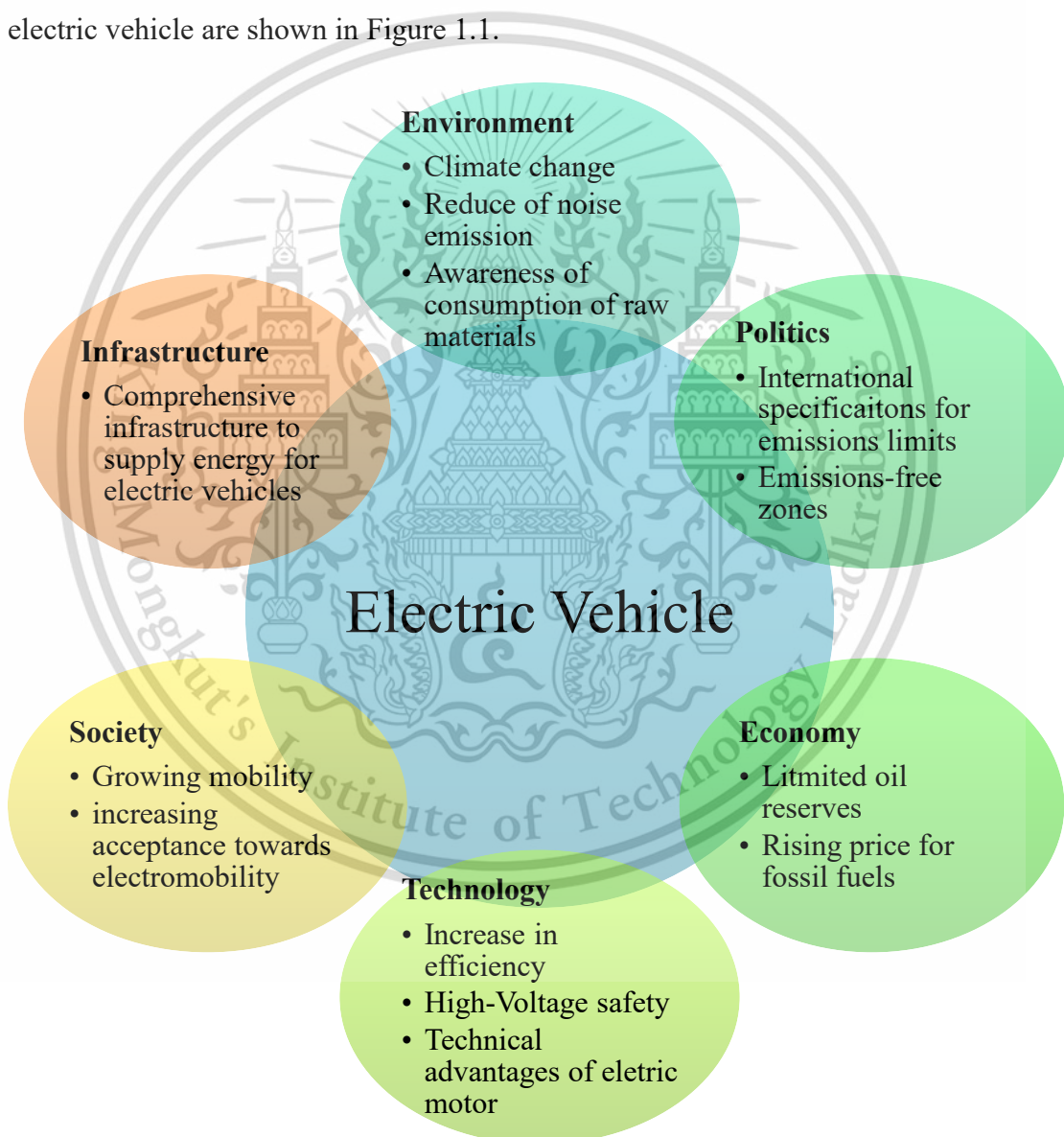

Figure 1.1 The core aspects of electric vehicle

Source: Volkswagen Academy. (2013). Basics of Electric Vehicles Design and Function. U.S.A: Volkswagen Group of America, Inc.

Forbidden to modify the content, and cite the document when use.

The electric car market is dominated by the policy environment. New registrations of electric cars reached a new record in 2016, with over 750 thousand sales worldwide (IEA, 2017) as illustrated in Figure 1.2.

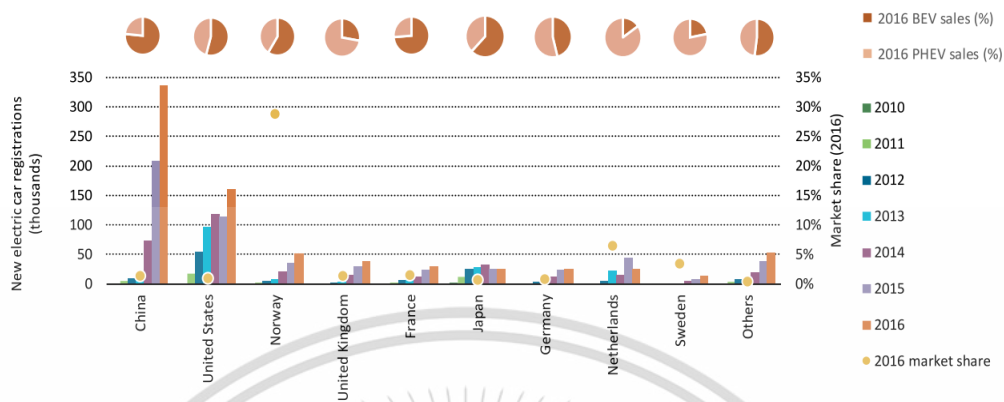

Figure 1.2 Electric car sales, market share, BEV, and PHEV sales shares in selected countries, 2010-2016

Source: IEA, I. E. A. (2017). Global EV Outlook 2017: Two million and counting. IEA Publications, 1–71. <https://doi.org/10.1787/9789264278882-en>

Mass production prospects, development, deployment (RD&D), and research are increasing in battery energy density and this rapidly decreases the battery cost. The currently developing technologies confirm that trend will continue in the area of BEV improvements. The competitive gap between EVs and internal combustion engines (ICEs) is now narrowing with advantages offered by EV such as reducing air pollution and limiting noise. The fully electric city bus can be a major public transportation supported by the research of new business model, charging infrastructure ownerships and operations (Pihlatie, Kukkonen, Halmeaho, Karvonen, & Nylund, 2015). On board vehicle power and energy management should be functions of real driving requirements. This research presents an energy consumption analysis of medium-to-large service vehicle operating in closed-area, inter-city, and city route by means of representative driving cycles in Thailand. First, the driving data of university campus tram, university inter-city shuttle bus, and university city bus (Salaya Link) operating in a campus of university situated in suburban of Bangkok were collected and used as a reference. Then, the real driving cycle data i.e. velocity and vehicle global position (latitude, longitude, including road slope) were collected through a GPS-based equipment, V Box (VB20SL3, Racelogic Ltd). Next, the calculated energy consumptions were compared between three different type of applications with proper EV performance from available preliminary specifications and planning in each route.

The materials reserved for educational use only, not allowed for commercial use.

Forbidden to modify the content, and cite the document when use.

1.2 Objectives

- To understand and analyse the real word driving cycle pattern.
- To develop a real-world driving cycle for specific area i.e. closed-area, inter-city, and city
- To analyse energy consumption analysis based on driving cycles.
- To determine minimum power and energy requirements of energy storage system for the EV bus design for operation in each specific route.

1.3 Thesis Outlines

This thesis is divided into 6 Chapters. The contents are summarized as followed:

Chapter 1: Introduction

This chapter introduces the general background of electric vehicles, scope of work, and the objectives.

Chapter 2: Literature Review

This chapter reviews the methods used for driving cycle development and electric vehicle energy consumption calculation from real-world driving data. It is divided into three main headings, driving cycle, electric vehicle energy consumption, and energy storage unit.

Chapter 3: Research Methodology

This chapter explains the details of operation routes, data collection method, driving cycle development, energy consumption calculation, and battery sizing calculation.

Chapter 4: Result

This chapter presents the representative of generated driving cycles and energy consumption of closed-area, inter-city, and city route.

Chapter 5: Discussion

Two driving cycle construction methods were compared in this chapter. The energy consumption was analysed.

Chapter6: Conclusions and recommendation

This chapter provides the comprehensive conclusions of this thesis and recommendation for the further research.

This material is reserved for educational use only, not allowed for commercial use.

Forbidden to modify the content, and cite the document when use.

CHAPTER 2

LITERATURE REVIEW

2.1 Driving Cycles

Driving cycles have been developed by various organizations from many countries. They are used performance, vehicle efficiency, energy consumption, and emission. The patterns and behaviours of driving characteristics differ depend on the area or city and country. It is therefore difficult to use one of developed driving cycle for another city, even in the same country. In this regard, this study focuses on developing three different driving cycles of closed-area, inter-city, and city by collection of real world data in specific areas. The general development of driving cycles steps from the literatures reviews is shown in Figure 2.1.

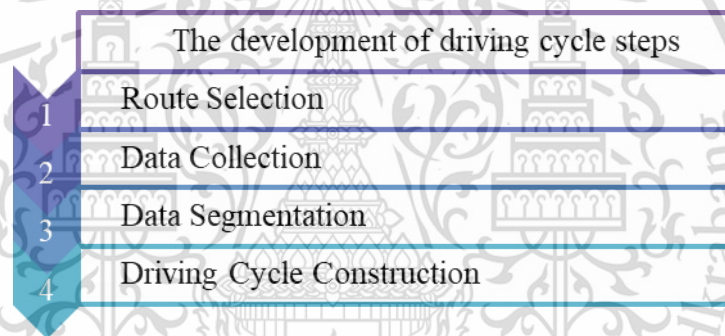

Figure 2.1 Steps for driving cycle development

2.1.1 Definition of Driving Cycle

The literature review shows that there is a collective opinion among the definition of the driving cycle. A driving cycle is defined as the series of points representing the speed of a vehicle versus time. These are established by various countries or organizations to access the vehicle performance (vehicle efficiency and fuel consumption) and some are published by the EPA as the benchmark for industry and research purpose. It is widely used in applications for vehicle manufacturers, environmentalists, and traffic engineers. A driving cycles can show an important aspect of the definition and application of driving cycles to represent different types of vehicle operation (Barlow, Latham, Mccrae, & Boulter, 2009; GHAFAR & A, 2015; Tie & Tan, 2013).

This material is reserved for educational use only, not allowed for commercial use.

Forbidden to modify the content, and cite the document when use.

2.1.2 Driving Cycles Standardized Format

There are two types of driving cycles i.e. transient driving cycle and modal driving cycle. Transient driving cycle involves many speed changes and based on typical on-road driving conditions such as UDDS and FTP. While the modal driving cycle is generated and expanded by constant speed such as NEDC, Japanese 10-15 mode and JC08 cycle (Tie & Tan, 2013). Types of driving cycle is presented in Figure 2.2.

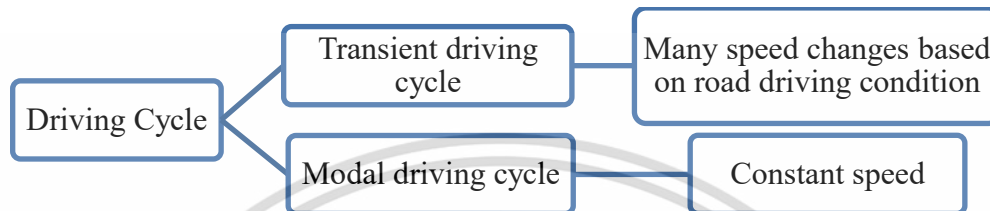

Figure 2.2 Types of driving cycle

The developed driving cycle can be grouped according to the purpose or the measurement programme. There are three international groups with standardized driving cycles which are Europe, United States, and Japan (Tie & Tan, 2013). The purpose, country, and vehicle types of driving cycle groups are given in Table 2.1.

Table 2.1 The details for the standardized driving cycle groups

Programme	Comments	Country	Vehicles
EU legislative cycles	Test cycles used for type approval purposes	European	Cars, HGVs, Buses
US cycles	A variety of test cycles from the USA including their type approval cycles	USA	Cars, HGVs, Buses
Japanese legislative cycles	Test cycles used for type approval purposes	Japan	Cars
BP bus cycle	Test cycle developed by BP	England	Bus
TNO bus	Test cycle developed by TNO	Netherland	Bus
FHB motorcycle cycles	Test cycles developed by Biel University of applied science	Switzerland	Motorcycle

This material is reserved for educational use only, not allowed for commercial use.

Forbidden to modify the content, and cite the document when use.

The characteristics of driving cycle are different depending on the traffic, area, and vehicle types. The examples of value for the distance, duration, and average speed of each cycle are also provided in Table 2.2.

Table 2.2 Example of standard driving cycles

Legislative Cycles	Driving cycle name	Distance (m)	Duration (s)	Average Speed (km/h)
EU	ECE15	995	195	18.4
	Extra Urban Driving Cycle (EUDC)	6,955	400	62.6
	New European Driving Cycle (NEDC)	11,017	1,180	33.6
US	New York Bus Cycle	996	600	6.0
	Manhattan Bus Cycle	3,333	1,089	11.0
	Orange Country Bus Cycle	10,530	1,909	19.9
	EPA Highway Fuel Economy Test	16,503	765	77.7
Japan	JP 10 Mode	663	135	17.7
	Japanese New Transient Mode	1,387	1,829	27.4

2.1.3 The Use of Driving Cycle

Driving cycles have a wide range of applications in both transportation and automotive field. Driving cycles can represent the operating conditions from a certain region or a certain vehicle type. It is an important index for emission measurement and a basic information for vehicle design. Furthermore, it can also serve as an important simulation input to improve the performance of in-use vehicles. Designing driving cycles is the abstraction and sublimation of a large amount of driving data. Although there are many methods for designing driving cycles, the cognition about its essential characteristic is not very clear (Shi et al., 2016). Many studies around the world (S. Tamasnya, S. Chungpaibulpatana, 2009; Zhu, Shi, & Zhou, 2011), suggested that the driving cycle could be used for estimating the emission and analysing fuel consumption for vehicles. A study by Brady & O'Mahony (2016) also mentioned that pollutant emission and energy economy depend on vehicle characteristics, and actual driving data. In China, energy management strategy (EMS) for a plug-in hybrid electric vehicle (PHEV) were optimized by driving cycle model and dynamic programming (DP) algorithm (Fu, Wang, Cui, & Zhang, 2014).

The relationships between the energy consumption and vehicle velocity, acceleration, and roadway gradient were analysed (De Cauwer, Van Mierlo, & Coosemans, 2015; Wu, Freese, Cabrera, & Kitch, 2015). Energy consumption, vehicle scheduling, grid load profiles, and battery capacity were analysed by using existing bus network in the

This material is reserved for educational use only, not allowed for commercial use.

Forbidden to modify the content, and cite the document when use.

German city of Muenster regarding its electrification potential with fast charging battery buses (Rogge, Wollny, & Sauer, 2015). Table 2.3 presents a summary of real world driving cycles studies, including location, study objective, and data collection that were used in the driving cycle development.

Table 2.3 Summary of studies of real world driving cycles in the literatures.

Source	Objective	Programs	Vehicle	Real world driving pattern
Fu, X., Wang, H., Cui, N., & Zhang, C. (2014). Energy management strategy based on the driving cycle model for plugin hybrid electric vehicles. <i>Abstract and Applied Analysis</i> , 2014.	To calculate fuel consumption, EMS and SOC	DP Program And ADVISOR	School Bus	The central campus and QianFoshanz campus,
Brady, J., & O'Mahony, M. (2016). Development of a driving cycle to evaluate the energy economy of electric vehicles in urban areas. <i>Applied Energy</i> , 177, 165–178.	To develop a driving cycle to evaluate energy economy of electric vehicles. Improves on existing driving cycles by using real world data from electric vehicles.	Autonomies, simulation (ANL)	Seven Mitsubishi iMiEV BEV	Dubling city driving cycle
Wu, X., Freese, D., Cabrera, A., & Kitch, W. A. (2015). Electric Vehicles' Energy Consumption Measurement and Estimation. 2014 <i>Transportation Research Part D: Transport and Environment</i> , 34, 52–67.	To estimate energy consumption by using EV power estimation model		Nissan21pick up 20HP, 120v AC motor EV conversion	Freeway routes, California
De Cauwer, C., Van Mierlo, J., & Coosemans, T. (2015). Energy consumption prediction for electric vehicles based on real-world data. <i>Energies</i> , 8(8), 8573–8593.	To detect and quantify correlations between the kinematic parameters of the vehicle energy consumption		Nissan Leaf	Brussels City
S. Tamasnya, S. Chungpaibulpatana, B. L. (2009). Development of a driving cycle for the measurement of fuel consumption and exhaust emissions of automobiles in Bangkok during peak periods. <i>International Journal of Automotive Technology</i>	To develop a driving cycle for the measurement of fuel consumption and exhaust emissions		Toyota Corona 1.6L gasoline manual transmission	Bangkok Cycle

This material is reserved for educational use only, not allowed for commercial use.

Forbidden to modify the content, and cite the document when use.

Source	Objective	Programs	Vehicle	Real world driving pattern
Zhu, J., Shi, Q., & Zhou, J. (2011). The city bus driving cycle construction. In 2011	To construct a driving cycle based on actual bus speed for inspecting vehicle emission.		Bus	Typical bus lines of Hefei
Rogge, M., Wollny, S., & Sauer, D. U. (2015). Fast charging battery buses for the electrification of urban public transport-A feasibility study focusing on charging infrastructure and energy storage requirements. <i>Energies</i> , 8(5), 4587–4606.	To analyse how and to what extent existing bus networks can be electrified with fast charging battery buses.		Bus 18m.	German city of Muenster

2.1.4 Route Selection

The representative routes were identified by objective of developer which is necessary to reflect the traffic in the interested area such as urban, rural areas, inter-city, city, and so on. Due to the different traffic characteristics of each country, a route selection is the first step of driving cycle development. For example, Urban, sub-urban, and highway roads were identified as selected routes in Hong Kong based on the traffic density and the most frequently used route as referenced from Annual Average Daily Traffic (AADT) (Hung, Tong, Lee, Ha, & Pao, 2007). Traffic flow model was also used for selecting the major roads in city and confirmed by statistical parameters (variance and mean) that cover all driving speed patterns in city (S. Tamasnya, S. Chungpaibulpatana, 2009). For Sydney, driving cycle routes were selected according to road classification and the traffic density in areas reported with the highest emissions. Then, the driving patterns were measured in these regions and sample size for data collection was determined by conducting an OD survey (Galgamuwa, Perera, & Bandara, 2015).

2.1.5 Driving Data Collection Techniques

Although, there are several data collection methods from actual driving pattern. GPS is a widely used technique for driving cycle development. For instance, a driving cycle developed for Hong Kong in 2007, driving data were collected using an on board measurement method combined with a chase car method using GPS loggers (Hung et al., 2007). In India, a study by Nesamani & Subramanian (2011), characteristics of intra-city buses operating in Chennai were examined by using Global Positioning

This material is reserved for educational use only, not allowed for commercial use.

Forbidden to modify the content, and cite the document when use.

System (GPS) for intra-city buses driving cycle. Wu et al. (2015) used GPS in a smartphone to collect vehicle location data and to generate trip trajectories. Besides, a data collection system has been developed to collect in-use EV data and vehicles' driving information, not only GPS technique for collecting driving pattern. Another one of the driving cycles developed for Hong Kong (China) in 1999, data acquisition was done using optical sensor pointing to the axle of the vehicle while the speed data were collected into a s micro-computer (Galgamuwa et al., 2015).

2.1.6 Data Segmentation

Microtrip is a small portion of driving data that can be separated by periods of idle or could be defined as a segment of the cycle where the speed is non-zero (Feroldi & Carignano, 2016). The sequences of driving data between successive stops in the trip defined by S. Tamasnya, S. Chungpaibulpatana (2009). International urban driving cycle for light duty vehicles such as HK, FTP, NYCC, LA, Japanese 10-15 mode, etc. also use a microtrip in driving cycle construction method (Hung et al., 2007). A real-world specific driving cycle is developed from microtrip, which can represent actual traffic conditions and various operated vehicle speed ranges. Average speed of microtrip could be assigned to group the microtrips together for use as a database for driving cycle construction method (Galgamuwa et al., 2015).

2.1.7 Methodologies of Driving Cycle Construction

A practical methodology for constructing a representative driving cycle must reflects the real-world driving conditions, however there are several methodologies of driving cycle construction depending on the purpose of applying and the organization. The methods of driving cycle construction are summarized in Table 2.4.

Table 2.4 The driving cycle construction methods.

Method	City	Country
Maximums and Minimums	Hefei	China
	Manila	Philippines
Means and Averages	Hefei	China
	Hanoi	Vietnam
	Bangkok	Thailand
	Manila	Philippines
Standard Deviations and Percentiles	Hefei	China
	LA01	USA

This material is reserved for educational use only, not allowed for commercial use.

Forbidden to modify the content, and cite the document when use.

Method	City	Country
Percentages	Bangkok	Thailand
	Manila	Philippines
	Hefei	China
	Hanoi	Vietnam
	Pune	India
	Hong Kong	China
	Bangkok	Thailand
	Chennai	India
Specific Parameters	Hefei	China
	LA01	USA
	Hanoi	Vietnam
	Hong Kong	China
	Hefei	China
	Hanoi	Vietnam
	Sydney	Australia
	Istanbul	Turkey

2.2 Electric Vehicle Energy Consumption

Electric Vehicles are expected to gain a significant market share in the near future. Extensive studies performed by the University of California, Berkeley predict that approximately 2.5 million EVs will be on American roads by 2020 (Fiori, Ahn, & Rakha, 2016). In worldwide, commercial electric city bus prototype are forced by the government policies. In India, State government owned buses provides public road transportation services, the modal share of buses ranges from 5 to 40 percent in urban cities (Nesamani & Subramanian, 2011) In Thailand, 3,000 electric city buses are required in 2021 (Thai Electric Vehicle Co., 2016). The real driving data is necessary to estimate the energy consumption for the best electric vehicle efficiency.

2.2.1 Energy Consumption Measurement

Energy consumption is a significant parameter to obtain the best performance in electric vehicle design. In 2012, Gis, Zoltowski, & Bochenska studied of energy consumption of electric passenger car in both approval tests: European –NEDC and American – FTP. The measuring system enables the evaluation of the energy flow to and from battery, so the results of the dyno-tests represent the value of the energy taken from battery. Electrical power measuring and recording device in the study is shown in Figure 2.3.



Figure 2.3 Electrical power measuring and recording device

Source: Gis, W., Zoltowski, A., & Bochenska, A. (2012). Testing of the electric vehicle in driving cycles. *KONES Powertrain and Transport*, 19(4), 207–221.

2.2.2 Simulation by using Matlab

In a study by Draoui B, (2014), the influence of the electric air-conditioning system on the power consumption of a Lithium-ion battery was studied by using MATLAB Simulink. It was adopted to construct a hydraulic hybrid vehicle (HHV) and hybrid electric vehicle (HEV) complete models for backward simulations.

The New European Driving Cycles (NEDC) were used to determine the changes in fuel economy. The fuel economy, power component, and SOC level of the HEV and HHV were obtained through the NEDC simulation. In the MT vehicle performance analysis, UDC and EUDC had fuel consumptions of 8.88 and 6.59 L/100 km (average, 7.42 L/100 km), respectively (Chen, 2015).

2.3 Energy Storage Unit

Many research efforts are under way to develop and commercialize advanced batteries. The researchers seek to increase the energy and power capability, extend the life, and reduce costs of batteries as they are manufactured to sizes suitable to electric vehicles (Vancouver, 2017). Sizing battery methodology is based on the power requirements, including sustained speed tests and stochastic driving cycles. The sizing algorithm explicitly accounts for the Equivalent Consumption Minimization Strategy (ECMS). The simulation results highlight the importance of integrating sizing and energy management into fuel cell hybrid vehicles (Feroldi & Carignano, 2016). The estimating energy consumption of electric vehicles based on travel survey data, collected from conventional gasoline vehicles by GPS, was applied to study the impact of public

This material is reserved for educational use only, not allowed for commercial use.

Forbidden to modify the content, and cite the document when use.

charging infrastructure. An activity-based assessment method was proposed to evaluate electric vehicle feasibility for the heterogeneous traveling population in the real world driving context (Dong, Liu, & Lin, 2014).

2.3.1 Battery

Battery storage system for xEV is a storage device which converts the stored chemical energy into electrical energy. There are several characteristics that should be taken into account for selecting the most appropriate battery for EV (Tie & Tan, 2013). The design of battery system depends on the use purpose of the electric vehicle built. The installed energy of battery pack is a significant factor for suitable electric vehicle. Most current electric vehicles have been designed related to discharge pattern. There are several battery technologies available in the market as shown in Table 2.5.

Table 2.5 The comparison of different batteries types (Tie & Tan, 2013)

Energy storage Type	Specific energy (Wh/kg)	Energy density (Wh/L)	Specific power (W/kg)	Energy efficiency (%)
Lead acid battery				
Lead acid	35	100	180	>80
Advance lead acid	45	-	250	-
VRLA	50	-	150+	-
Metal foil lead acid	30	-	900	-
Lithium battery				
Lithium-iron sulphide (FeS)	150	-	300	80
Lithium-iron phosphate (LiFePO ₄)	120	220	2000-4500	-
Lithium-ion polymer (LiPo)	130-225	200-250	260-450	-
Lithium-ion	118-250	200-400	200-430	>95
Lithium-tatanate(LiTiO/NiMnO ₂)	80-100	-	4000	-
Nickel battery				
Nickel-iron	50-60	60	100-150	75
Nickel-zinc	75	140	170-260	76

This material is reserved for educational use only, not allowed for commercial use.

Forbidden to modify the content, and cite the document when use.

Energy storage Type	Specific energy (Wh/kg)	Energy density (Wh/L)	Specific power (W/kg)	Energy efficiency (%)
Nickel-cadmium (Ni-Cd)	50-80	300	200	75
Nickel-metal hydride (Ni-MH)	70-95	180-220	200-300	70
ZEBRA battery				
Sodium-sulphur	150-240	-	150-230	80
Sodium-nickel chloride	90-120	160	155	80

Improved versions of today's lead-acid batteries dominated through the late 1990s, because they were relatively inexpensive and reliable. In Europe, the nickel-cadmium battery and the high-temperature (250–320°C) sodium-nickel-chloride battery were also being used initially. Beyond lead-acid batteries, there is no consensus as to which batteries will prove superior for electric vehicles, though it is widely believed that nickel-metal hydride (NiMH) batteries will predominate over much of the next decade, and lithium-based batteries will dominate thereafter (Vancouver, 2017).

2.3.2 Ultracapacitor (UC)

Ultracapacitor (UC) or supercapacitor has a structure like normal capacitor, but higher capacitance than capacitor (high energy capacity with factor of 20 times). Its characteristic includes longer operating cycle life and insensitive to environment temperature variation. Currently, there are three types of UC technologies used in HEV and AEV; electric double-layer capacitors (EDLC)—carbon/carbon, pseudo-capacitors and hybrid capacitors. The difference between these UC is in their energy storage mechanisms and their electrode materials used. The specific power density for these three types UC is almost similar around 1000–2000 kW/kg for 95% efficient pulse but EDLC has a higher power density than other types of UC. Specific energy density of EDLC is the lowest (5–7 Wh/kg). However, the other two have almost similar energy density (10–15 Wh/kg). The UC lifetime can reach 40 years, which is the longest among all ESS (Tie & Tan, 2013).

2.3.3 Flywheels

Flywheel energy storage or FES is a storage device which stores/maintains kinetic energy through a rotor/flywheel rotation. A typical flywheel system uses a small motor

This material is reserved for educational use only, not allowed for commercial use.

Forbidden to modify the content, and cite the document when use.

to be rotating the wheel. After the fly wheel gains momentum, it spins freely on its own up to 100000 rpm. Flywheel technology has two approaches, i.e. kinetic energy (rotational energy) as output and electric energy as output energy. A typical car will require several flywheels to be comparable in range and performance to today's gasoline-powered car (Vancouver, 2017). With the development of flywheel technology, it is currently be widely used in various industry fields. The results of the study indicate that flywheel energy storage system is quite suitable for hybrid electric vehicle and with fuzzy logic control strategy both the performance of ICE and ISG are optimized that reduces fuel consumption of vehicle to greater extent (He, Ao, Guo, Chen, & Yang, 2009).

2.3.4 Hydrogen Energy

Hydrogen vehicle is the vehicle that uses hydrogen as an onboard energy to power the vehicle. The chemical energy (hydrogen gas) will convert into mechanical energy either by burning hydrogen in an ICE or by reacting hydrogen with oxygen in an FC to produce electricity. Hydrogen contains abundant energy per unit of weight but behave little energy per unit of volume, which is a major drawback for transportation (Tie & Tan, 2013) .

This research studied the energy consumption based on real-world driving cycle of university tram and buses using backward simulation in MATLAB/Simulink. Different driving pattern of three routes (closed-area, inter-city, and city) were collected. The electric energy consumption was calculated based on the vehicle dynamics equations.

CHAPTER 3

RESEARCH METHODOLOGY

3.1 Operation Routes

The routes surveyed in this study can be separated into 3 main types, closed-area routes operated by trams, inter-city routes operated by shuttle buses, and city routes operated by shuttle buses. These three different routes mainly differed operating in the distance i.e. about 3-6 km, 16-25 km, 9-16 km, and 9-16 km for closed-area, inter-city, and city route, respectively. The total distance of collected data in this study was 5,333.65 km.

3.1.1 Closed-Area Route Operated by Tram

Four different tram routes investigated in this study are displayed in Figure 3.1. The total number of cycle and driving distance of tram collected for this study were 124 cycles and 516.40 km, respectively, as shown in Table 3.1.

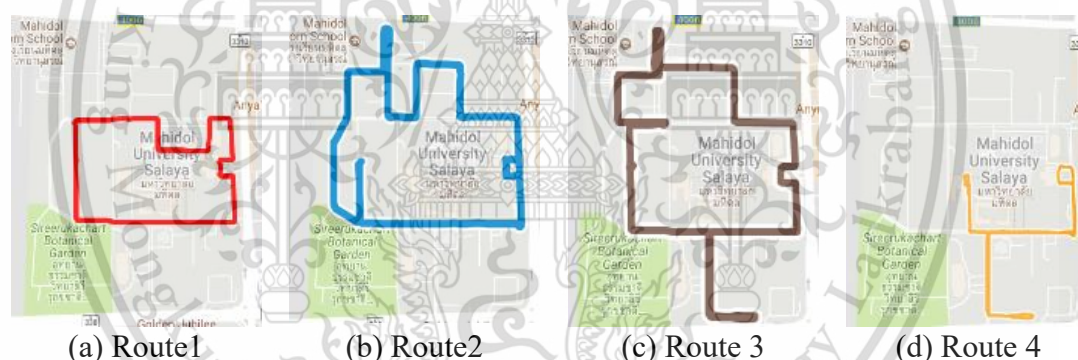

Figure 3.1 Closed-area routes operated by trams

Table 3.1 Data collected in closed-area routes operated by trams

Tram Route	1	2	3	4	Total
Number of Cycle	30	31	32	31	124
Distance (km)	91.54	147.78	166.72	110.36	516.40

3.1.2 City route operated by shuttle bus

The city routes are shown in Table 3.2. The total number of cycle and driving distance of shuttle bus collected for this study were 39 cycles and 266.41 km, respectively, as shown in the Table 3.2.

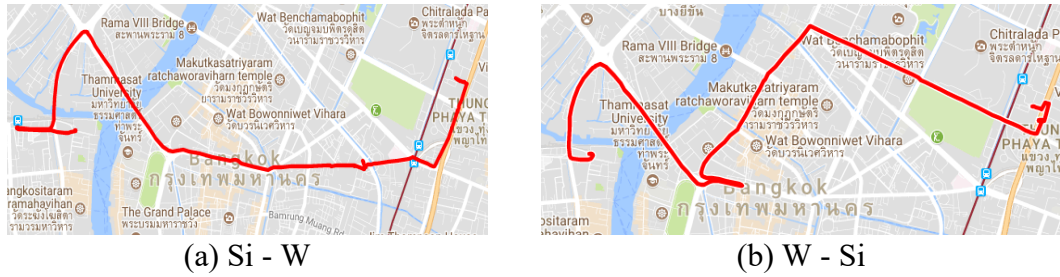

Figure 3.2 City routes operated by shuttle buses

Table 3.2 Data collected in city routes operated by shuttle bus routes

Shuttle Bus Route	Si - W	W - Si	Total
Number of Cycle	20	19	39
Distance (km)	132.33	134.08	266.41

3.1.3 Inter-City route Operated by Shuttle Bus and Salaya Link Bus

There are two vehicle types of inter-city route; the shuttle bus and Salaya Link bus as shown in Figure 3.3 and Figure 3.4, respectively. The total number of cycle and driving distance of shuttle bus collected for this study were 130 cycles and 3,067.15 km, Salaya Link were 37 cycles, and 1,483.69 km as shown in the Table 3.3-Table 3.4. The total collected distance for inter-city route is 4,550.84 km.

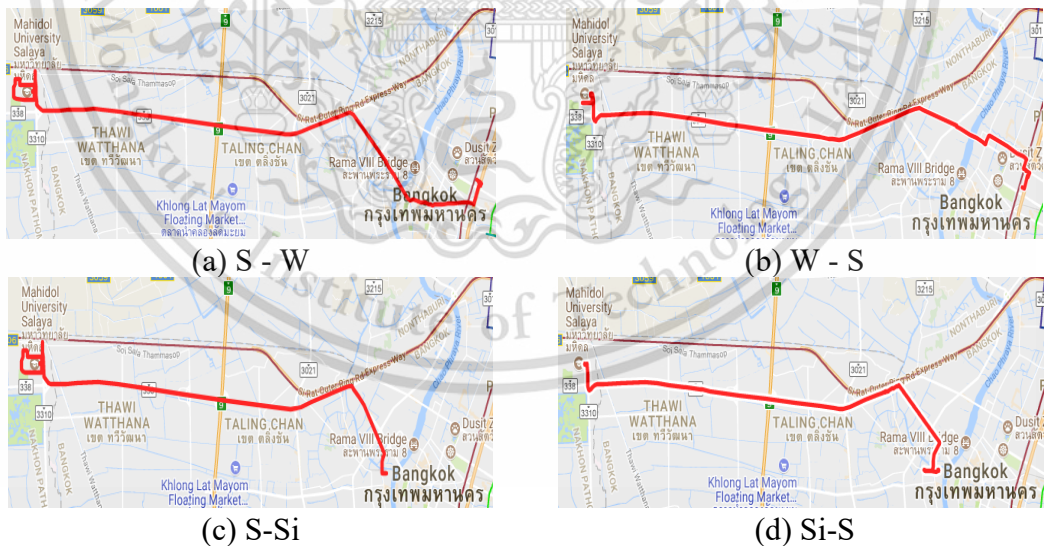

Figure 3.3 Inter-city routes operated by shuttle buses

Table 3.3 Data collected in inter-city routes operated by shuttle buses

Shuttle Bus Route	S - W	W - S	S - Si	Si - S	Total
Number of Cycle	45	47	20	18	130
Distance (km)	1,181.45	1,159.94	422.01	303.75	3,067.15

This material is reserved for educational use only, not allowed for commercial use.

Forbidden to modify the content, and cite the document when use.

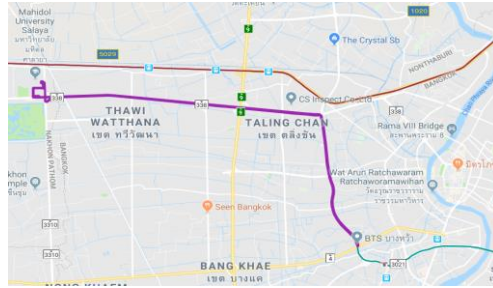

Figure 3.4 Inter-city routes operated by Salaya Link buses

Table 3.4 Data collected in inter-city routes operated by Salaya Link buses

Salaya Link Bus Route	Salaya - Bang Wa - Salaya
Number of Cycle	37
Distance (km)	1,483.69

3.2 Data Collection

The analysis was based on a real-world operating data collection through a GPS-based equipment, V Box (VB20SL3, Racelogic Ltd). The calculated energy consumptions were compared between three different types of applications i.e. a closed-area (tram), inter-city (shuttle bus, Salaya link), and city (shuttle bus). Driving data were collected from service vehicles that were in operation between 7:00 a.m. to 18:00 p.m. from Monday to Friday to represent a range of weekday service driving pattern. An investigation was conducted during July 2017 to February 2018. The details of data collection setup are shown in Table 3.5.

Table 3.5 Data collection setup details

Type of route	Closed-Area	Inter-City	City
Vehicles Configuration	Tram 	Shuttle Bus/Salaya Link 	Shuttle Bus 
Number of seats	29	35	35
Measurement Equipment		V Box (VB20SL3, Racelogic Ltd.)	
Acquired Data	Speed, Latitude, Longitude, Time,		

3.3 Driving Cycle Development

Driving cycle is a series of data points representing the speed of vehicle versus time and is developed for certain road, route, specific area, or city. It is widely used in many applications for vehicle manufacturers, environmentalists, and traffic engineers. In this study, the relation of driving cycle and energy consumption was a subject of interest for designing an energy storage for an electric bus. First, the driving data of tram, shuttle bus, and Salaya Link were collected. The surveyed closed-area route, inter-city route, and city route had many operating parameters e.g. time per cycle, number of passengers, and travel distance, etc. Collected data was simulated in order to generate the driving cycle pattern. The result of energy consumption based on these different parameters would be important for the suitable design purpose. Overview of driving cycle development process and their parameter are presented in Figure 3.5. T_{limit} , T_{range} , and T_{gen} were the important parameters obtained from collected driving data, microtrip data segmentation, and generated driving cycle, respectively. Furthermore, in a microtrip data segmentation step, there were two methods considered in this study i.e. number of microtrips method (NM) and time spent method (TM). The description of the parameters is explained in section 3.3.

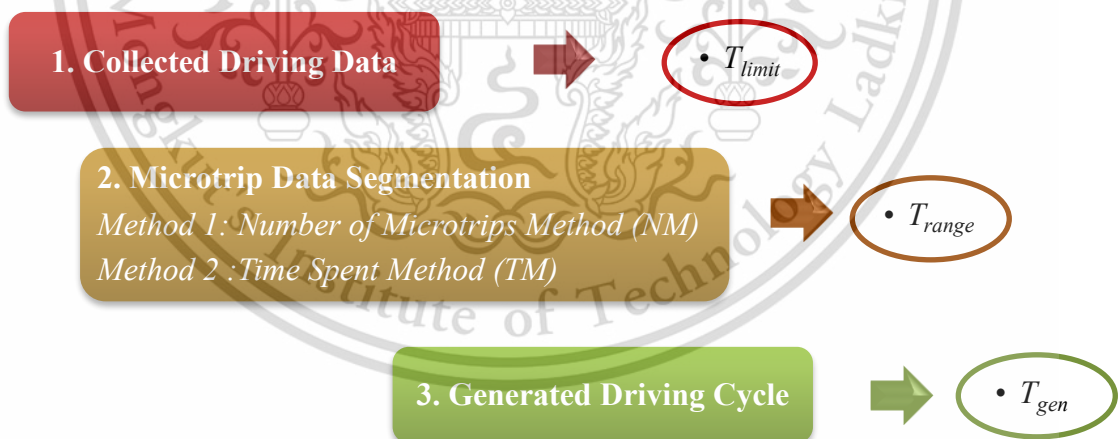

Figure 3.5 Driving cycle development process

3.3.1 Collected Driving Data Characteristics

In order to distinguish between each service route, the operating characteristics of each route type were represented by the value of average velocity standard deviation (V_{sd}),

This material is reserved for educational use only, not allowed for commercial use.

Forbidden to modify the content, and cite the document when use.

average speed (V_{avg}), maximum velocity (V_{max}), and average time per one cycle. The operating characteristics from closed-area, inter-city, and city of different service routes are shown in Table 3.6-Table 3.8, respectively. Each value was obtained by averaging the relevant values from each individual cycle collected for each service route. In the following section, the averaged time per cycle (T_{limit}) was then used as a main constraint for a driving cycle development for each service route. T_{limit} of each service route is different depended on operated area.

Table 3.6 Closed-area operating characteristics per cycle for each route

Route	Velocity (km/h)			T_{limit} (h:mm:ss)	Passengers (person)	
	V_{sd}	V_{avg}	V_{max}		Mean	Max
1	1.616	15.620	58.630	0:13:22	5	34
2	1.242	17.732	41.483	0:19:49	9	30
3	2.163	16.258	40.135	0:21:15	13	48
4	1.253	15.098	36.744	0:14:55	6	44

Table 3.7 Inter-city operating characteristics per cycle for each route

Route	Velocity (km/h)			T_{limit} (h:mm:ss)	Passengers (person)	
	V_{sd}	V_{avg}	V_{max}		Mean	Max
S-Wit	5.80	26.27	85.44	1:01:15	27	63
Wit-S	4.90	24.85	93.78	1:01:06		
S-Si	4.05	31.99	86.90	0:39:18		
Si-S	3.49	19.30	84.26	0:52:03	22	44
Salaya Link	6.76	32.06	101.46	1:21:55		

Table 3.8 City operating characteristics per cycle for each route

Route	Velocity (km/h)			T_{limit} (h:mm:ss)	Passengers (person)	
	V_{sd}	V_{avg}	V_{max}		Mean	Max
Si-Wit	2.04	13.80	67.06	0:39:06	27	63
Wit-Si	2.79	9.79	60.56	0:49:17		

3.3.2 Microtrip Data Segmentation

Driving patterns of each route type have different characteristics. The speed-time data obtained from real-world trams operating in the university were divided into small parts of driving data i.e. Microtrips. Microtrip is a small portion of driving data that could be separated by periods of idle. The segmentation process was carried out on all collected cycles to form a database of microtrips for each service route. These databases were

This material is reserved for educational use only, not allowed for commercial use.

Forbidden to modify the content, and cite the document when use.

then used in a randomly selection process of microtrips in order to construct a driving cycle representative for each route. The velocity ranges of microtrips were categorized by a range of their corresponding averaged velocity. Three different route types have different speed ranges, which are 0-40 km/h, 0-85 km/h, and 0-70 km/h for closed-area, inter-city, and city respectively. The process details for the driving data separation into microtrips can be described as in Figure 3.6. Additionally, the example of microtrips segmentation is illustrated in Figure 3.7.

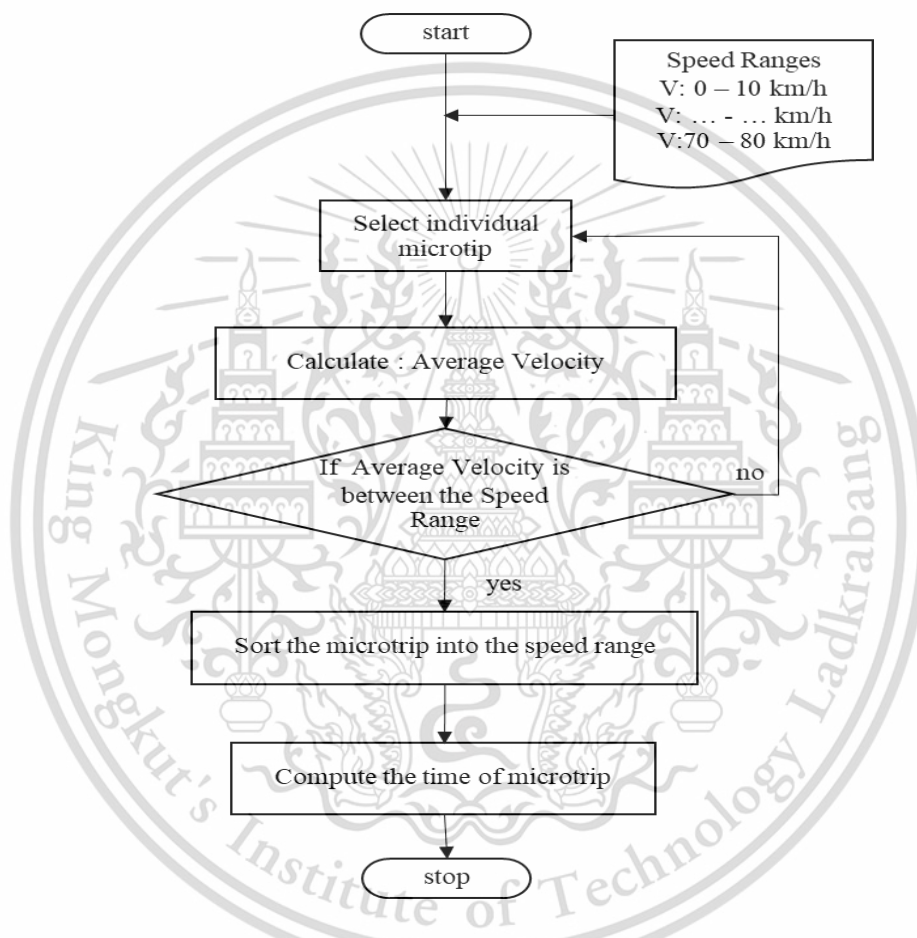

Figure 3.6 Microtrip Separation Process

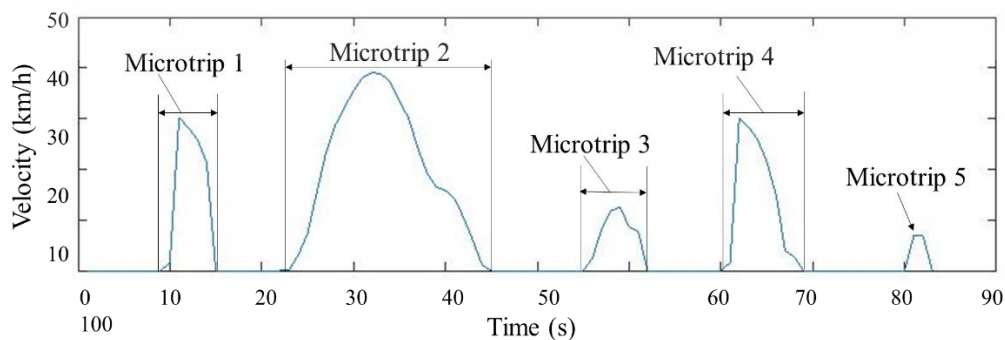

Figure 3.7 Example of microtrips segmentation from a speed-time data

This material is reserved for educational use only, not allowed for commercial use.

Forbidden to modify the content, and cite the document when use.

In this study, there were two different methods used in a microtrip data segmentation which was number of microtrips method (NM) and time spent method (TM). Based on average speeds of microtrip, proportions under different speed intervals were calculated to percentage (N) for number of microtrips method (NM), as well as the time spent percentage in each speed interval was determined (T) for time spent method (TM). The percentage proportion of number of microtrip (N) and time spent (T) were then used for a calculation of speed range limit time (T_{range}) by multiplying each value with the collected average time per cycle (T_{limit}).

a) Number of Microtrips Method (NM)

Based on the average speeds of each microtrip, the microtrips were classified and grouped into different speed range at an interval of 10 km/h. The speed range limit time (T_{range}), which time value used in generating representative driving cycles as a duration of time limit allowed for each speed range, was calculated as equation (3.1).

$$T_{range} = N \times T_{limit} \quad (3.1)$$

where

- T_{range} = Speed range limit time (s)
- N = Number of microtrip in each speed range (%)
- T_{limit} = The averaged time per cycle (s)

b) Time Spent Method (TM)

Percentage of time spent in microtrips under various average speed ranges obtained from the total collected data time. T_{range} of time spent method was calculated as equation (3.2).

$$T_{range} = T \times T_{limit} \quad (3.2)$$

where

- T_{range} = Speed range limit time (s)
- T = Time spent by microtrip in each speed ranges (%)
- T_{limit} = The averaged time per cycle (s)

3.3.3 Driving Cycle Construction

Each route of service trams surveyed in this study had a certain operating pattern because of the nature of their operations i.e. bus stops and certain type of road features. This material is reserved for educational use only, not allowed for commercial use.

Forbidden to modify the content, and cite the document when use.

which made the vehicles stopped such as T-junction, washboard road, pedestrian crossing, etc. While, shuttle bus operating pattern fixed the bus stop, but it had the different characteristic depend on the traffic. As a result, the influence of the driver behaviour's on collected driving data was minimum. In this study, driving cycles were constructed by using speed range limit time (T_{range}), as calculated in section 3.3.2, for main criterion constructed driving cycle. The error for time, distance, and idle of each speed range must be within 15%, 20%, and 2%, respectively. Furthermore, the driving cycle pattern was constructed sequentially according to the speed ranges as explained in an earlier section. The procedure of driving cycle construction is shown graphically in Figure 3.8.

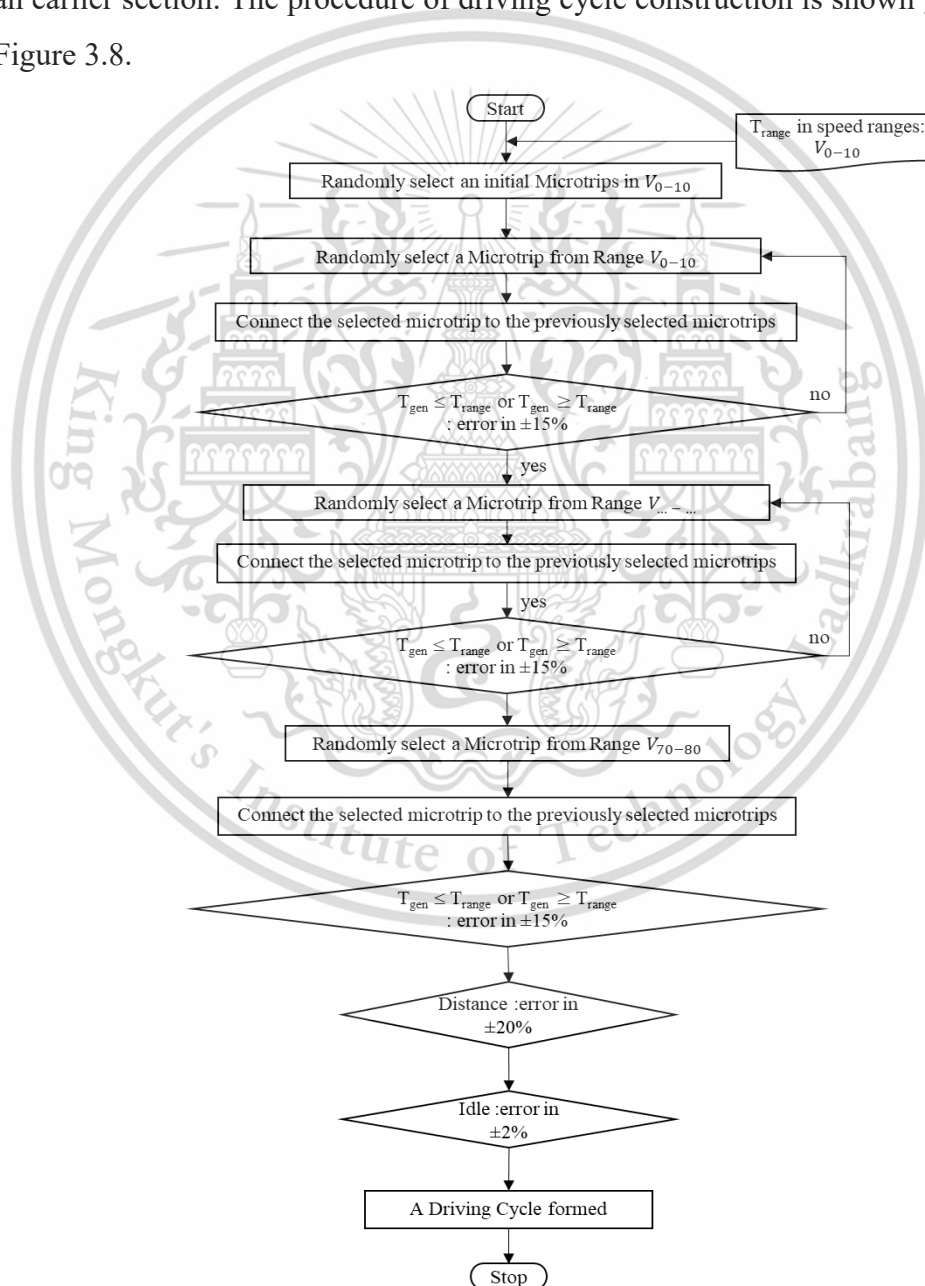

Figure 3.8 Driving cycle construction procedure flow chart

This material is prepared for educational use only, not allowed for commercial use.

Forbidden to modify the content, and cite the document when use.

3.3.4 Generated Driving Cycle

In the previous section, a driving cycle in each service route was formed by a random selection of microtrips from all collected driving data. The example of generated driving cycle is illustrated in Figure 3.9. In this study, ten candidates of such driving cycles were generated for each route. The percentage of the error between, T_{range} , distance, and idle in each speed ranges were considered in order to select the best representative driving cycle. Sum of error resulting time in generated driving cycle could be accepted at 15%.

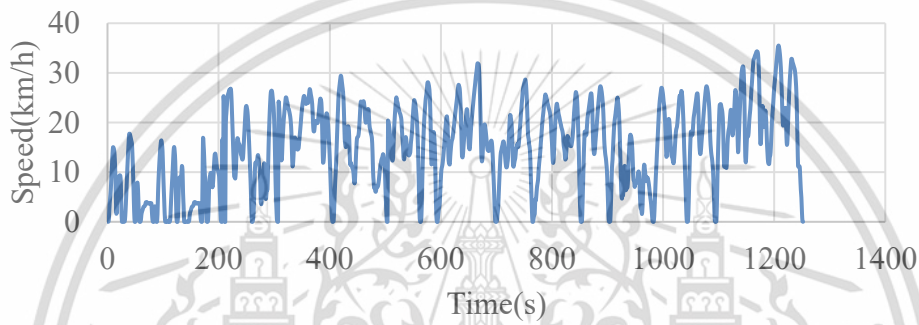

Figure 3.9 The example of generated of driving cycle.

The generated driving cycle were investigated to calculate the errors between T_{gen} and T_{range} . The weight factor was also considered in the calculating as well. The weight factor assigned to each sum of the errors were depended on which kind of driving parameters is desired to have a greater contribution to the developed cycle. The weight factor defined by the percentage of number of microtrips and the percentage of time spent for NM method and TM method, respectively. The resulting error from each speed range, i.e. E_1, E_2, \dots, E_8 were the function of discrepancy between T_{gen} and T_{range} including weight factor by microtrip data segmentation method i.e. NM method and TM method for each speed range presented in the database. The equation of the errors calculation in each speed ranges are given by;

$$E_n = \left| \frac{T_{range} - T_{gen}}{T_{range}} \right| \times W_{a-b_n} \times 100 (\%) \quad (3.3)$$

where E_n = The error of the speed range n -th, $n=1, 2, \dots, 8$
 W_{a-b} = Weight factor for each speed range 0 – 10 km/h, ..., and 70-80 km/h, respectively.

This material is reserved for educational use only, not allowed for commercial use.

Forbidden to modify the content, and cite the document when use.

In other word, the contributions to the total error (E) were due to the percentage of number of microtrip in each speed range for each route. Finally, the sum of error including weight factor was determined as followed:

$$E = \sum_{n=1}^8 E_n = E_1 + E_2 + E_3 + E_4 + E_5 + E_6 + E_7 + E_8 \quad (3.4)$$

where E = The total error (%)

3.4 Energy Consumption Calculation

3.4.1 Traction Energy Consumption Calculation

The energy consumption was calculated from a fundamental theory of vehicle dynamics. In this study, the electric power was assumed to be equal to the power required to produce a tractive force. The energy involving air conditioning, auxiliary system components, and regenerative brake were ignored in this section. The tractive force could be described by the following equation:

$$F = R_a + R_r + R_{cl} \quad (3.5)$$

where F = The tractive force (N),
 R_a = The aerodynamic resistance (N)
 R_r = The rolling resistance (N)
 R_{cl} = Grade resistant (N).

R_a , R_r , and R_{cl} were calculated when a tram was traveling at constant velocity,

$$R_a = C_d \frac{\rho}{2} A v^2 \quad (3.6)$$

$$R_r = f_r m g \cos\theta \quad (3.7)$$

$$R_{cl} = m g \sin\theta \quad (3.8)$$

$$F = C_d \frac{\rho}{2} A v^2 + f_r m g \cos\theta + m g \sin\theta \quad (3.9)$$

where v = Velocity (m/s²)
 C_d = Coefficient of drag
 ρ = Air density (kg/m³)
 A = Frontal area of the vehicle (m²)

This material is reserved for educational and research purposes. It is not to be used for commercial use.

Forbidden to modify the content, and cite the document when use.

f_r	=	Rolling resistance constant
g	=	Gravity acceleration ($g = 9.81 \text{ m/s}^2$)
m	=	A mass of vehicle (kg)
θ	=	The road grade (degree)
F	=	The tractive force (N)

Finally, the tractive force (F) was found in equation (3.9) by combining equation (3.6), equation (3.7), and equation (3.8). To calculate energy consumption, the power for vehicle traveling at velocity (v) was required. Required power, (P) (Watt), could be determined from the relationship between F and v in equation (3.10).

$$P = F \cdot v \quad (3.10)$$

where

P	=	Power (Watt)
F	=	The tractive force (N)
v	=	velocity (m/s^2)

In this study, the energy consumption was calculated by using geometric parameters of 9-meter EV bus prototype and other constants as shown in Table 3.9.

Table 3.9 Parameters for energy consumption calculation

General characteristics of Vehicle (Medium-sized Bus)	
Parameters	Value
Curb weight (kg)	9000
Vehicle frontal area (m^2)	7.5
Rolling Resistance	0.015
Drag coefficient	0.7
Air Density (kg/m^3)	0.114
Gravity Acceleration (m/s^2)	9.8

The values from Table 3.9 were used for calculating power in equation (3.10). The controlled variable was velocity. The closed-area, inter-city, and city routes driving cycles generated as described in the previous section were used as a calculation input for each service route. The traction energy consumption (E_t) was calculated as below.

$$E_t = P \times t \quad (3.11)$$

where

E_t	=	Traction energy consumption (kWh)
P	=	Power (Watt)
t	=	Time (s)

This material is reserved for educational use only, not allowed for commercial use.

Forbidden to modify the content, and cite the document when use.

A vehicle weight was a sum of the curb weight and the averaged passenger weight recorded in each service tram route. MATLAB Simulink was used to calculate the energy consumption by using the workflow as described in Figure 3.10.

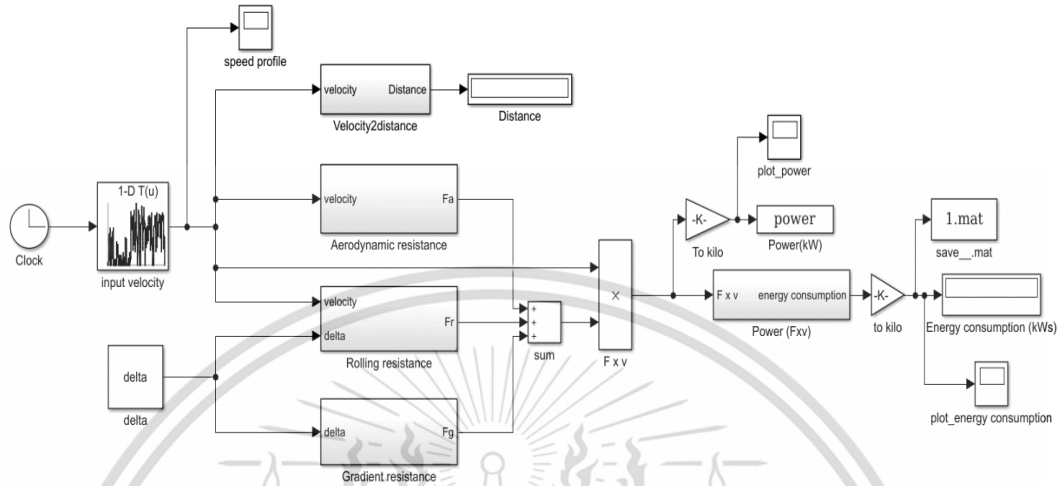

Figure 3.10 MATLAB Simulink for energy consumption calculation

The traction energy consumption in kWh/km ($E_{traction}$) was calculated as equation (3.12).

$$E_{Traction} = \frac{E_t}{D_{avg}} \quad (3.12)$$

where $E_{Traction}$ = Traction energy consumption rate (kWh/km)
 D_{avg} = Average distance per cycle (km)

3.4.2 Total Energy Consumption Calculation

The main EV components and auxiliary system could have a significant effort to the overall energy consumption of electric vehicles. Table 3.10 shown the parameters of EV components and auxiliary system for energy consumption calculation. Sum of the main EV components load is shown in Figure 3.11. The constant value of total load for main EV components and auxiliary system (P_c) used in this study was 14.26 kW.

Table 3.10 Parameters of main EV components and auxiliary system for energy consumption calculation

EV Components	Load (kW)
Pneumatic pump	2.20
Air Condition	10.00
DC Water Cooling Pump	0.06
Steering Pump and Controller	1.50
Accessory Load	0.50
Total Load	14.26

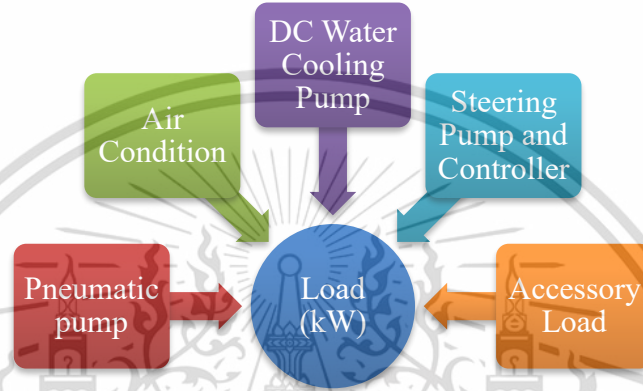

Figure 3.11 Main EV components and auxiliary system load

$$E_c = P_c \times \frac{T_{limit}}{3600} \quad (3.13)$$

where E_c = Energy consumption of main EV components and auxiliary system (kWh)
 P_c = Main EV components and auxiliary system load (kW)
 T_{limit} = Average time per cycle (s)

The total energy consumption (E_T) in kWh is sum of traction energy consumption based on driving cycle and energy consumption of main EV components and auxiliary system (E_c). The total energy consumption (E_T) in kWh is shown in equation (3.14).

$$E_T = E_t + E_c \quad (3.14)$$

where E_T = Total energy consumption (kWh)

The total energy consumption rate (E_{Total}) in kWh/km is the total energy consumption in kWh (E_T) divided by an average distance per cycle (D_{avg}). E_{Total} expressed as equation (3.15).

This material is reserved for educational use only, not allowed for commercial use.

Forbidden to modify the content, and cite the document when use.

$$E_{Total} = \frac{E_T}{D_{avg}} \quad (3.15)$$

where E_{Total} = Total energy consumption rate (kWh/km)
 D_{avg} = Average distance per cycle (km)

3.5 Battery Sizing

One of significant parameters in a battery sizing calculation was a total installed battery energy in watt-hours (Wh). This was used to calculate a suitable energy consumption of specific area and driving characteristic. The different types of routes would have different battery sizing concepts. In this study, two different approaches for battery sizing section i.e. campus bus operation and fixed vehicle range were considered. The first methodology; campus bus operation; tried to design electric bus according to current bus operation (ICE bus) and fixing charging station at terminal of each routes. For fixed vehicle range, we try to design the common bus for all routes. The three battery sizes were sensible; i.e. 100kWh, 150kWh, and 200kWh, in order to analyze the appropriate size of battery. The energy consumption rate in kWh/km, denoted as *maximum power*, $E_{Traction}$ and E_{Total} , calculated from real world driving cycle was used to calculate energy demand. Lithium-ion batteries are famous used in electric public transport buses due to sufficient performance and charging application (Rogge et al., 2015). Parameters of Lithium Iron Phosphate (LFP) which is one type of Lithium-ion battery were used in this study in order to determine the suitable battery sizes. The efficiency of LFP battery of 0.94 was used (Pihlatie et al., 2015). The usable energy form installed batteries ($E_{battery}$) of each battery size was calculated from equation (3.16).

$$E_{battery} = \eta \times Battery\ Size \quad (3.16)$$

where $E_{battery}$ = The usable energy form installed battery (kWh)
 η = Efficiency of LFP battery

3.5.1 Battery Sizing for Campus Bus Operation

The analysis was based on the real-world data of the campus bus network of the university in Thailand. In this study, the battery in sizing with related to operation distance per day and current operation pattern by fixing the charging station at terminal

This material is reserved for educational use only, not allowed for commercial use.

Forbidden to modify the content, and cite the document when use.

of each route. The typical real service trip of campus bus according to the set of identified service trips were described in Section 3.1. The timetable of campus bus, which could be found in APPENDIX E, APPENDIX F, and APPENDIX G was used for the bus scheduling to enable separate battery sizing analysis of each route type. In this study, every campus bus serves only one routes without any deadheading trips. After a service trip is finished, the bus waits at the terminal stop until the next service trip on the same route starts from the current stop. During the dwell time at the terminal stop, the bus has the possibility to share its batteries. The different battery size could be used for opportunity charging bussed depending on the localization of the charging stations according to the desired operating range and the demanded charging power. In this study, the number charger stations were assumed to be 1, 2, and 1 for closed-area, inter-city, and city routes, respectively. The inter-city route was assumed to have two charging stations because of long distance and terminal stops are in campus 1 and campus 2. On the other hand, closed-area and city routes operated less than 10 km, which implied the battery size should be enough to return to charge at the terminal stop of each route. The campus bus charging station location for each route are displayed in Figure 3.12.



Figure 3.12 Proposed location of campus bus charging station locations

The required energy for battery sizing calculated from the operation distance and number of driving service cycle per day of each route. N_{cycle} is the maximum number of driving service cycle of each route per day. D_{avg} is a maximum average distance of each route per day. Operation distance per day (D_{day}) was calculated as equation (3.17).

This material is reserved for educational use only, not allowed for commercial use.

Forbidden to modify the content, and cite the document when use.

$$D_{day} = N_{cycle} \times D_{avg} \quad (3.17)$$

where D_{day} = Operation distance per day (km)
 N_{cycle} = Number of operation cycles per day (cycles)

In this study, the energy required for battery sizing were separated into two cases i.e. battery sizing from traction consumption and total consumption. For sizing battery, traction energy consumption rate ($E_{Traction}$) in kWh/km and operation distance per day (D_{day}) were used to calculate battery sizing for each route as equation (3.18).

$$E_{required,t} = E_{Traction} \times D_{day} \quad (3.18)$$

where $E_{required,t}$ = Traction energy consumption for battery sizing (kWh)
 $E_{Traction}$ = Traction energy consumption rate (kWh/km)
 D_{day} = Operation distance per day (km)

For sizing battery, total energy consumption rate (E_{Total}) in kWh/km and operation distance per day (D_{day}) were used for battery sizing calculation of each route as equation (3.19).

$$E_{required,total} = E_{Total} \times D_{day} \quad (3.19)$$

where $E_{required,total}$ = Total energy consumption for battery sizing (kWh)
 E_{Total} = Total energy consumption rate (kWh/km)
 D_{day} = Operation distance per day (km)

The number of cycles for traction ($N_{Traction}$) and total driving (N_{Total}) were the number of cycles that campus bus could operate from available energy from the installed batteries. In case of the $E_{required,t}$ and $E_{required,total}$ in one day are more than the installed battery. $N_{Traction}$ and N_{Total} were calculated by using installed battery was calculated as equation (3.20) and equation (3.21) to estimate the optimisation of the timing and duration of recharging events.

$$N_{Traction} = \frac{E_{required,t}}{Battery\ size} \quad (3.20)$$

$$N_{Total} = \frac{E_{required,total}}{Battery\ size} \quad (3.21)$$

where $N_{Traction}$ = Number of traction cycles (cycles)
 N_{Total} = Number of total cycles (cycles)
Battery size = Overall energy from installed battery packs (kWh)

In this study, in case of the number of cycles for traction ($N_{Traction}$) or total driving (N_{Total}) were more than the number of operation cycles per day (N_{cycle}). This case would use the correct symbol (✓) to indicated that the energy from the installed batteries was enough to service all day after overnight charging. In the other hand, in case of N_{cycle} was more than or equal to the $N_{Traction}$ or N_{Total} , wrong symbol (✗) was used to indicated that energy from installed battery wasn't enough to operate all day. The number of cycles for traction ($N_{Traction}$) or total driving (N_{Total}) were the timing to charge at the terminal stops.

3.5.2 Battery Sizing Estimated Using a Fixed Vehicle Range Approach

In this section, charging station location and battery sizing of public buses were designed for the new routes which in different target distance. The length of operation bus routes was different depended on the service route types. In this study, the ranges of start and end location (D_{fix}) for service routes were assumed at 50km, 100km, 150km, and 200km. The installed batteries of public buses for closed-area, inter-city, and city routed were varied with in 100kWh, 150kWh, and 200kWh. First, the charging station locations for one trip were considered by the driving ranges of installed batteries. The available battery energy of each battery size ($E_{battery}$) was calculated as equation (3.16). In the calculation, every bus serves one route from start to end terminal. With charging power 90 kW as in Table 3.11, the dwell time was assumed enough for charging. Then, the effect of total performance of battery size were considered. Finally, a suitable battery size for closed-area, inter-city and city routes were chosen by installed battery and charging stations cost.

a) Charging Station Location

In this part, the charging infrastructure for one trip was assumed to be located depending on the vehicle range. The driving ranges under varied the battery sizes was calculated as equation (3.22).

$$D_{charger,t} = \frac{E_{battery}}{E_{Traction}} \quad (3.22)$$

$$D_{charger,total} = \frac{E_{battery}}{E_{Total}} \quad (3.23)$$

where $D_{charger,t}$ = The distance of located charging station for traction driving range (km)

$D_{charger,total}$ = The distance of located charging for total driving range (km)

b) Battery Sizing

The required energy for battery sizing of each route was calculated from the different fixed distance. There were two cases of energy required i.e. traction energy consumption and total energy consumption. For sizing battery, traction energy consumption rate ($E_{Traction}$) in kWh/km and the fixed operation distance (D_{fix}) were used to calculate battery sizing for each route as equation (3.24).

$$E_{required,t} = E_{Traction} \times D_{fix} \quad (3.24)$$

where $E_{required,t}$ = Traction energy consumption for battery sizing (kWh)

$E_{Traction}$ = Traction energy consumption rate (kWh/km)

D_{fix} = Fixed operation distance (km)

For sizing battery, total energy consumption rate (E_{Total}) in kWh/km and the fixed operation distance (D_{fix}) were used to calculate battery sizing for each route as equation (3.25).

$$E_{required,total} = E_{Total} \times D_{fix} \quad (3.25)$$

where $E_{required,total}$ = Traction energy consumption for battery sizing (kWh)

E_{Total} = Total energy consumption rate (kWh/km)

This material is reserved for educational use only, not allowed for commercial use.

Forbidden to modify the content, and cite the document when use.

Generally, the main cost of electric public buses is from battery price and charging stations. The approach of this study was to calculate a suitable investment price for driving characteristic of closed-area, inter-city, and city routes. Assuming every bus has a charger at the start terminal, the number of charging stations including the charger at start terminal ($N_{charger}$) required per bus that were installed under varied the battery size was calculated as equation (3.26) and equation (3.27).

$$N_{charger,t} = \frac{E_{required,t}}{E_{battery}} + 1 \quad (3.26)$$

$$N_{charger,total} = \frac{E_{required,total}}{E_{battery}} + 1 \quad (3.27)$$

where $N_{charger,t}$ = The number of chargers for traction driving range
 $N_{charger,total}$ = The number of chargers for total driving range

Remark: $N_{charger}$ was round down to an integer.

The cost of service and maintenance was neglected in this study. Campus buses of each route had the same general characteristics of vehicle (medium-sized bus) as given in Table 3.9. Table 3.11 shows the battery price of LFP (Lithium iron phosphate) and charger unit price.

Table 3.11 Battery price and charger unit price

	Type	Price	Sources
Battery Cost	LFP (Lithium iron phosphate)	600 €/kWh	23,295 THB/kWh (Pihlatie et al., 2015)
Charger Unit Price	Level 3 DC fast charger Charging circuit 50V, 200 A Power 90 kW	50,000 Us dollars	1,661,651 THB/unit (Dong et al., 2014)

Source: <https://th.valutafx.com/USD-THB.htm> Date: 6/07/2018

The cost of installed battery and charging station by varied the battery size were considered. The lowest investment cost of each route was chosen to be the representative case usage. The total cost for electric public bus were separated into two section i.e. investment cost for traction energy consumption ($Cost_{Traction}$) and investment cost for total energy consumption ($Cost_{Total}$). $Cost_{Traction}$ and $Cost_{Total}$ calculation, in THB, are shown in equation (3.28) and equation (3.28), respectively.

$$Cost_{Traction} = (Battery\ cost \times E_{required,t}) + (Charger\ unit\ price \times N_{charger,t}) \quad (3.28)$$

$$Cost_{Total} = (Battery\ cost \times E_{required,total}) + (Charger\ unit\ price \times N_{charger,total}) \quad (3.29)$$

This material is reserved for educational use only, not allowed for commercial use.

Forbidden to modify the content, and cite the document when use.

CHAPTER 4

RESULTS

4.1 Driving Cycle Development

As explained in CHAPTER 3, the collected driving data were separated into microtrips (Figure 3.6 and Figure 3.7) and were arranged into different speed ranges by the corresponding averaged velocity of each microtrip. The representative of collected driving characteristic of the closed-area (Route 4), inter-city (Salaya-Siriraj), and city (Siriraj-Wit) for service from GPS data are shown in Table 4.1.

Table 4.1 Collected driving characteristic of representative routes from GPS

Route	Closed-Area	Inter-City	City
V_{avg} (km/h)	13.13	25.54	9.16
V_{max} (km/h)	36.42	81.84	66.52
Distance (km)	3.679	21.101	6.616
Time(s)	895	2358	1797
Idle (s)	78	375	681

4.1.1 Percentage error of representative generated driving cycles

Closed-area, inter-city, and city showed significantly different characteristic. Closed-area speed range was 0 - 40 km/h, inter-city speed range was 0 - 90 km/h, and city speed range was 0 - 60 km/h. The resulting driving cycles were then constructed as explained in Figure 3.8. Ten candidates of generated driving cycle were chosen by the lowest sum of error which had taken into account the weight factor as explained in section 3.3.4. The percentage error of representative generated driving cycles was separated into two sections of two different methods in T_{range} calculation number of microtrips method (NM) and time spent method (TM).

- **Percentage error by using number of microtrips method (NM)**

The obtained values of sum of error (E) from number of microtrips method of closed-area and inter-city routes are depicted in Figure 4.1. The maximum error for time, distance and idle of closed-area operated by tram were 6.62%, 11.52%, and 6.06%. Meanwhile, the maximum error of time, distance and idle for inter-city routes operated by shuttle bus were 8.16%, 32.76%, and 79.68%, respectively.

This material is reserved for educational use only, not allowed for commercial use.

Forbidden to modify the content, and cite the document when use.

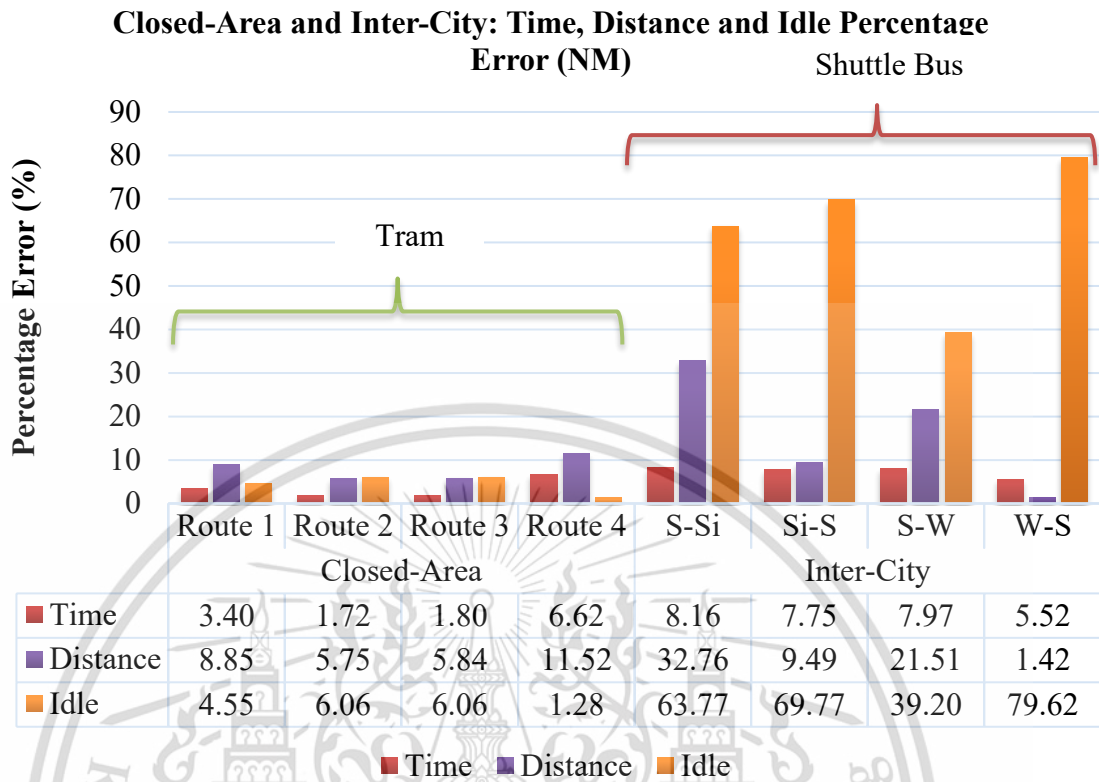

Figure 4.1 Calculated percentage error in time, distance, and idle from generated driving cycles for closed-area and inter-city routes using NM method

- **Percentage error by using time spent method (TM)**

The percentage error of inter-city and city operated by shuttle bus and Salaya Link are depicted in Figure 4.2. The maximum error for time, distance, and idle of inter-city operated by shuttle buses and Salaya Link buses were 13.12%, 15.41%, and 1.12%, respectively. Moreover, the maximum error obtained for time, distance, and idle error of city routes that operated by shuttle bus are 4.38%, 6.63%, and 0.50%, respectively.

Inter-City and City Time : Distance and Idle Percentage Error (TM)

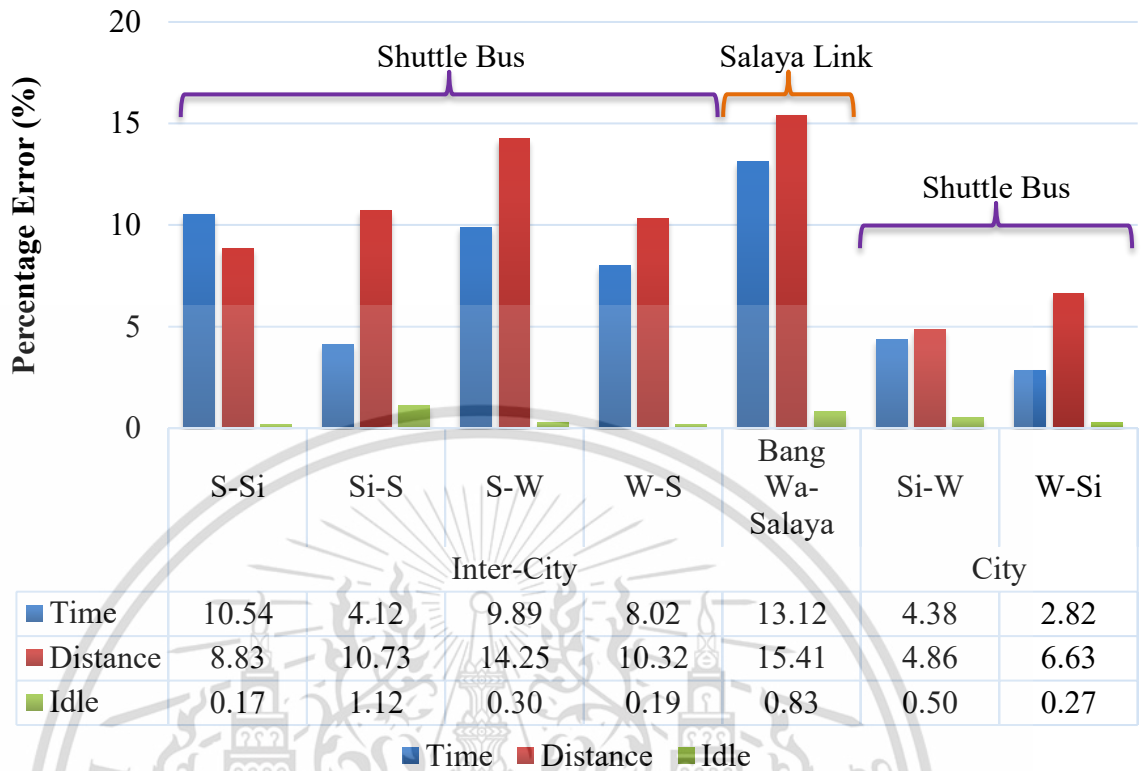

Figure 4.2 Calculated percentage error in time, distance, and idle from generated driving cycles for inter-city and city routes using TM method

4.1.2 Representative of Generated Driving Cycle

According to our study, ten candidate driving data were generated as explained in section 3.3.4. The percentage error for time, distance, and idle of generated driving cycles are less than 15%, 20%, and 2%, respectively. The most appropriated representative driving cycles for each service route were the one with the least sum of time errors.

- **Representative of closed-area driving cycle**

The representative generated driving cycle characteristic of closed-area is presented in Table 4.2. Candidate driving cycle number (4), (6), (5), and (6) are chosen to be the representative of route1, route2, route3, and route4, respectively. The maximum velocity for closed-area was 38.72 km/h with an average velocity around 15 km/h. Idle was 5 - 6 % of cycle time. The distance per cycle was 3 - 6 km. Time per cycle was 13 - 20 minutes. The generated representative driving cycles of closed-area are shown in Figure 4.3.

This material is reserved for educational use only, not allowed for commercial use.

Forbidden to modify the content, and cite the document when use.

Table 4.2 Closed-area representative driving cycles characteristics

Closed-Area	Route 1	Route 2	Route 3	Route 4
	(4)	(6)	(5)	(6)
V_{avg} (km/h)	15.06	15.90	15.05	13.32
V_{max} (km/h)	32.37	38.72	35.51	33.31
Distance (km)	3.321	5.209	5.232	3.255
Time(s)	794	1174	1252	880
Idle (s)	46 (6%)	66 (6%)	62 (5%)	77 (9%)

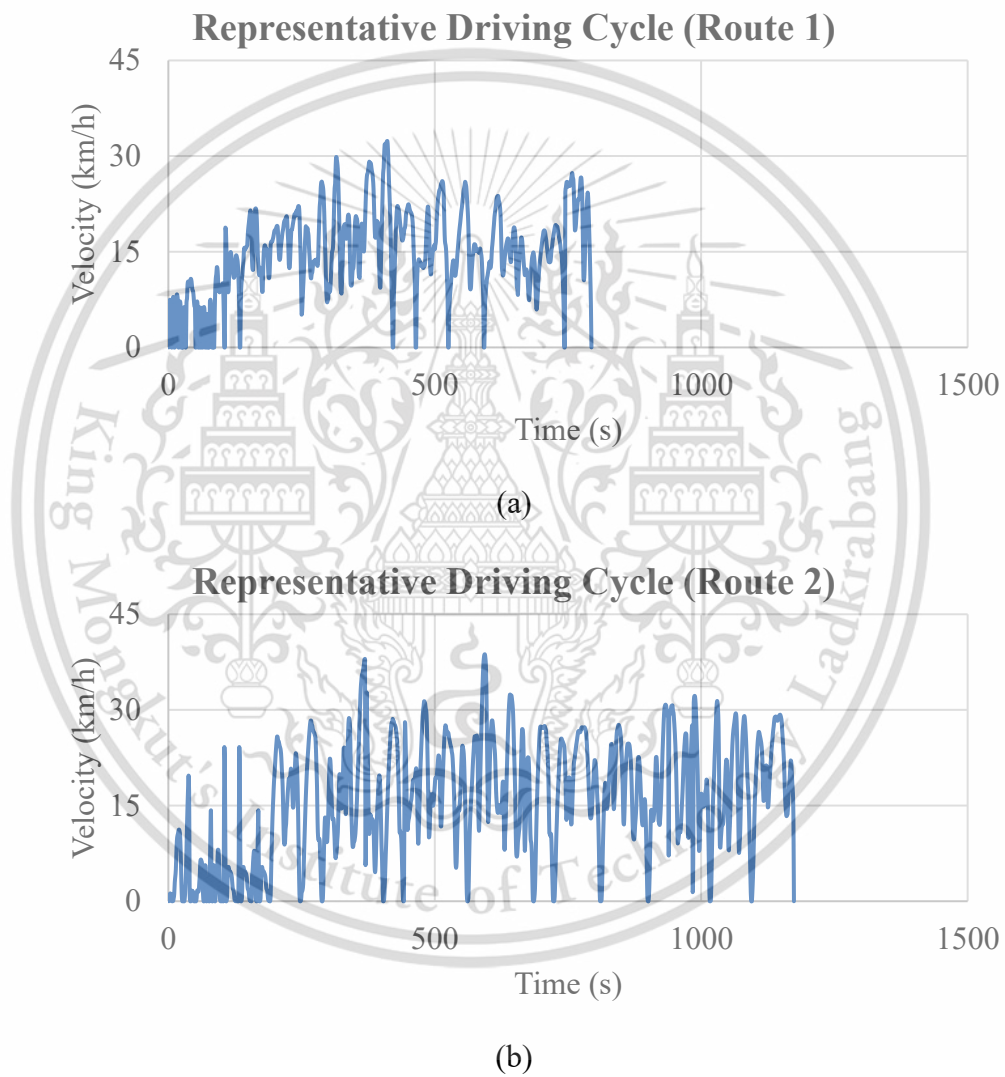

This material is reserved for educational use only, not allowed for commercial use.

Forbidden to modify the content, and cite the document when use.

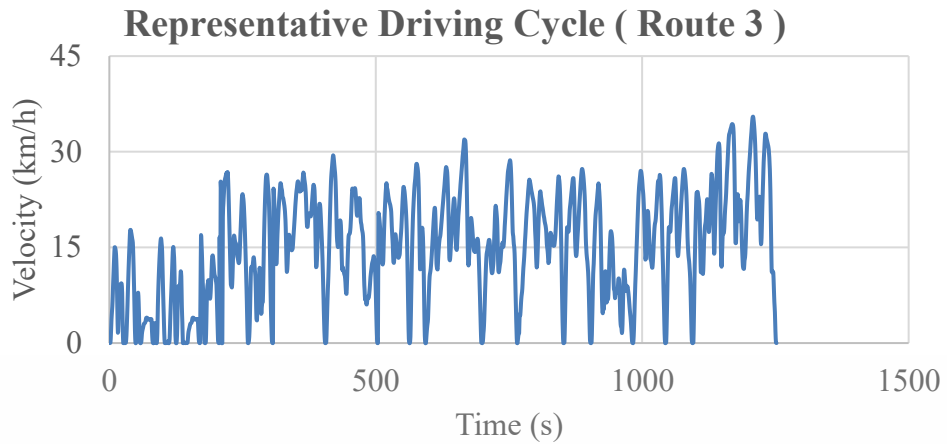

(c)

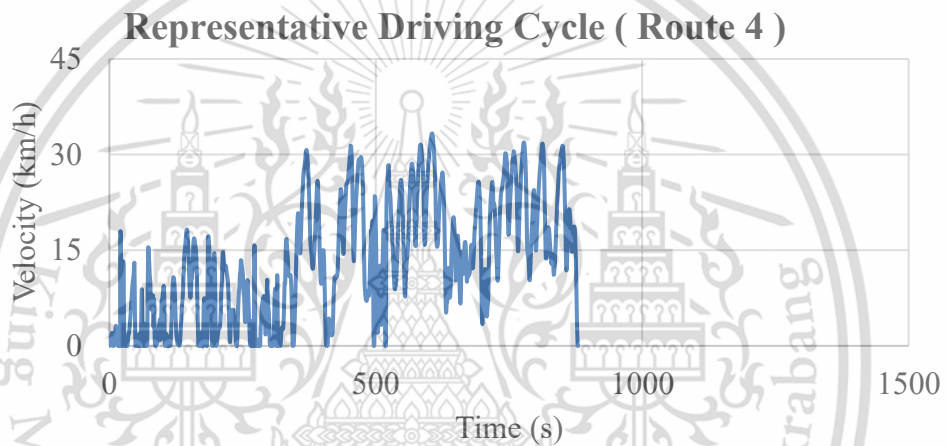

(d)

Figure 4.3 Generated representative driving cycle (Closed-area) (a) Route 1 (b) Route 2 (c) Route 3 and (d) Route 4

- **Representative of inter-city driving cycle**

The characteristic of representative generated driving cycles of inter-city is shown in Table 4.3. Candidate driving cycle number (10), (10), (8), (7), and (4) were chosen to be the representative of S-Si, Si-S, S-W, W-S, and Salaya Link, respectively. The maximum velocity for inter-city was 94.19 km/h and average velocity around 25.35 km/h. Idle duration was 21-41 % of cycle time. The distance per cycle was 15 - 35 km. Time per cycle was 35-70 minutes. The generated representative driving cycle of inter-city are shown in Figure 4.4.

Table 4.3 Inter-city representative driving cycles characteristics

Inter - City	S-Si	Si-S	S-W	W-S	Salaya Link
	(10)	(10)	(8)	(7)	(4)
V_{avg} (km/h)	32.53	18.73	23.16	23.64	28.68
V_{max} (km/h)	79.88	71.02	78.03	79.47	94.19
Distance (km)	19.238	15.065	21.105	21.229	33.920
Time(s)	2129	2896	3280	3285	4258
Idle (s)	443	1185	1065	1081	967
	(21%)	(41%)	(32%)	(33%)	(23%)

Representative Driving Cycle (S-Si)

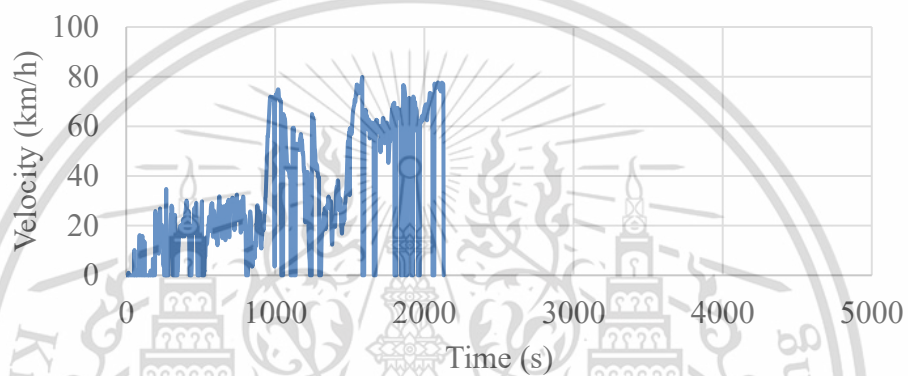

(a)

Representative Driving Cycle (Si-S)

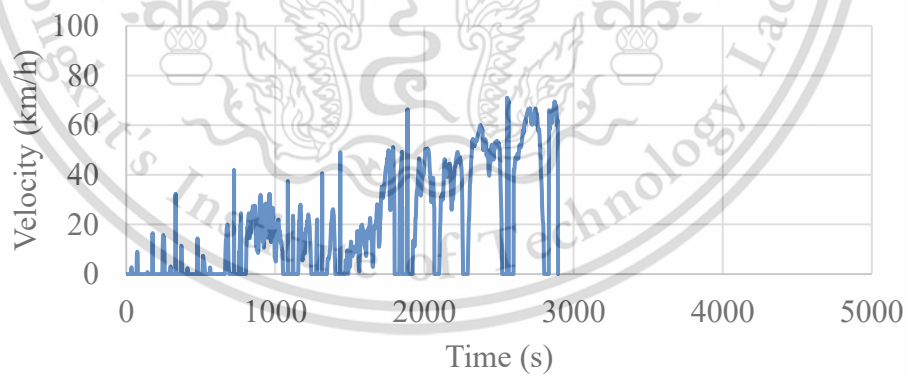

(b)

This material is reserved for educational use only, not allowed for commercial use.

Forbidden to modify the content, and cite the document when use.

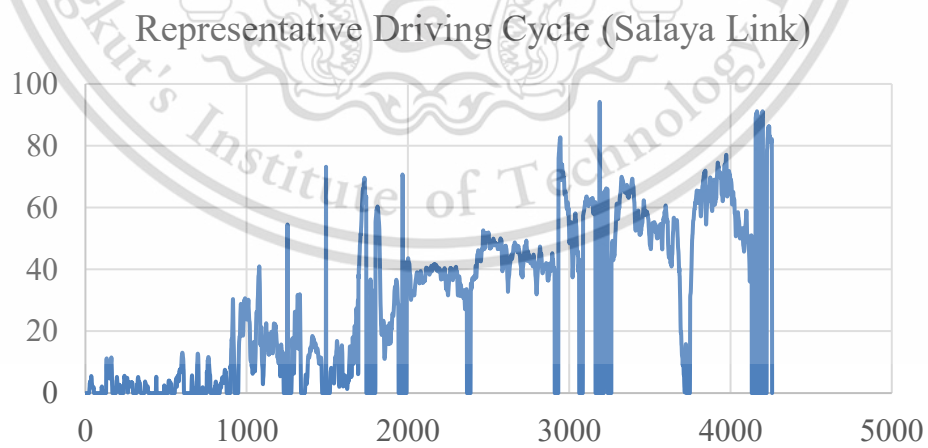
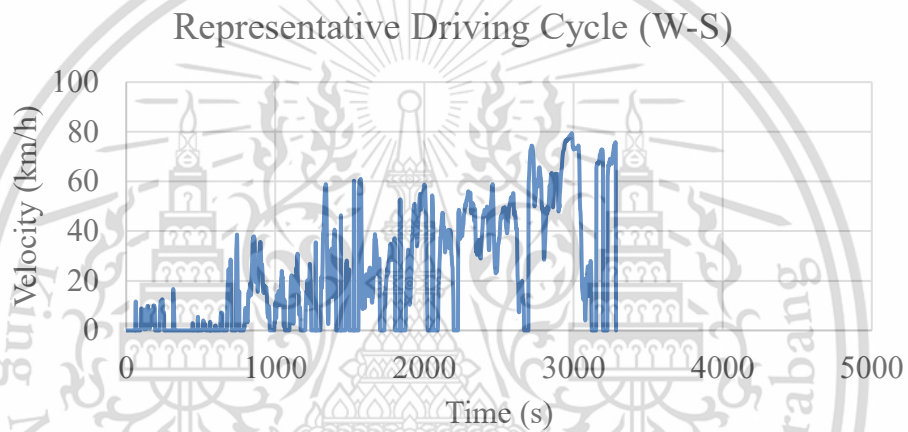
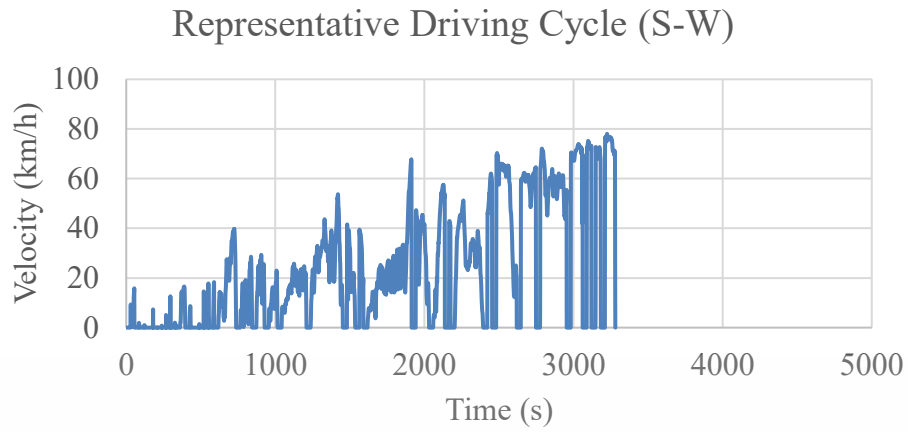

Figure 4.4 Representative driving cycle (Inter-city) (a) S-Si, (b) Si-S, (c) S-W, (d) W-S, and Salaya Link

This material is reserved for educational use only, not allowed for commercial use.

Forbidden to modify the content, and cite the document when use.

- **Representative of city driving cycle**

The representative generated driving cycle characteristic of city route is presented in Table 4.4. Candidate driving cycle number (7) and (4) were chosen to be the representative of Si-W and W-Si, respectively. The maximum velocity for inter-city was 55.02 km/h and average velocity around 11 km/h. Idle period constituted of 40-54 % of cycle time. Time per cycle was 25-47 minutes. The generated representative driving cycle of city are shown in Figure 4.5.

Table 4.4 City representative driving cycles characteristics

City	Si-W (No.7)	W-Si (No.4)
V_{avg} (km/h)	13.15	8.85
V_{max} (km/h)	50.57	55.02
Distance (km)	6.295	6.955
Time(s)	1723	2830
Idle (s)	685 (40%)	1522 (54%)

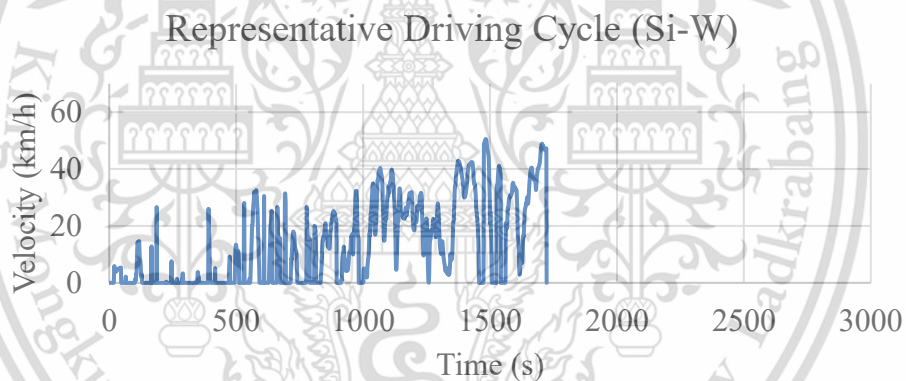

(a)

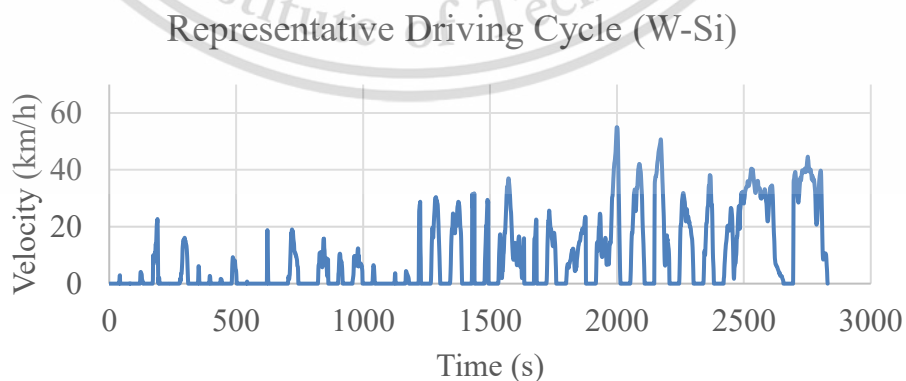

(b)

Figure 4.5 Representative driving cycle (City) (a) Si-W and (b) W-Si

This material is reserved for educational use only, not allowed for commercial use.

Forbidden to modify the content, and cite the document when use.

4.2 Energy Consumption

4.2.1 Traction energy consumption

The traction energy consumption was calculated as a function of driving speed obtained from the generated representative driving cycles. The values of traction energy consumption per cycle, in kWh, of the generated driving cycle for tram, shuttle bus, and Salaya Link service routes calculated by MATLAB Simulink program. The results are shown in Table 4.5 - Table 4.7. The maximum numbers of passengers considered in the calculations were 48, 62, and 44 for tram, shuttle bus, and Salaya Link, respectively. As a worst-case scenario, the maximum number of passengers included the standing passengers for energy consumption calculation for all routes in this study.

Table 4.5 Traction energy consumption (kWh) of closed-area routes

Closed-Area	Route 1	Route 2	Route 3	Route 4
		(4)	(6)	(5)
Energy Consumption(kWh)	1.704	2.692	2.709	1.691

Table 4.6 Traction energy consumption (kWh) of inter-city routes

Inter-City	S-Si	Si-S	S-W	W-S	Salaya Link
		(10)	(10)	(8)	(7)
Energy Consumption(kWh)	13.930	9.908	14.620	14.610	23.690

Table 4.7 Traction energy consumption (kWh) of city routes

City	Si-W	W-Si
		(7)
Energy Consumption(kWh)	3.699	4.043

This material is reserved for educational use only, not allowed for commercial use.

Forbidden to modify the content, and cite the document when use.

Traction Energy Consumption (kWh/km)

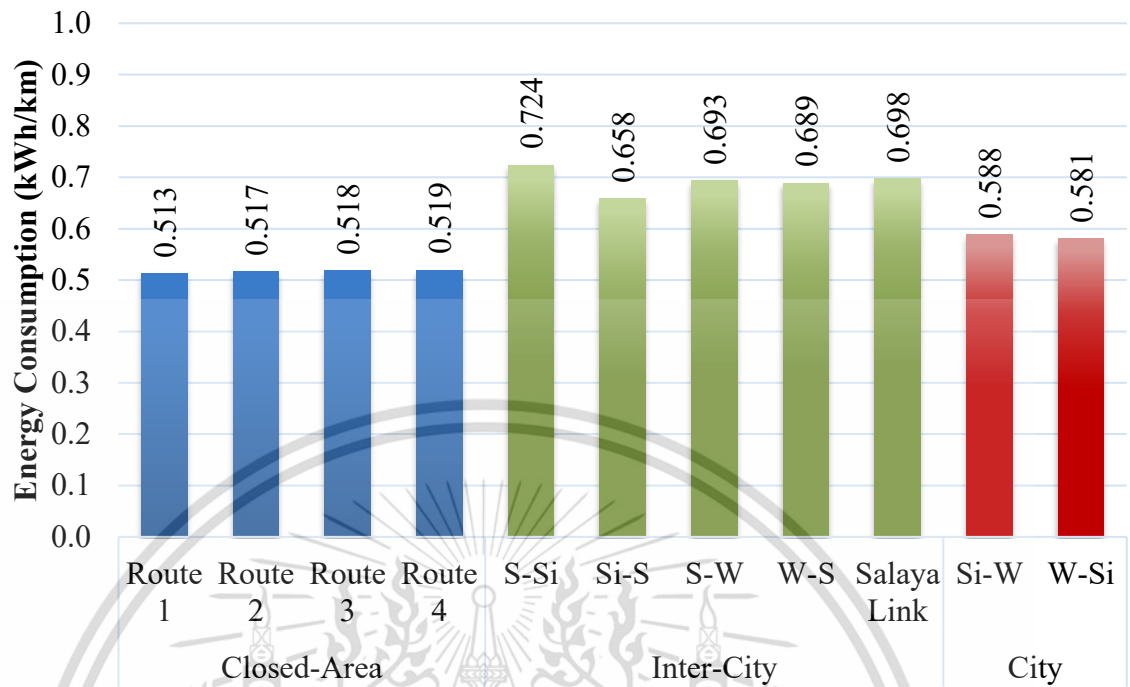

Figure 4.6 Traction energy consumption (kWh/km) of closed-area, inter-city and city routes

4.2.2 Total Energy Consumption

In addition to the energy consumption of the traction system, the consumption of EV main component and auxiliary has been taken into account. EV main components auxiliary system i.e. pneumatic pump, air condition, DC water cooling pump, steering pump, controller, and accessory as shown in Table 3.10. Energy consumption of representative driving cycle in kWh are shown in Table 4.8 - Table 4.10. Figure 4.7 reveals the energy consumption in kWh/km of total energy consumption.

Table 4.8 Total energy consumption (kWh) of closed-area routes

Closed-Area	Route 1	Route 2	Route 3	Route 4
	(4)	(6)	(5)	(6)
Energy Consumption(kWh)	4.849	7.342	4.959	3.486

Table 4.9 Total energy consumption (kWh) of inter-city routes

Inter-City	S-Si	Si-S	S-W	W-S	Salaya Link
	(10)	(10)	(8)	(7)	(4)
Energy Consumption(kWh)	22.363	21.379	27.612	27.632	40.556

Table 4.10 Total energy consumption (kWh) of city routes

City	Si-W	W-Si
	(7)	(4)
Energy Consumption(kWh)	10.524	15.253

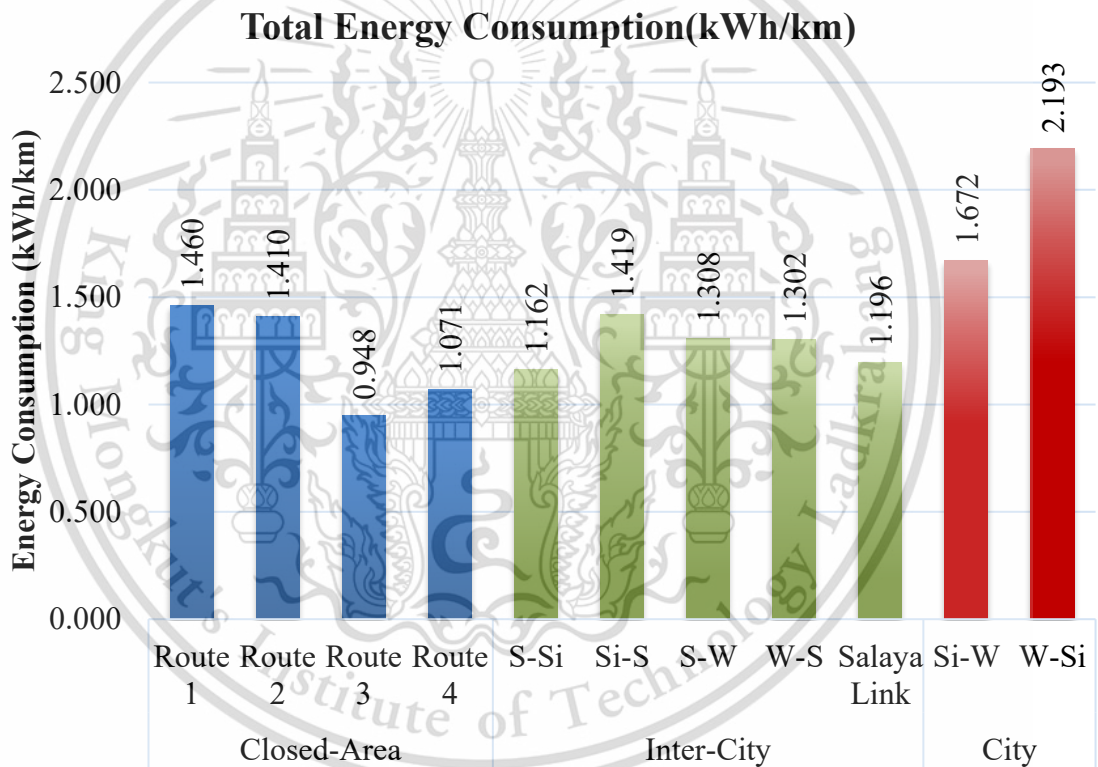

Figure 4.7 Total energy consumption (kWh/km) of closed-area, inter-city and city routes

4.3 Battery Sizing

Maximum power of battery of each route was considered in battery design as described in equation (3.10). Maximum power (P_{max}) in kW was an important factor in selecting the proper size of battery packs to be used on the EV buses. Table 4.11 presents maximum power (P_{max}) of representative driving cycle including EV components.

This material is reserved for educational use only, not allowed for commercial use.

Forbidden to modify the content, and cite the document when use.

Table 4.11 Maximum power (P_{max}) in kW of representative driving cycle including total components

P_{max} (kW)	Closed-Area	Inter-City	City
Traction Power	22.51	99.98	39.04
Total Power	36.77	114.24	53.30

The efficiency of LFP battery was assumed to be 0.94 (Pihlatie et al., 2015). The usable energy from installed battery ($E_{battery}$) of each battery size are shown in Table 4.12.

Table 4.12 The usable energy form installed battery of 100kWh, 150kWh, and 200kWh

Installed Battery Size	100 kWh	150 kWh	200 kWh
$E_{battery}$ (kWh)	94	141	188

4.3.1 Battery Sizing for Campus Bus Operation Design

The exact math for sizing battery is based on a daily power usage and the battery type. In this study, the distance was collected from an operation distance per cycle of each route. Operation distance of each route per cycle are shown in Table 4.13.

Table 4.13 Operation distance of each route per cycle

Closed-Area Routes	D_{avg} (km)	Inter-City Routes	D_{avg} (km)	City Routes	D_{avg} (km)
1	3.051	S-Si	21.10	Si-W	6.62
2	4.926	Si-S	16.87	W-Si	7.45
3	5.557	S-W	24.61		
4	3.679	W-S	16.87		
		Salaya Link	15.41		

Table 4.14 provides operation distance of each route per day (D_{day}) that was calculated by maximum average operation distance per cycle (D_{avg}) and number of cycles per day (N_{cycle}) in equation (3.17)

Table 4.14 Operation distance of each route per day

Routes	D_{avg}	N_{cycle}	D_{day}
Closed-Area	5.557	17	94.474
Inter-City	24.614,21.100	6, 2	189.884
City	7.45	3	22.347

This material is reserved for educational use only, not allowed for commercial use.

Forbidden to modify the content, and cite the document when use.

The traction battery energy required ($E_{required,t}$) and total battery energy required ($E_{required,total}$) per day based on campus bus operation for closed-area, inter-city, and city are shown in Figure 4.8.

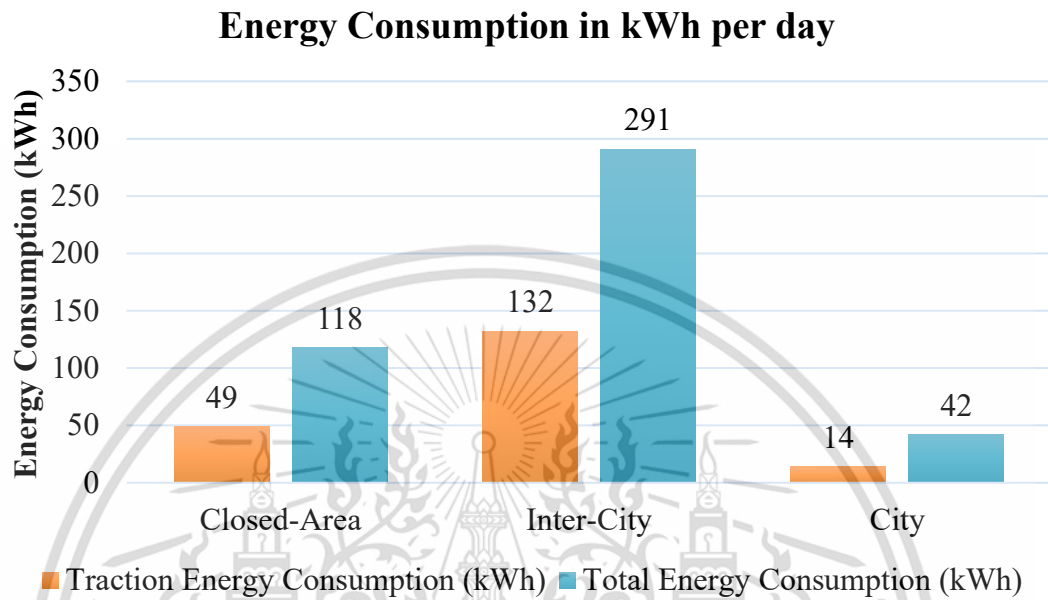

Figure 4.8 Estimated battery capacity of traction and total energy demanded per day for closed-area, inter-city, and city

In some cases the traction energy required from batteries ($E_{required,t}$) and total battery required ($E_{required,total}$) per day for campus bus operation, were found to be higher than the usable energy from installed battery ($E_{battery}$). Then, the number of traction cycles ($N_{Traction}$) and number of total cycles (N_{Total}) were calculated to estimate when the campus bus need charging the battery. This design did not allow the use of different sizes of vehicles using the charging stations. Assuming recharge at terminal stops and allows an overnight charge in every route, the maximum number of cycles operated per day for closed-area, inter-city (shuttle bus, Salaya Link), and city were 17, 8, 4, and 3, respectively. The number of traction cycles ($N_{Traction}$) and number of total cycles (N_{Total}) of each route are presented in Table 4.15 - Table 4.18

Table 4.15 The number of traction cycles ($N_{Traction}$) and number of total cycles (N_{Total}) for closed-area operated by tram.

Tram		Vehicle Range (km)		Cycles			
		Traction	Total	Traction	Total	Traction	Total
Installed Battery	100 kWh	181	75	✓	32	✗	13
	150 kWh	272	113	✓	48	✓	20
	200 kWh	363	151	✓	65	✓	27

Table 4.16 The number of traction cycles ($N_{Traction}$) and number of total cycles (N_{Total}) for inter-city operated by shuttle bus.

Shuttle Bus		Vehicle Range (km)		Cycles			
		Traction	Total	Traction	Total	Traction	Total
Installed Battery	100 kWh	129	58	✗	5	✗	2
	150 kWh	194	88	✗	8	✗	4
	200 kWh	259	117	✓	11	✗	5

Table 4.17 The number of traction cycles ($N_{Traction}$) and number of total cycles (N_{Total}) for inter-city operated by Salaya Link.

Salaya Link		Vehicle Range (km)		Cycles			
		Traction	Total	Traction	Total	Traction	Total
Installed Battery	100 kWh	129	58	✓	8	✗	4
	150 kWh	194	88	✓	13	✓	6
	200 kWh	259	117	✓	17	✓	8

Table 4.18 The number of traction cycles ($N_{Traction}$) and number of total cycles (N_{Total}) for city operated by shuttle bus.

Shuttle Bus		Vehicle Range (km)		Cycles			
		Traction	Total	Traction	Total	Traction	Total
Installed Battery	100 kWh	153	47	✓	21	✓	6
	150 kWh	230	71	✓	31	✓	10
	200 kWh	307	95	✓	41	✓	13

The installed battery and charging station cost of traction and total consumption in each route was equally because the fixed number charging station for campus bus design. The total cost of traction energy consumption ($Cost_{Traction}$) and total energy consumption ($Cost_{Total}$) for closed-area, inter-city, and city are shown in Table 4.19.

Table 4.19 Battery and charging stations cost for closed-area, inter-city, and city

Battery & Charging Stations Cost (THB)	Type	Closed-Area	Inter-City	City
Installed Battery 100 kWh	Traction Total	3,758,163	5,419,813	3,758,163
Installed Battery 150 kWh	Traction Total	4,946,186	6,607,837	4,946,186
Installed Battery 200 kWh	Traction Total	6,041,032	7,702,682	6,041,032

4.3.2 Battery Sizing Estimated using a Fixed Vehicle Range Approach

a) Charging Station Location

In this section, the charging location of vehicle with desired operating of ranges 50 km - 200 km under various the installed batteries were designed. The economics of battery sizing and charging station for each route were calculated to choose the suitable cost for investment. The charging station location were considered from different the range, of battery size between 100kWh, 150kWh, and 200kWh. The ranges of start and end location (D_{fix}) were assumed at 50km, 100km, 150km, and 200km. The dwell time was assumed to be enough for charging. Charging station location was assumed to install at the end of every driving range. The driving range under varied the battery sizes were shown in Table 4.20. The same battery size of each route had the different charging station distance because of the driving cycle characteristic.

Table 4.20 The charging station location under varied the battery sizes

Charge Station (km)	Closed-Area		Inter-City		City		
	$D_{charger,t}$	$D_{charger,total}$	$D_{charger,t}$	$D_{charger,total}$	$D_{charger,t}$	$D_{charger,total}$	
Installed Battery	100 kWh	181	76	135	73	160	48
	150 kWh	272	115	203	110	241	72
	200 kWh	363	153	271	147	321	97

The number of charging stations depended on the driving range under the battery sizes. The number of charging station for vehicle range 50 - 200 km are presented in Table 4.21-Table 4.24.

b) Battery Sizing

Table 4.21 Number of charging stations for 50 km

	Closed-Area		Inter-City		City	
	Traction	Total	Traction	Total	Traction	Total
Installed Battery 100 kWh	1	1	1	1	1	2
Installed Battery 150 kWh	1	1	1	1	1	1
Installed Battery 200 kWh	1	1	1	1	1	1

Table 4.22 Number of charging stations for 100 km

	Closed-Area		Inter-City		City	
	Traction	Total	Traction	Total	Traction	Total
Installed Battery 100 kWh	1	2	1	2	1	3
Installed Battery 150 kWh	1	1	1	1	1	2
Installed Battery 200 kWh	1	1	1	1	1	2

Table 4.23 Number of charging stations for 150 km

	Closed-Area		Inter-City		City	
	Traction	Total	Traction	Total	Traction	Total
Installed Battery 100 kWh	1	2	2	3	1	4
Installed Battery 150 kWh	1	2	1	2	1	3
Installed Battery 200 kWh	1	1	1	2	1	2

Table 4.24 Number of charging stations for 200 km

	Closed-Area		Inter-City		City	
	Traction	Total	Traction	Total	Traction	Total
Installed Battery 100 kWh	2	3	2	3	2	5
Installed Battery 150 kWh	1	2	1	2	1	3
Installed Battery 200 kWh	1	2	1	2	1	3

The fixed vehicle range of 50 km could be installed battery size of 100 kWh for all routes excepted city route. This was because of the driving characteristic and air-condition. Battery sizes and charging station location depended on the target vehicle distance and driving cycle characteristics. Then, the real-world driving pattern is a significant parameter to battery size design and economy. The total cost for electric public bus for driving by traction energy consumption ($Cost_{Traction}$) and total energy consumption ($Cost_{Total}$) under varied fix vehicle ranges are illustrated in Figure 4.9.

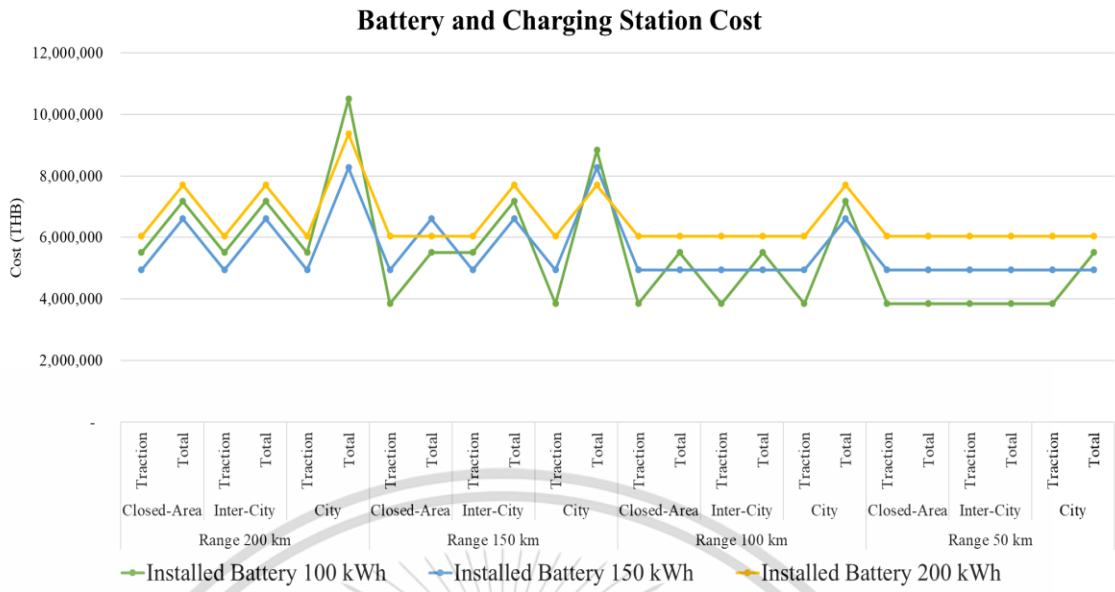
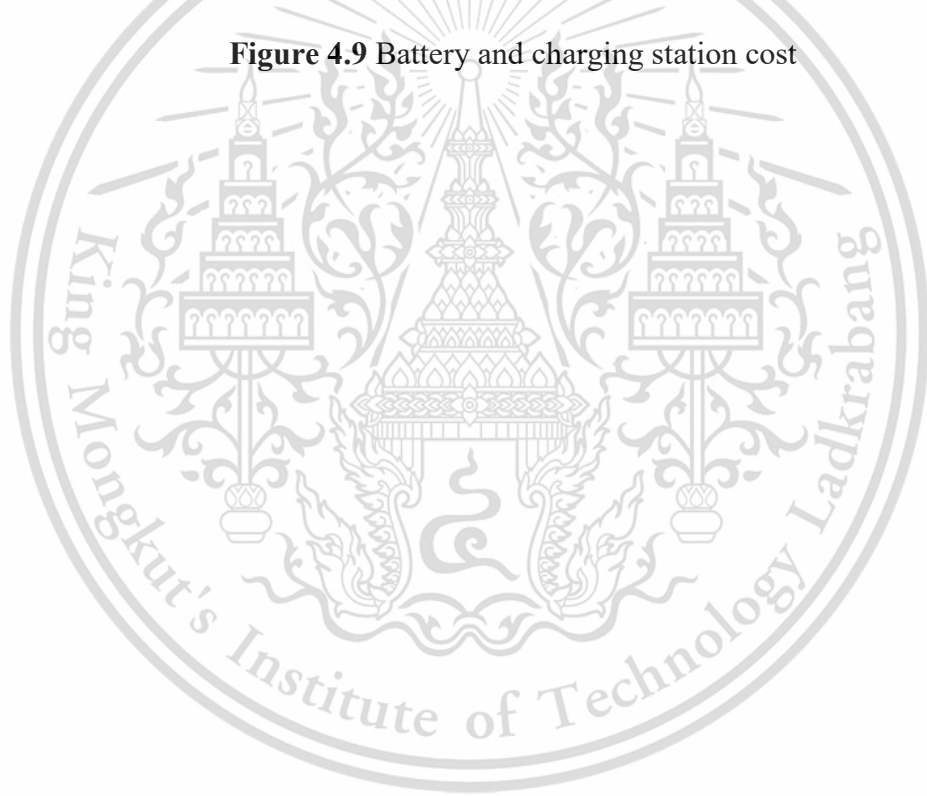

Figure 4.9 Battery and charging station cost



CHAPTER 5

DISCUSSION

5.1 Driving Cycle

VBox (VB20SL3, Racelogic Ltd.) was used in this study as a GPS equipment to record vehicle travel speeds at a rate of 20Hz. Three chosen types of service routes i.e. closed-area, inter-city, and city had a different characteristic of travelling. Using a GPS-based in the inter-city and city route led to some difficulties in the data collecting process device when in operation. The stability of the signal deteriorated when the device vehicle was close to high-rise buildings or under flyovers, in particular inter-city and city routes, which, in turn, adversely affected the accuracy of the collected data. The number of passengers was a parameter that also affected the energy consumption. In this work passengers were counted at every collected driving cycle.

Form this study, the driving characteristics i.e. time, distance, and idle were analysed from collected speed-time data. In this study, there were two methods of microtrip segmentation i.e. number of microtrips method (NM) and time spent of microtrip method (TM). In the driving cycle generation process, the microtrips obtained from NM and TM method were considered.

Number of microtrips (NM) in each speed range were counted and calculated into percentage for determination of speed range time (T_{range}). T_{range} was used for controlling time in generating driving cycle process. Idle time was ignored in this method. It could be seen from the results that the representative driving cycle of closed-area was the only route that cloud be employed NM method, since the calculated error values of time, distance, and idle were in the acceptable value of 15%, 20%, and 2%, respectively.

On the contrary, although percentage error of inter-city was in 15% but distance and idle error were in the interval 30-80% which was not acceptable. This is believed to be due to the long length of microtrip when speed exceeded 30 km/hr, number of microtrip percentage in NM method were difficulties encountered in generating a driving cycle. Therefore, with these errors, it could be said that NM methods was not appropriated for generating driving cycle.

To solve the problem above, the time spent method (TM) was introduced for solving the problem of distance and idle errors with the speed range higher than 30 km/h. Time spent in microtrip in each speed ranges (T_{range}) were calculated into percentage. Then, it was used as a time range limit for controlling the amount of time allowed at each speed range in driving cycle generation process. Idle time were introduced into generated driving cycles by equally dividing the total idle time collected for each trip to be placed as regular intervals between each microtrip. Sum of time error (E) was found to be in 15% and the driving cycles were found to be generated with relative ease compared to those using NM method. Furthermore, the resulting error in distance and idle for inter-city and city routes, in which a speed range was 0-90 km/h, were less than 20% and 2%, respectively.

According to the results, TM method was a more suitable method for microtrip data segmentation in preparing the microtrip database to be used in driving cycle generation for every speed ranges encountered in this study. This was based on the obtained errors in time, distance, and idle of the generated driving cycle which were all being within the acceptable ranges. Furthermore, the generated driving cycle is close to the actual characteristic data pattern including idle.

5.2 Energy Consumption

In this study, the EV energy consumption rate (kWh/km) was calculated based on representative driving cycles from various operating routes. As a result, the energy consumption was not significantly different within each route type because the driving data were collected from the same operating area, with the same vehicle type, and similar driving behaviour. Thus, the average energy consumption of each route was chosen to be the representative energy consumption. The traction energy consumption rate of closed-area, city, and inter-city was estimated to be 0.517 kWh/km, 0.692 kWh/km, and 0.584 kWh/km, respectively. The analysis showed that traction energy consumption was based on only a driving cycle, where the higher average speed (V_{avg}) and maximum speed (V_{max}), the more energy consumption rate (kWh/km).

This study also evaluated the impact of main component and auxiliary systems including pneumatic pump, air condition, DC water cooling pump, steering pump, controller, and accessory load on the energy consumption of electric vehicle. The total energy consumption rate of closed-area, city, and inter-city was estimated to be 1.222

This material is reserved for educational use only, not allowed for commercial use.

Forbidden to modify the content, and cite the document when use.

kWh/km, 1.277 kWh/km, and 1.932 kWh/km, respectively. The total energy consumption rate did not only depend on a driving cycle but also idle time because air-condition would be working all the time since starting point. The results showed that idle period was the significant parameter that increased total EV energy consumption rate for inter-city and city routes. However, total energy consumption of closed-area was still high, even though the idle was very low (9%). Since, the closed-area had short operating distance (3-6 km), this indicated that the air conditioner still consumed a lot of energy especially for a short operating route.

Overall, it could be concluded that the traction energy consumption rate ($E_{Traction}$) in kWh/km based on driving cycle was depending on average speed (V_{avg}) and maximum speed (V_{max}). Idle was also another significant parameter that impact to the increasing of total energy consumption rate (E_{Total}) in kWh/km for all routes. The representative traction and total energy consumption rate in kWh/km of obtained in this study can be the representative for campus bus driving in closed-area, inter-city, and city.

5.3 Battery Sizing

In this study, there are two different approaches for battery sizing section i.e. campus bus operation and fixed vehicle range. The difference between two cases were number of charging stations, charger location and driver timetable. The battery sizes were varied to 100 kWh, 150 kWh and 200 kWh for two sceneries. The total energy consumption for battery sizing ($E_{required,total}$) for all route were 60% higher than traction energy consumption for battery sizing ($E_{required,t}$).

The battery sizing for campus bus operation referred to the real driving timetable from one sample of Thai universities. The operated distance per day (D_{day}) for closed-area, inter-city, and city were 95 km, 190 km, and 23 km, respectively. The number of traction cycles ($N_{Traction}$) and number of total cycles (N_{Total}) were calculated to estimate when the campus bus would need charging the battery. The charging stations were fixed at the terminal stop. Closed-area has the over energy consumption rate when including air condition for usage. Then, closed-area is not suitable for using air condition in short operated distance. However, inter-city and city were not avoidable to install air-condition on campus bus for passenger convenience. Then, the representative energy consumption, in kWh, for battery sizing for closed-area, inter-city, and city were 49 kWh, 291 kWh, and 42 kWh, respectively. From the results, closed-area could install

This material is reserved for educational use only, not for commercial use.

Forbidden to modify the content, and cite the document when use.

battery size 100 kWh for operation all day by not charging based on traction energy consumption for battery sizing ($E_{required,t}$). Based on total energy consumption for battery sizing ($E_{required,total}$), the suitable battery size for inter-city in one day is 150 kWh and need charging one time after driving finished 4 cycles of service. City could operate 3 cycles for all day by installed battery size 100 kWh. The total cost of battery and charging station for closed-area, inter-city, and city routes were 3,758,163 THB, 6,607,837 THB, and 3,758,163 THB.

In case of fixed operation distance, the ranges of start and end location (D_{fix}) were assumed at 50km, 100km, 150km, and 200km. The total energy consumption for battery sizing ($E_{required,total}$) and traction energy consumption for battery sizing ($E_{required,t}$) were calculated under varied battery sizes. The charging station location was dependant on the driving range based on each battery size by using the distance of located charging station for traction driving range ($D_{charger,t}$) and the distance of located charging for total driving range ($D_{charger,total}$). The number of chargers for traction driving range ($N_{charger,t}$) and the number of chargers for total driving range ($N_{charger,total}$) were used for estimated suitable total cost for each route. The number of chargers depend on the energy consumption of each fix vehicle range. The lowest battery and charging station cost use to indicate the suitable battery size for each vehicle range. For 200 km, all routes should install battery of 150 kWh. For 150 km, closed-area and inter-city should install battery size 100 kWh and 150 kWh, respectively. While city install battery size 100 kWh based on traction energy consumption and 200 kWh based on total energy consumption. For 100 km, battery size 100 kWh were adequate to install for traction energy consumption for all route and 150 kWh for total energy consumption. For 50 km, battery size 100 kWh was enough for all route except city route was based on total energy consumption, would need a battery size of 150 kWh.

From this study, the battery sizing design was depended on the energy consumption required per day. In case of campus bus operation, battery size for closed-area and city in one day are 100 kWh by not charging. Inter-city could install battery size 150 kWh and need charging one per day. In case of fixed vehicle range, total cost for electric campus bus depended on the driving cycles, vehicle range, and number of charging stations.

This material is reserved for educational use only, not allowed for commercial use.

Forbidden to modify the content, and cite the document when use.

CHAPTER 6 CONCLUSIONS AND RECOMMENDATIONS

In this study, closed-area, inter-city, and city route operated by service tram and buses were investigated. The four trams were operated in a closed-area, while the shuttle buses were employed in an inter-city and city routes. In the process of developing the representative driving cycle for energy consumption calculation, the three main operating parameters of interest selected were time, distance, and idle period. They were used in the development of the driving cycle as a judging criterion in the selection of suitable candidates through a comparison of their corresponding errors. The candidate which had the smallest percentage error was selected as the representative driving cycle. Two segmentation methods i.e. number of microtrips method (NM) and time spent of microtrip method (TM) were used for driving cycle development. NM method used the number of microtrip percentage for the parameter to develop the driving cycle, but this method did not focus on idle time and time spent in each speed range. This made the percentage errors of inter-city and city excessively large when using NM method. In TM method, time spent of microtrip and idle time were used for parameters to develop the driving cycle. This method reduced the error that occurred in NM method. From above reasons, TM method was considered the most appropriate method for generated representative driving cycle for all route types.

The analysis indicated that the energy consumption depended on the driving pattern. The estimated energy consumption of campus trams and shuttle buses were carried out by performing the calculation which included actual driving data velocity, vehicle position (latitude and longitude), and time. The energy consumption was based on the fundamental theory of vehicle dynamics and the basic relationships between power and force. For this study, the energy consumption rates were not significantly different within each route because the driving data were collected from the same operating area, same vehicle type, and similar driving behaviour. Therefore, the traction energy consumption rate for closed-area, inter-city, and city 0.517 kWh/km, 0.692 kWh/km, and 0.584 kWh/km, respectively. By including other electrical components, the total energy consumption rate of closed-area, city, and inter-city was estimated to be 1.222 kWh/km, 1.277 kWh/km, and 1.932 kWh/km, respectively. These was considered to be the representative energy consumption for the design of electric bus based on this study.

From two cases of battery sizing, campus bus operation and fixed vehicle range, the battery sizing had many different possible designs. Maximum power of each route was used in calculation process such the battery size must have enough power to provide for traction. For designing the campus bus battery size, the charging station were fixed at the terminal stop. The number of cycles that electric campus bus could operate for all routes service were depended on energy consumption rate calculated from real driving cycle and battery sizes. From the results, suitable battery size for closed-area and city routes were 100 kWh. On the other hand, 150 kWh battery size was recommended for inter-city route. In fix vehicle range case, not only the sufficient range to reach the destination but also the economics of battery and charging station were considered for obtaining cost saving. In this case, the results shown that battery size 100 kWh was sufficient for vehicle range at 50 km and 100 km base on traction energy consumption and battery size 150 kWh was suitable based on total energy consumption. At vehicle range 150 km, only city route based on total energy consumption installed 200 kWh to provide enough the power. While at vehicle range 200 km installed battery size 150 kWh for all route type. The main EV component such as air-condition had significant effect to the total energy consumption at the short vehicle range was less pronounced at the long vehicle range. From these reasons, to design the optimum cost for the new route for electric vehicle, long range application is not suitable to install larger battery size than that of short range. This is because costs were depended on the different driving characteristic of each route, energy consumption rate and number of charging stations. The results from this study could be useful for the electric vehicle system design such as required size of energy storage system, charging station, and operation design.

REFERENCES

- Barlow, T., Latham, S., Mccrae, I., & Boulter, P. (2009). *A reference book of driving cycles for use in the measurement of road vehicle emissions*. TRL Published Project Report. <https://doi.org/10.1108/WJSTSD-06-2014-0009>
- Chen, J.-S. (2015). Energy Efficiency Comparison between Hydraulic Hybrid and Hybrid Electric Vehicles. *Energies*, 8(6), 4697–4723. <https://doi.org/10.3390/en8064697>
- De Cauwer, C., Van Mierlo, J., & Coosemans, T. (2015). Energy consumption prediction for electric vehicles based on real-world data. *Energies*, 8(8), 8573–8593. <https://doi.org/10.3390/en8088573>
- Dong, J., Liu, C., & Lin, Z. (2014). Charging infrastructure planning for promoting battery electric vehicles: An activity-based approach using multiday travel data. *Transportation Research Part C: Emerging Technologies*, 38, 44–55. <https://doi.org/10.1016/j.trc.2013.11.001>
- Feroldi, D., & Carignano, M. (2016). Sizing for fuel cell/supercapacitor hybrid vehicles based on stochastic driving cycles. *Applied Energy*, 183, 645–658. <https://doi.org/10.1016/j.apenergy.2016.09.008>
- Fiori, C., Ahn, K., & Rakha, H. A. (2016). Power-based electric vehicle energy consumption model: Model development and validation. *Applied Energy*, 168, 257–268. <https://doi.org/10.1016/j.apenergy.2016.01.097>
- Fu, X., Wang, H., Cui, N., & Zhang, C. (2014). Energy management strategy based on the driving cycle model for plugin hybrid electric vehicles. *Abstract and Applied Analysis*, 2014. <https://doi.org/10.1155/2014/341096>
- Galgamuwa, U., Perera, L., & Bandara, S. (2015). Developing a General Methodology for Driving Cycle Construction: Comparison of Various Established Driving Cycles in the World to Propose a General Approach. *Journal of Transportation Technologies*, 05(04), 191–203. <https://doi.org/10.4236/jtts.2015.54018>
- GHAFFAR, F. B. A., & A. (2015). *Driving Cycle for Small and Medium Duty Engine: Case Study of IPOH*. Universiti Tun Hussein Onn Malaysia.
- He, J., Ao, G., Guo, J., Chen, Z., & Yang, L. (2009). Hybrid electric vehicle with flywheel energy storage system. *WSEAS Transactions on Systems*, 8(5), 638–648.
- Hung, W. T., Tong, H. Y., Lee, C. P., Ha, K., & Pao, L. Y. (2007). Development of a practical driving cycle construction methodology: A case study in Hong Kong. *Transportation Research Part D: Transport and Environment*, 12(2), 115–128. <https://doi.org/10.1016/j.trd.2007.01.002>
- IEA, I. E. A. (2017). Global EV Outlook 2017: Two million and counting. *IEA Publications*, 1–71. <https://doi.org/10.1787/9789264278882-en>
- Nesamani, K. S., & Subramanian, K. P. (2011). Development of a driving cycle for

This material is reserved for educational use only, not allowed for commercial use.

Forbidden to modify the content, and cite the document when use.

- intra-city buses in Chennai, India. *Atmospheric Environment*, 45(31), 5469–5476. <https://doi.org/10.1016/j.atmosenv.2011.06.067>
- Pihlatie, M., Kukkonen, S., Halmeaho, T., Karvonen, V., & Nylund, N. O. (2015). Fully electric city buses - The viable option. *2014 IEEE International Electric Vehicle Conference, IEVC 2014*. <https://doi.org/10.1109/IEVC.2014.7056145>
- Rogge, M., Wollny, S., & Sauer, D. U. (2015). Fast charging battery buses for the electrification of urban public transport-A feasibility study focusing on charging infrastructure and energy storage requirements. *Energies*, 8(5), 4587–4606. <https://doi.org/10.3390/en8054587>
- S. Tamasnya, S. Chungpaibulpatana, B. L. (2009). Development of a driving cycle for the measurement of fuel consumption and exhaust emissions of automobiles in Bangkok during peak periods. *International Journal of Automotive Technology*, 10, 251–264. <https://doi.org/10.1007/s12239>
- Shi, S., Lin, N., Zhang, Y., Cheng, J., Huang, C., Liu, L., & Lu, B. (2016). Research on Markov property analysis of driving cycles and its application. *Transportation Research Part D: Transport and Environment*, 47, 171–181. <https://doi.org/10.1016/j.trd.2016.05.013>
- Thai Electric Vehicle Co., L. (TEV). (2016). Thai Electric Vehicle. Retrieved from <http://www.tev.co.th/about.php>
- Tie, S. F., & Tan, C. W. (2013). A review of energy sources and energy management system in electric vehicles. *Renewable and Sustainable Energy Reviews*, 20, 82–102. <https://doi.org/10.1016/j.rser.2012.11.077>
- Vancouver, C. of. (2017). Electric Vehicles, (March). Retrieved from <http://vancouver.ca/streets-transportation/electric-vehicles.aspx>
- Volkswagen Academy. (2013). Basics of Electric Vehicles Design and Function. U.S.A: Volkswagen Group of America, Inc.
- Wu, X., Freese, D., Cabrera, A., & Kitch, W. A. (2015). Electric Vehicles' Energy Consumption Measurement and Estimation. *2014 Transportation Research Part D: Transport and Environment*, 34, 52–67. <https://doi.org/10.1016/j.trd.2014.10.007>
- Zhu, J., Shi, Q., & Zhou, J. (2011). The city bus driving cycle construction. In *2011 2nd International Conference on Mechanic Automation and Control Engineering, MACE 2011 - Proceedings* (pp. 2687–2690). <https://doi.org/10.1109/MACE.2011.5987538>

APPENDIX A VBOX GPS EQUIPMENT SPECIFICATION

VB20SL3 20Hz GPS Data Logger With Slip, Pitch and Roll Angle

User Guide



Features

- Non-contact 20Hz speed and distance measurement using GPS
- VCI CAN input for connection to external CAN systems
- Slip, Pitch and Roll Angle and True Heading measurement
- 1 x CAN bus interface (on two sockets to allow daisy-chaining)
- USB for live data, configuration, upgrading and SD data transfer
- RS232 serial interface backup for live data and configuration
- SD Card logging
- 2 x 16bit user-configurable analogue outputs
- 2 x user-configurable digital outputs
- Brake trigger input with 210KHz scan rate
- Input voltage 6V to 30V operating range
- Logging of up to 20 data channels, in addition to up to 13 standard GPS channels
- Logging and serial rates configurable between 1Hz and 20Hz

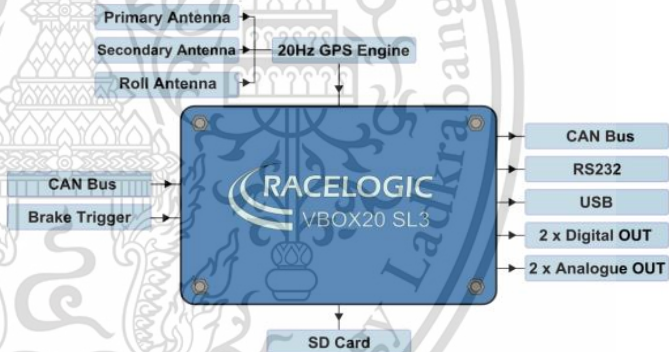

Digital Inputs

The DIGITAL I/O socket contains the two digital inputs for the VB20SL3, accessed by connecting to different combinations of the three pins.

The first digital input is most commonly referred to as the brake trigger input. This input is connected to an internal timer capture module that is able to record precisely an event time for use in brake distance calculation. This period of time is called the trigger event time, and is logged as the value in milliseconds between the last GPS sample and the trigger event. Typically, this will be connected to a pressure switch placed on the brake pedal, however a hand-held brake trigger is also available to allow the user to record marker events for other purposes.

The second digital input is used to control the VBOX's logging; a remote logging on/off switch is available for ease of use and when the front panel switch is not accessible.

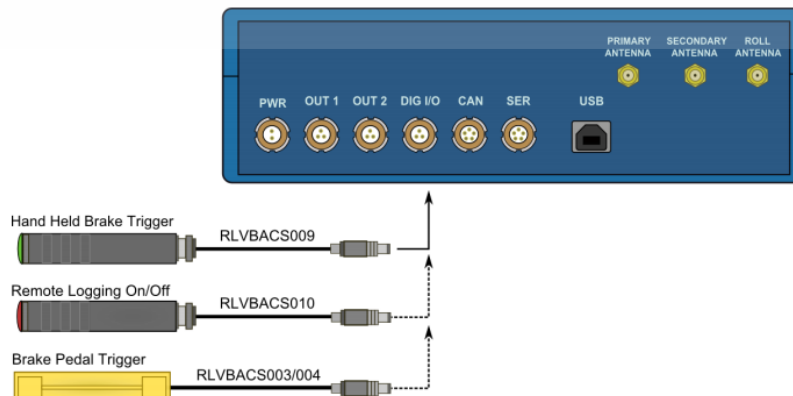

This material is reserved for educational use only, not allowed for commercial use.

Forbidden to modify the content, and cite the document when use.

Specification

GPS			
Velocity		Distance	
Accuracy	0.1 Km/h (averaged over 4 samples)	Accuracy	0.05% (<50cm per Km)
Units	Km/h or Mph	Units	Metres / Feet
Update rate	20 Hz	Update rate	20Hz
Maximum velocity	1000 Mph	Resolution	1cm
Minimum velocity	0.1 Km/h	Height accuracy	6 Metres 95% CEP**
Resolution	0.01 Km/h	Height accuracy with DGPS	2 Metres 95% CEP**
Brake Stop Accuracy		Time	
Accuracy	+/- 10cm	Resolution	0.01 s
Absolute Positioning		Accuracy	0.01 s
Accuracy	3m 95% CEP**	Pitch and Roll Angle	
Accuracy with DGPS	To 40cm 95% CEP**	Accuracy	<1.0° rms at 0.5m antenna separation
Update rate	20 Hz		<0.25° rms at 2m antenna separation
Resolution	1 cm	Power	
Slip Angle		Input Voltage range	6V to 30V DC
Accuracy	<0.5° rms at 0.5m antenna separation	Current	Typically 560mA
	<0.1° rms at 2m antenna separation	Environmental and physical	
YAW Rate		Weight	Approx 500 grammes
Yaw rate RMS Noise	0.75 degrees per second***	Size	119mm x 128mm x 30mm
Acceleration		Operating temperature	-30°C to +60°C
Accuracy	0.5%	Storage temperature	-40°C to +80°C
Maximum	20 G	Industrial Protective Class (with case closed)	IP 64
Resolution	0.01 G	Definitions	
Update rate	20Hz	** CEP = Circle of Error Probable	
Memory		95% CEP (Circle Error Probable) means 95% of the time the position readings will fall within a circle of the stated diameter	
SD/MMC Card	Dependent on flash card capacity*		
Recording time	* Approximately 4.3Mb per hour used when logging GPS data at 20Hz		

*** Note that for comparison, the VBOX YAW02 or IMU rate sensor has an RMS noise of 0.05 degrees per second, so it should be noted that the Slip Angle sensor calculated YAW rate is significantly noisier than a solid state sensor for yaw rate measurement.

Outputs			
CAN Bus		Digital	
Bit rate	Format: Motorola 125Kbit/s, 250Kbit/s, 500Kbit/s & 1Mbit/s selectable baud rate	Frequency range	DC to 44.4KHz
Identifier type	Standard 11bit or extended 2.0A	Default setting *	25Hz per Km/h (0 to 400Km/h)
Data available	Satellites in View, Latitude, Longitude, Velocity, Heading, Altitude, Vertical velocity, Distance, Longitudinal acceleration & lateral acceleration, Distance from trigger, Trigger time, trigger Velocity, True heading, Slip angle, Pitch Angle, Yaw Rate, Lateral Velocity, Roll Angle	Accuracy	90 pulses per metre
Analogue		Update rate	0.1Km/h
Voltage range	-5V to 5V DC		20Hz
Default setting *	Velocity 0.0125Volts per Km/h (0 to 400Km/h)	* The range settings can be adjusted by the user in software or via the front panel buttons	
Accuracy	0.1 Km/h		

Inputs	
CAN Bus	Format: Motorola
VCI CAN mode	Up to 16 channels from any external CAN module
Raceologic modules mode	Up to 20 channels from any combination of ADC02, ADC03, FIM02, TC8, Yaw sensor or CAN01
Digital	
Brake/Event Trigger	Selectable signal polarity. 16bit timer capture with 5µs resolution
On/Off Logging control	Remote log control from hand-held switch

This material is reserved for educational use only, not allowed for commercial use.

Forbidden to modify the content, and cite the document when use.

APPENDIX B DRIVING CYCLE CHARACTERISTIC

(a) Closed-Area (Tram)

Table 1 Tram (Route1) Driving Characteristics

Velocity Ranges	V_{avg} (km/h)	V_{max} (km/h)	Number of Microtrips		T_{range} (s)
			Microtrips	N (%)	
$0 < V \leq 10$	5.09	19.41	47	16.73%	252
$10 < V \leq 20$	16.08	34.67	220	78.29%	542
$20 < V \leq 30$	20.62	35.16	14	4.98%	8

Table 2 Tram (Route2) Driving Characteristics

Velocity Ranges	V_{avg} (km/h)	V_{max} (km/h)	Number of Microtrips		T_{range} (s)
			Microtrips	N (%)	
$0 < V \leq 10$	3.55	24.47	45	13.05%	193
$10 < V \leq 20$	17.02	40.89	214	70.80%	919
$20 < V \leq 30$	20.60	40.57	18	16.15%	77

Table 3 Tram (Route3) Driving Characteristics

Velocity Ranges	V_{avg} (km/h)	V_{max} (km/h)	Number of Microtrips		T_{range} (s)
			Microtrips	N (%)	
$0 < V \leq 10$	3.39	29.56	75	14.42%	221
$10 < V \leq 20$	16.66	37.48	343	65.96%	893
$20 < V \leq 30$	21.38	43.58	102	19.62%	161

Table 4 Tram (Route4) Driving Characteristics

Velocity Ranges	V_{avg} (km/h)	V_{max} (km/h)	Number of Microtrips		T_{range} (s)
			Microtrips	N (%)	
$0 < V \leq 10$	4.12	22.36	161	31.20%	357
$10 < V \leq 20$	16.39	36.42	303	58.72%	513
$20 < V \leq 30$	20.62	35.94	52	10.08%	25

This material is reserved for educational use only, not allowed for commercial use.

Forbidden to modify the content, and cite the document when use.

(b) Inter-City (Shuttle Bus/Salaya Link) Driving Characteristics

Table 5 Shuttle Bus (S-Si) Driving Characteristics

Velocity Ranges	V_{avg} (km/h)	V_{max} (km/h)	Time spent(s)	Time spent (%)	T_{range} (s)
idle(V=0)			8800	18.62%	439
0<V≤10	3.91	35.96	1166	2.47%	58
10<V≤20	15.33	57.02	5662	11.98%	283
20<V≤30	24.05	71.78	6560	13.88%	327
30<V≤40	34.78	76.58	6153	13.02%	307
40<V≤50	45.09	81.84	9024	19.10%	450
50<V≤60	55.28	79.26	4143	8.77%	207
60<V≤70	64.27	80.15	4739	10.03%	236
70<V≤80	71.87	81.30	1004	2.12%	50

Table 6 Shuttle Bus (Si-S) Driving Characteristics

Velocity Ranges	V_{avg} (km/h)	V_{max} (km/h)	Time spent(s)	Time spent (%)	T_{range} (s)
idle(V=0)			23682	39.08%	1220
0<V≤10	3.04	34.18	2723	4.49%	140
10<V≤20	15.31	64.80	10235	16.89%	527
20<V≤30	24.87	74.89	6909	11.40%	356
30<V≤40	34.95	77.44	7159	11.81%	369
40<V≤50	44.77	74.57	4071	6.72%	210
50<V≤60	54.59	75.98	4547	7.50%	234
60<V≤70	63.90	78.37	1218	2.01%	63
70<V≤80	71.75	79.31	62	0.10%	3

Table 7 Shuttle Bus (S-W) Driving Characteristics

Velocity Ranges	V_{avg} (km/h)	V_{max} (km/h)	Time spent(s)	Time spent (%)	T_{range} (s)
idle(V=0)			45087	28.71%	1055
0<V≤10	3.11	32.07	6912	4.40%	162
10<V≤20	15.24	71.34	19683	12.53%	461
20<V≤30	24.37	73.74	27156	17.29%	635
30<V≤40	34.33	77.99	17022	10.84%	398
40<V≤50	44.33	79.37	11174	7.11%	261
50<V≤60	54.91	81.65	18449	11.75%	432
60<V≤70	64.69	80.04	8093	5.15%	189
70<V≤80	73.01	82.90	3493	2.22%	82

This material is reserved for educational use only, not allowed for commercial use.

Forbidden to modify the content, and cite the document when use.

Table 8 Shuttle Bus (W-S) Driving Characteristics

Velocity Ranges	V_{avg} (km/h)	V_{max} (km/h)	Time spent(s)	Time spent (%)	T_{range} (s)
idle(V=0)			48997	29.68%	1088
0<V≤10	3.13	39.27	10605	6.42%	236
10<V≤20	15.14	68.57	21889	13.26%	486
20<V≤30	24.36	77.64	21938	13.29%	487
30<V≤40	34.72	75.23	15925	9.65%	354
40<V≤50	44.93	81.09	21629	13.10%	480
50<V≤60	54.87	84.67	18770	11.37%	417
60<V≤70	63.86	83.00	4923	2.98%	109
70<V≤80	71.21	82.76	401	0.24%	9

Table 9 Salaya Link Driving Characteristics

Velocity Ranges	V_{avg} (km/h)	V_{max} (km/h)	Time spent(s)	Time spent (%)	T_{range} (s)
idle(V=0)			33846	20.49%	1007
0<V≤10	2.71	34.57	15067	9.12%	448
10<V≤20	15.13	72.97	16430	9.95%	489
20<V≤30	24.74	93.87	12046	7.29%	358
30<V≤40	35.44	85.00	13756	8.33%	409
40<V≤50	45.34	100.42	32481	19.66%	966
50<V≤60	54.97	94.19	23109	13.99%	688
60<V≤70	63.92	97.59	15942	9.65%	474
70<V≤80	74.38	93.74	2100	1.27%	62

(c) City (Shuttle Bus) Driving Characteristics

Table 10 Shuttle Bus (SiW) Driving Characteristics

Velocity Ranges	V_{avg} (km/h)	V_{max} (km/h)	Time spent(s)	Time spent (%)	T_{range} (s)
idle(V=0)			13642	38.66%	695
0<V≤10	3.28	36.74	3450	9.78%	176
10<V≤20	14.61	42.57	5668	16.06%	289
20<V≤30	24.43	53.26	7912	22.42%	403
30<V≤40	33.48	66.52	4342	12.31%	221
40<V≤50	41.10	53.66	271	0.77%	14

This material is reserved for educational use only, not allowed for commercial use.

Forbidden to modify the content, and cite the document when use.

Table 11 Shuttle Bus (WSi) Driving Characteristics

Velocity Ranges	V_{avg} (km/h)	V_{max} (km/h)	Time spent(s)	Time spent (%)	T_{range} (s)
idle(V=0)			13642	38.66%	695
0<V≤10	3.28	36.74	3450	9.78%	176
10<V≤20	14.61	42.57	5668	16.06%	289
20<V≤30	24.43	53.26	7912	22.42%	403
30<V≤40	33.48	66.52	4342	12.31%	221
40<V≤50	41.10	53.66	271	0.77%	14



This material is reserved for educational use only, not allowed for commercial use.

Forbidden to modify the content, and cite the document when use.

APPENDIX C PERCENTAGE ERROR OF GENERATED DRIVING CYCLE

a) Closed-Area (Tram)

Table 12 Percentage of time error in each speed range of generated driving cycle candidates (Tram: Route 1)

Error (%)	(1)	(2)	(3)	(4)	(5)	(6)	(7)	(8)	(9)	(10)
E₁	0.88	0.38	0.12	0.00	1.25	1.13	0.00	0.12	1.00	1.13
E₂	1.17	1.42	3.44	2.19	3.32	2.32	3.04	3.82	3.07	1.92
E₃	5.16	5.16	2.32	1.20	2.20	2.20	5.16	3.57	2.32	5.16
E	7.21	6.96	5.89	3.40	6.76	5.64	8.20	7.51	6.39	8.20

Table 13 Percentage of time error in each speed range of generated driving cycle candidates (Tram: Route 2)

Error (%)	(1)	(2)	(3)	(4)	(5)	(6)	(7)	(8)	(9)	(10)
E₁	1.61	1.19	1.53	0.52	1.53	0.27	1.61	1.36	1.36	1.61
E₂	0.05	0.38	1.48	7.62	1.04	1.23	3.50	2.74	3.82	1.30
E₃	3.09	6.50	2.63	0.23	3.09	0.23	0.40	0.23	0.23	2.63
E	4.75	8.07	5.63	8.37	5.66	1.72	5.51	4.33	5.41	5.54

Table 14 Percentage of time error in each speed range of generated driving cycle candidates (Tram: Route 3)

Error (%)	(1)	(2)	(3)	(4)	(5)	(6)	(7)	(8)	(9)	(10)
E₁	1.37	1.60	1.13	1.45	1.29	1.60	1.21	1.60	0.11	1.37
E₂	2.16	0.43	2.55	0.59	0.27	3.33	1.76	1.06	0.51	3.41
E₃	1.89	3.77	2.04	1.02	0.24	1.89	1.96	1.26	3.45	2.58
E	5.41	5.80	5.73	3.06	1.80	6.82	4.94	3.92	4.07	7.36

Table 15 Percentage of time error in each speed range of generated driving cycle candidates (Tram: Route 4)

Error (%)	(1)	(2)	(3)	(4)	(5)	(6)	(7)	(8)	(9)	(10)
E₁	2.19	0.15	2.86	0.63	3.31	1.41	3.76	3.20	3.09	2.08
E₂	3.98	3.87	3.20	3.53	2.30	2.42	3.20	1.52	4.43	5.43
E₃	2.79	2.79	2.79	2.79	2.79	2.79	2.79	2.79	2.79	2.79
E	8.97	6.81	8.85	6.96	8.41	6.62	9.75	7.51	10.31	10.31

This material is reserved for educational use only, not allowed for commercial use.

Forbidden to modify the content, and cite the document when use.

b) Inter-City (Shuttle Bus/Salaya Link) Driving Characteristics

Table 16 Percentage of time error in each speed range of generated driving cycle candidates (S-Si)

Error (%)	(1)	(2)	(3)	(4)	(5)	(6)	(7)	(8)	(9)	(10)
E₁	0.05	0.12	0.03	2.47	2.47	0.05	2.47	0.09	2.47	0.03
E₂	0.96	0.99	1.13	0.53	1.00	0.62	0.70	0.87	0.70	1.00
E₃	3.45	3.17	0.10	2.26	2.22	2.95	3.42	3.21	1.80	1.80
E₄	2.41	5.30	5.05	5.13	2.00	3.10	2.03	5.98	3.99	3.44
E₅	4.65	7.66	6.98	9.27	6.64	5.58	5.40	6.98	6.98	1.85
E₆	1.26	0.29	1.52	0.20	0.90	0.29	1.43	0.96	1.39	0.50
E₇	0.23	0.49	1.25	0.02	0.95	1.34	0.91	0.40	0.11	1.34
E₈	0.05	0.80	2.12	0.80	0.59	0.59	0.72	0.59	2.12	0.59
E	13.07	18.82	18.19	20.70	16.77	14.51	17.08	19.09	19.56	10.54

Table 17 Percentage of time error in each speed range of generated driving cycle candidates (Si-S)

Error (%)	(1)	(2)	(3)	(4)	(5)	(6)	(7)	(8)	(9)	(10)
E₁	0.09	0.09	0.14	0.14	0.12	0.02	0.17	0.02	0.11	0.14
E₂	0.97	0.30	0.33	1.08	1.17	0.56	1.01	0.60	1.58	1.45
E₃	0.80	2.18	1.70	2.98	1.70	2.50	2.37	3.07	0.96	0.51
E₄	2.24	1.41	5.76	0.16	1.48	3.59	1.89	1.53	0.80	0.83
E₅	0.92	0.92	4.52	1.02	4.99	2.23	3.29	2.23	2.33	0.74
E₆	1.00	0.66	1.32	0.89	0.69	1.34	0.44	1.23	1.17	0.33
E₇	0.14	0.12	0.02	0.38	0.28	0.31	0.01	0.38	0.01	0.01
E₈	0.10	0.10	0.10	0.10	0.10	0.10	0.10	0.10	0.10	0.10
E	6.26	5.78	13.90	6.73	10.53	10.65	9.27	9.16	7.06	4.12

Table 18 Percentage of time error in each speed range of generated driving cycle candidates (S-W)

Error (%)	(1)	(2)	(3)	(4)	(5)	(6)	(7)	(8)	(9)	(10)
E₁	0.13	0.05	0.13	0.21	0.05	0.05	0.16	0.06	0.21	0.12
E₂	0.20	0.48	0.97	0.31	1.21	0.15	1.02	0.91	1.08	1.08
E₃	4.94	1.02	4.01	3.03	2.19	1.97	2.43	0.83	4.94	4.85
E₄	4.14	2.40	3.90	0.97	4.47	4.31	4.47	0.50	4.06	1.84
E₅	0.47	7.11	5.24	6.43	5.97	5.78	0.61	6.16	0.70	0.70
E₆	2.33	1.86	0.77	0.93	2.21	2.10	1.87	0.18	0.70	1.94
E₇	0.13	0.59	0.96	0.66	0.64	0.15	0.77	0.96	0.70	0.64
E₈	0.16	0.10	0.26	0.70	0.26	0.35	0.37	0.29	0.16	0.40
E	12.50	13.61	16.24	13.26	17.01	14.86	11.70	9.89	12.53	11.56

This material is reserved for educational use only, not allowed for commercial use.

Forbidden to modify the content, and cite the document when use.

Table 19 Percentage of time error in each speed range of generated driving cycle candidates (W-S)

Error (%)	(1)	(2)	(3)	(4)	(5)	(6)	(7)	(8)	(9)	(10)
E₁	0.01	0.20	0.31	0.10	0.20	0.18	0.10	0.20	0.01	0.23
E₂	0.19	0.58	0.49	1.01	0.06	0.68	1.31	1.03	0.08	0.96
E₃	1.11	1.49	1.22	3.36	0.73	1.93	3.22	0.09	1.45	2.98
E₄	3.15	3.48	3.43	3.10	3.43	4.57	1.87	3.45	0.15	1.44
E₅	2.30	0.80	2.93	0.73	2.35	2.41	0.96	9.45	6.58	0.65
E₆	1.70	0.76	0.47	1.39	0.81	0.00	0.28	0.41	2.27	2.04
E₇	0.36	0.48	0.21	0.39	0.55	0.50	0.04	0.09	0.18	0.37
E₈	0.24	0.24	0.24	0.24	0.24	0.24	0.24	0.24	0.24	0.24
E	9.07	8.04	9.31	10.32	8.39	10.52	8.02	14.97	10.98	8.91

Table 20 Percentage of time error in each speed range of generated driving cycle candidates (Salaya Link)

Error (%)	(1)	(2)	(3)	(4)	(5)	(6)	(7)	(8)	(9)	(10)
E₁	0.29	0.33	0.26	0.14	0.35	0.43	0.40	0.43	0.45	0.43
E₂	0.57	0.81	0.70	0.06	0.39	0.44	0.49	0.25	0.61	0.79
E₃	0.07	2.19	7.29	0.72	1.07	1.82	1.76	2.10	0.07	7.29
E₄	1.82	0.45	2.86	0.51	1.46	4.01	2.59	2.76	0.07	2.19
E₅	12.13	8.49	8.04	9.00	12.15	10.32	7.52	9.75	9.33	8.11
E₆	0.17	1.19	0.60	0.58	1.42	1.64	0.78	2.49	1.60	1.03
E₇	1.39	0.23	1.70	1.80	1.90	1.32	1.57	1.70	1.84	0.39
E₈	0.09	0.09	0.05	0.05	0.21	0.05	0.56	0.38	0.38	0.11
E₉	0.25	0.25	0.25	0.25	0.25	0.25	0.25	0.25	0.25	0.25
E	16.80	14.04	21.75	13.12	19.20	20.29	15.92	20.12	14.59	20.60

c) City (Shuttle Bus)

Table 21 Percentage of time error in each speed range of generated driving cycle candidates (Si-W)

Error (%)	(1)	(2)	(3)	(4)	(5)	(6)	(7)	(8)	(9)	(10)
E₁	0.48	0.02	0.32	0.43	0.24	0.35	0.29	0.02	0.32	0.13
E₂	1.37	0.93	0.70	0.63	1.43	1.24	0.13	1.35	0.87	1.52
E₃	2.34	1.95	4.29	4.51	1.78	1.00	3.12	4.96	4.29	4.73
E₄	1.68	1.88	1.95	1.61	1.61	4.00	0.06	3.23	0.17	3.18
E₅	0.77	0.77	0.77	0.77	0.77	0.77	0.77	0.77	0.77	0.77
E	6.64	5.55	8.03	7.94	5.83	7.37	4.38	10.33	6.42	10.33

This material is reserved for educational use only, not allowed for commercial use.

Forbidden to modify the content, and cite the document when use.

Table 22 Percentage of time error in each speed range of generated driving cycle candidates (W-Si)

Error (%)	(1)	(2)	(3)	(4)	(5)	(6)	(7)	(8)	(9)	(10)
E₁	0.60	0.40	0.10	0.40	0.43	0.24	0.51	0.51	0.04	0.10
E₂	0.70	1.03	0.83	0.59	0.08	0.25	0.62	0.86	0.22	1.07
E₃	2.40	1.22	3.04	0.78	0.98	2.00	0.84	1.83	2.00	2.87
E₄	0.12	1.00	1.91	0.90	2.72	1.10	1.30	0.22	0.90	1.91
E₅	0.15	0.15	0.15	0.15	0.15	0.15	0.15	0.15	0.15	0.15
E	3.97	3.80	6.02	2.82	4.36	3.74	3.42	3.58	3.31	6.09



This material is reserved for educational use only, not allowed for commercial use.

Forbidden to modify the content, and cite the document when use.

**APPENDIX D PERCENTAGE ERROR OF REPRESENTATIVE DRIVING
CYCLE**

a) Closed-Area (Tram) Representative of Generated Driving Cycle

Table 23 Percentage of time error of Representative of Generated Driving Cycle

Close-Area	Candidate Number	Error in Speed Ranges			The sum of error
		0<V≤10	10<V≤20	20<V≤30	
Route 1	(4)	0	2.19	1.2	3.4
Route 2	(6)	0.27	1.23	0.23	1.72
Route 3	(5)	1.29	0.27	0.24	1.80
Route 4	(6)	1.41	2.42	2.79	6.62

b) Inter-City (Shuttle Bus/Salaya Link) Representative of Generated Driving Cycle

Table 24 Percentage of time error of Representative of Generated Driving Cycle of Shuttle Bus

Inter-City	Candidate Number	Error in Speed Ranges								sum
		0<V≤10	10<V≤20	20<V≤30	30<V≤40	40<V≤50	50<V≤60	60<V≤70	70<V≤80	
S-Si	(10)	0.03	1.00	1.80	3.44	1.85	0.50	1.34	0.59	10.54
Si-S	(10)	0.14	1.45	0.51	0.83	0.74	0.33	0.01	0.10	4.12
S-W	(8)	0.06	0.91	0.83	0.50	6.16	0.18	0.96	0.29	9.89
W-S	(7)	0.10	1.31	3.22	1.87	0.96	0.28	0.04	0.24	8.02

Table 25 Percentage of time error of Representative of Generated Driving Cycle of Salaya Link

Candidate Number	Error in Speed Ranges									sum
	0<V≤10	10<V≤20	20<V≤30	30<V≤40	40<V≤50	50<V≤60	60<V≤70	70<V≤80	80<V≤90	
(4)	0.14	0.06	0.72	0.51	9.00	0.58	1.80	0.05	0.25	13.12

c) City (Shuttle Bus/Salaya Link) Representative of Generated Driving Cycle

Table 26 Percentage of time error of Representative of Generated Driving Cycle of

Route	Candidate Number	Error in Speed Ranges								sum
		0<V≤10	10<V≤20	20<V≤30	30<V≤40	40<V≤50	50<V≤60	60<V≤70	70<V≤80	
Si-W	(7)	0.29	0.13	3.12	0.06	0.77	4.38	(7)	0.29	0.13
W-Si	(4)	0.40	0.59	0.78	0.90	0.15	2.82	(4)	0.40	0.59

This material is reserved for educational use only, not allowed for commercial use.

Forbidden to modify the content, and cite the document when use.

APPENDIX E TRAM STATION OPERATION

Table 27 Tram stop station names

No.	Tram Stop Station Names (Thai)	Tram Stop Station Names (English)
1	สถานีรถราง	Tram Station
2	อาคารอเนกประสงค์	Sport Building
3	สนามเปตอง	Petanque field
4	คณะสัตวแพทยศาสตร์	Faculty of veterinary science
5	วิทยาลัยศาสนศึกษา	College of religious studies
6	สถาบันฯเด็กและครอบครัว (สาย 3)	National Institute for child. (Line3)
7	สถาบันฯเด็กและครอบครัว (สาย 2)	National Institute for child. (Line2)
8	สนามฟุตบอล	Sport Field
9	หอพักพยาบาลรามธิบดี	Ramathibodi Dorm
10	อาคารชุดพักอาศัย (คอนโด)	Condominium
11	คณะศิลปศาสตร์	Faculty of Literal Arts
12	วิทยาลัยวิทยาศาสตร์การกีฬา	College of Sports Science
13	คณะกายภาพบำบัด	Faculty of Physical therapy
14	โรงเรียนพยาบาลรามาฯ (สาย 2)	Ramathibodi School of Nursing (Line 2)
15	โรงเรียนพยาบาลรามาฯ (สาย 3)	Ramathibodi School of Nursing (Line 3)
16	คณะสิ่งแวดล้อมและทรัพยากรศาสตร์	Faculty of Environment and Resource
17	แปลงผักปลอดสารพิษ	Organic Farm
18	คณะเทคโนโลยีการแพทย์	Faculty of Medical Technology
19	สถาบันวิจัยประชากรและสังคม	Institute for Pop. And Soc. Research
20	คณะวิศวกรรมศาสตร์ อาคาร 2	Faculty of Engineering building 2
21	หอสมุดและคลังความรู้ฯ	Library

This material is reserved for educational use only, not allowed for commercial use.

Forbidden to modify the content, and cite the document when use.

No.	Tram Stop Station Names (Thai)	Tram Stop Station Names (English)
22	คณะวิศวกรรมศาสตร์ อาคาร 3	Faculty of Engineering building 3
23	สถาบันชีววิทยาศาสตร์โมเลกุล	Institute of Molecular Bio.
24	ประตู 4	Gate 4
25	ประตู 3	Gate 3
26	สำนักงานอธิการบดี	Office of the President
27	วิทยาลัยนานาชาติ	International College
28	สถาบันสุขภาพอาเซียน	ASEAN Institute for Health
29	เรือนไทย	Thai House
30	คณะสังคมศาสตร์และมนุษยศาสตร์	Faculty of Social Science
31	วิทยาลัยดุริยางคศิลป์	College of Music
32	สถาบันวิจัยภาษาและวัฒนธรรมเอเชีย	Institute of Language
33	คณะวิทยาศาสตร์ 1-2	Faculty of Science 1-2
34	เรือนศิลปิน	Artists House
35	ลานจอดรถ 2 (สาย 3)	Parking 2 (Line 3)
36	ลานจอดรถ 2 (สาย 2)	Parking 2 (Line 2)
37	คณะวิทยาศาสตร์ 3-4	Faculty of Science 3-4
38	อุทยานธรรมชาติวิทยาสิริรุกขชาติ	Siri Rukhachati Nature Park
39	หอพัก 8-9 (หอใน)	Dorm 8-9
40	แหล่งนันทนาการทางน้ำ	Mu Lake
41	ลานจอดรถ 4	Parking 4
42	ศูนย์การเรียนรู้มหิดล	MLC

This material is reserved for educational use only, not allowed for commercial use.

Forbidden to modify the content, and cite the document when use.

Table 28 Tram stop station for each route

Tram 1

1	Tram Station
39	Dorm 8-9
37	Faculty of Science 3-4
33	Faculty of Science 1-2
30	Faculty of Social Science
27	IC
26	OP
24	Gate 4
22	Faculty of Engineering Building 3
21	Library
16	Faculty of Environment and Resource
12	College of Sports Science
2	Sport Building

Tram 4

42	MLC
37	Faculty of Science 3-4
34	Artists House
31	College of Music
35	Parking 2 (Line3)
33	Faculty of Science 1-2
30	Faculty of Social Science
27	IC
26	OP
28	ASEAN Institute for Health
29	Thai House
32	Institute of Language
36	Parking 2 (Line2)

Tram 2

1	Tram Station
39	Dorm 8-9
37	Faculty of Science 3-4
34	Artists House
31	College of Music
35	Parking 2 (Line3)
33	Faculty of Science 1-2
30	Faculty of Social Science
27	IC
26	OP
24	Gate 4
22	Faculty of Engineering building 3
20	Faculty of Engineering building 2
17	Organic Farm
15	Rama school of Nursing (Line3)
9	Ramathibodi Dorm
10	Condominium
6	National Institute for child. (Line3)
5	College of religious studies
3	Petanque field
2	Sport Building

Tram 3

1	Tram Station
42	Parking 5
40	MU Lake
41	Parking 4
4	Faculty of veterinary science
7	National Institute for child. (Line 3)
10	Condominium
8	Sport Field
11	Faculty of Literal Arts
13	Faculty of Physical therapy
14	Rama school of Nursing (Line2)
18	Faculty of Medical Technology
19	Institute for Pop. and Soc. Research
20	Institute of Molecular Bio.
25	Gate 3
26	OP
28	ASEAN Institute for Health
29	Thai House
32	Institute of Language
36	Parking 2 (Line2)
38	Siri Rukhachati Nature Park

This material is reserved for educational use only, not allowed for commercial use.

Forbidden to modify the content, and cite the document when use.

Table 29 Tram Operation Timetable

Route 1					Route 2-3					Route 4			
Tram	1	2	3	4	Tram	5	6	7	8	Tram	9	10	11
1	6:35	6:45	6:55	7:05	1	6:30	6:40	6:50	7:00	1	6:40	7:00	7:20
2	7:15	7:25	7:35	7:45	2	7:10	7:20	7:30	7:40	2	7:40	8:00	8:20
3	7:55	8:05	8:15	8:25	3	7:50	8:00	8:10	8:20	3	8:40	9:00	9:20
4	8:35	8:45	8:55	9:10	4	8:30	8:40	8:50	9:00	4	9:40	10:00	10:20
5	9:30	9:50	10:10	10:30	5	9:20	9:40	10:00	10:20	5	10:40	11:00	11:20
6	10:50	11:05	11:15	11:25	6	10:40	11:00	11:10	11:20	6	11:40	12:00	12:20
7	11:35	11:45	11:55	12:05	7	11:30	11:40	11:50	12:00	7	12:40	13:00	13:20
8	12:15	12:25	12:35	12:45	8	12:10	12:20	12:30	12:40	8	13:40	14:00	14:20
9	12:55	13:05	13:15	13:25	9	12:50	13:00	13:10	13:20	9	14:40	15:00	15:20
10	13:35	13:45	13:55	14:10	10	13:30	13:40	13:50	14:00	10	15:40	16:00	16:20
11	14:30	14:50	15:10	15:30	11	14:20	14:40	15:00	15:20	11	16:40	17:00	17:20
12	15:50	16:05	16:15	16:25	12	15:40	16:00	16:10	16:20	12	17:40	18:00	18:20
13	16:35	16:45	16:55	17:05	13	16:30	16:40	16:50	17:00	13	18:40	19:00	19:20
14	17:15	17:25	17:35	17:45	14	17:10	17:20	17:30	17:40	14	19:40	20:00	
15	17:55	18:05	18:15	18:25	15	17:50	18:00	18:10	18:20				
16	18:35	18:45	19:10	19:30	16	18:30	18:40	19:00	19:20				
17	19:50	20:10			17	19:40	20:00						

This material is reserved for educational use only, not allowed for commercial use.

Forbidden to modify the content, and cite the document when use.

APPENDIX F SHUTTLE BUS OPEARTION TIMETABLE

Table 30 Shuttle Bus Operation Timetable

Bus No. 1	5:45	7:30	9:30	10:15	11:00	15:05	16:15	17:15		
Station	Salaya	Wit	Salaya	Siriraj	Wit	Salaya	Wit	Siriraj	Salaya	
Bus No. 2	6:15	7:15	8:00	11:00	11:45	12:30	16:05	17:05	18:00	
Station	Salaya	Siriraj	Wit	Salaya	Siriraj	Wit	Salaya	Wit	Siriraj	Salaya
Bus No. 3	7:00	8:30	11:00	12:00	15:35	16:35	17:35	18:35		
Station	Salaya	Wit	Salaya	Wit	Salaya	Siriraj	Salaya	Wit	Salaya	
Bus No. 4	6:30	7:15	12:00	13:00	13:30	15:30	16:35	17:35		
Station	Siriraj	Wit	Salaya	Wit	Siriraj	Salaya	Wit	Salaya	Siriraj	
Bus No. 5	6:45	7:00	7:15	8:30	10:00	10:30	13:00	15:15	16:35	
Station	Wit	Pinklao	Siriraj	Salaya	Wit	Siriraj	Salaya	Wit	Salaya	Wit
Bus No. 6	7:00	7:15	7:45	10:00	12:00	12:45	14:30	15:45	17:05	
Station	Wit	Pinklao	Siriraj	Salaya	Wit	Siriraj	Salaya	Wit	Salaya	Wit
Bus No. 7	6:10	7:15	11:30	13:00	16:15	17:15				
Station	Salaya	Wit	Salaya	Wit	Salaya	Wit	Salaya			
Bus No. 8	6:00	7:30	10:00	11:30	13:10	14:00	16:45	17:45		
Station	Salaya	Siriraj	Salaya	Siriraj	Salaya	Siriraj	Salaya	Siriraj	Salaya	
Bus No. 9	6:40	9:00	13:35	16:45						
Station	Wit	Salaya	Wit	Salaya	Wit					

This material is reserved for educational use only, not allowed for commercial use.

Forbidden to modify the content, and cite the document when use.

Table 31 Collected shuttle bus driving data

		Inter-City				City	
		S-Wit	Wit-S	S-Si	Si-S	Si-Wit	Wit-Si
File No.	Cycle	45	47	20	18	20	19
	Route	92		38		39	
	InterCity/City	130					
Time (hr:min:s)	Time _{Cycle}	1:01:15	1:01:06	0:39:18	0:52:03	0:29:57	0:49:17
	Time _{Route}	1:01:01		0:45:26		0:39:06	
	Time _{Inter-city/city}	0:53:13					
Distance (km)	Avg Distance _{cycle}	24.614	23.672	21.10	16.875	6.616	7.449
	Avg Distance _{Route}	24.06		19.02		7.01	
	Distance _{sum}	1181.45	1159.94	422.01	303.75	132.33	134.08
	Distance _{all}	2341.39		725.76		266.41	
	3067.15						
Velocity (km/h)	Max Velocity _{Cycle}	85.44	93.78	85.90	84.26	67.06	60.56
	Max Velocity _{Route}	93.78		85.90		67.06	
	Max Velocity _{InterCity/City}	93.78					
	Mean Velocity _{Cycle}	26.27	24.85	31.99	19.30	13.80	9.79
	Mean Velocity _{Route}	25.56		25.64		11.79	
	Mean Velocity _{InterCity/City}	25.60					

This material is reserved for educational use only, not allowed for commercial use.

Forbidden to modify the content, and cite the document when use.

APPENDIX G SALAYA LINK OPERATED TIMETABLE

SALAYA LINK

Monday-Friday Timetable

Bang Wa - Salaya	Salaya - Bang Wa
06:45	06:00
07:10	06:30
07:30	07:00
08:35	08:00
09:35	09:00
11:35	11:00
12:30	12:00
13:30	13:00
14:30	14:00
16:10	15:30
17:10	16:30
18:10	17:30
18:40	18:00

Fare:

30

baht
one way
per person



Depart from Bang-Wa BTS Station at Exit No. 1-2 and walk about 20M to the Bus Stop.

Special Salaya Link Schedule for TPO's Concert

Friday: The Shuttle Bus (Salaya Link) will leave from Salaya to Bang Wa BTS

Saturday: The Shuttle Bus (Salaya Link) will leave from Bang Wa BTS Station to Salaya at 02:30 p.m., 03:00 p.m. and 03:20 p.m. and will leave from Salaya to Bang Wa BTS Station at 15 minutes after concert is finished.

Tel. 02-8002525 ext 1501
www.music.mahidol.ac.th/salayaLink



Figure 1 Salaya Link operation timetable

Table 32 Salaya Link bus operation timetable

Bus No	Time (Salaya Station)			
1	6:00	9:00	14:00	18:00
2	6:30	11:00	15:30	
3	7:00	12:00	16:30	
4	8:00	13:00	17:30	

This material is reserved for educational use only, not allowed for commercial use.

Forbidden to modify the content, and cite the document when use.

**APPENDIX H BATTERY AND CHARGING STATION COST FOR CAMPUS
BUS OPERATION**

Table 33 Battery and Charging Station Cost of Installed Battery 100 kWh

Installed Battery 100 kWh	Closed-Area		Inter-City		City	
	Traction	Total	Traction	Total	Traction	Total
$E_{required}$ (kWh)	49	116	132	243	56	183
No. of chargers	1	1	2	2	1	1
Charger Unit Price (THB)	1,661,651	1,661,651	3,323,301	3,323,301	1,661,651	1,661,651
Installation Battery Price (THB)	2,096,512					
Total Cost	3,758,163	3,758,163	5,419,813	5,419,813	3,758,163	3,758,163

Table 34 Battery and Charging Station Cost of Installed Battery 150 kWh

Installed Battery 100 kWh	Closed-Area		Inter-City		City	
	Traction	Total	Traction	Total	Traction	Total
$E_{required}$ (kWh)	49	116	132	243	56	183
No. of chargers	1	1	2	2	1	1
Charger Unit Price (THB)	1,661,651	1,661,651	3,323,301	3,323,301	1,661,651	1,661,651
Installation Battery Price (THB)	3,284,536					
Total Cost	4,946,186	4,946,186	6,607,837	6,607,837	4,946,186	4,946,186

Table 35 Battery and Charging Station Cost of Installed Battery 200 kWh

Installed Battery 100 kWh	Closed-Area		Inter-City		City	
	Traction	Total	Traction	Total	Traction	Total
$E_{required}$ (kWh)	49	116	132	243	56	183
No. of chargers	1	1	2	2	1	1
Charger Unit Price (THB)	1,661,651	1,661,651	3,323,301	3,323,301	1,661,651	1,661,651
Installation Battery Price (THB)	4,379,381					
Total Cost	6,041,032	6,041,032	7,702,682	7,702,682	6,041,032	6,041,032

This material is reserved for educational use only, not allowed for commercial use.

Forbidden to modify the content, and cite the document when use.

**APPENDIX I BATTERY AND CHARGING STATION COST FOR FIX
VEHICLE RANGE**

Table 36 Battery Size 100 kWh and Charging Station Cost for Vehicle Range 50 km

Installed Battery 100 kWh	Closed-Area		Inter-City		City	
	Traction	Total	Traction	Total	Traction	Total
<i>E_{required}</i> (kWh)	26	61	35	64	29	97
No. of charger	1	1	1	1	1	2
Charger Unit Price (THB)	1,661,651	1,661,651	1,661,651	1,661,651	1,661,651	3,323,301
Installation Battery Price (THB)			2,189,691			
Total Cost	3,851,341	3,851,341	3,851,341	3,851,341	3,851,341	5,512,992

Table 37 Battery Size 100 kWh and Charging Station Cost for Vehicle Range 100 km

Installed Battery 100 kWh	Closed-Area		Inter-City		City	
	Traction	Total	Traction	Total	Traction	Total
<i>E_{required}</i> (kWh)	52	122	69	128	58	193
No. of charger	1	2	1	2	1	3
Charger Unit Price (THB)	1,661,651	3,323,301	1,661,651	3,323,301	1,661,651	4,984,952
Installation Battery Price (THB)			2,189,691			
Total Cost	3,851,341	5,512,992	3,851,341	5,512,992	3,851,341	7,174,642

Table 38 Battery Size 100 kWh and Charging Station Cost for Vehicle Range 150 km

Installed Battery 100 kWh	Closed-Area		Inter-City		City	
	Traction	Total	Traction	Total	Traction	Total
<i>E_{required}</i> (kWh)	78	183	104	192	88	290
No. of charger	1	2	2	3	1	4
Charger Unit Price (THB)	1,661,651	3,323,301	3,323,301	4,984,952	1,661,651	6,646,602
Installation Battery Price (THB)			2,189,691			
Total Cost	3,851,341	5,512,992	5,512,992	7,174,642	3,851,341	8,836,293

Table 39 Battery Size 100 kWh and Charging Station Cost for Vehicle Range 200 km

Installed Battery 100 kWh	Closed-Area		Inter-City		City	
	Traction	Total	Traction	Total	Traction	Total
<i>E_{required}</i> (kWh)	104	245	139	256	117	387
No. of charger	2	3	2	3	2	5
Charger Unit Price (THB)	3,323,301	4,984,952	3,323,301	4,984,952	3,323,301	8,308,253
Installation Battery Price (THB)			2,189,691			
Total Cost	5,512,992	7,174,642	5,512,992	7,174,642	5,512,992	10,497,944

This material is reserved for educational and research purposes. All rights reserved. No part of this document may be reproduced, stored in a retrieval system, or transmitted in any form or by any means, electronic, mechanical, photocopying, recording, or by any information storage and retrieval system, without the prior written permission of the copyright owner.

Forbidden to modify the content, and cite the document when use.

Table 40 Battery Size 150 kWh and Charging Station Cost for Vehicle Range 50 km

Installed Battery 150 kWh	Closed-Area		Inter-City		City	
	Traction	Total	Traction	Total	Traction	Total
<i>E_{required}</i> (kWh)	26	61	35	64	29	97
No. of charger	1	1	1	1	1	1
Charger Unit Price (THB)	1,661,651	1,661,651	1,661,651	1,661,651	1,661,651	1,661,651
Installation Battery Price (THB)	3,284,536					
Total Cost	4,946,186	4,946,186	4,946,186	4,946,186	4,946,186	4,946,186

Table 41 Battery Size 150 kWh and Charging Station Cost for Vehicle Range 100 km

Installed Battery 150 kWh	Closed-Area		Inter-City		City	
	Traction	Total	Traction	Total	Traction	Total
<i>E_{required}</i> (kWh)	52	122	69	128	58	193
No. of charger	1	1	1	1	1	2
Charger Unit Price (THB)	1,661,651	1,661,651	1,661,651	1,661,651	1,661,651	3,323,301
Installation Battery Price (THB)	3,284,536					
Total Cost	4,946,186	4,946,186	4,946,186	4,946,186	4,946,186	6,607,837

Table 42 Battery Size 150 kWh and Charging Station Cost for Vehicle Range 150 km

Installed Battery 150 kWh	Closed-Area		Inter-City		City	
	Traction	Total	Traction	Total	Traction	Total
<i>E_{required}</i> (kWh)	78	183	104	192	88	290
No. of charger	1	2	1	2	1	3
Charger Unit Price (THB)	1,661,651	3,323,301	1,661,651	3,323,301	1,661,651	4,984,952
Installation Battery Price (THB)	3,284,536					
Total Cost	4,946,186	6,607,837	4,946,186	6,607,837	4,946,186	8,269,488

Table 43 Battery Size 150 kWh and Charging Station Cost for Vehicle Range 200 km

Installed Battery 150 kWh	Closed-Area		Inter-City		City	
	Traction	Total	Traction	Total	Traction	Total
<i>E_{required}</i> (kWh)	104	245	139	256	117	387
No. of charger	1	2	1	2	1	3
Charger Unit Price (THB)	1,661,651	3,323,301	1,661,651	3,323,301	1,661,651	4,984,952
Installation Battery Price (THB)	3,284,536					
Total Cost	4,946,186	6,607,837	4,946,186	6,607,837	4,946,186	8,269,488

This material is reserved for educational use only, not allowed for commercial use.

Forbidden to modify the content, and cite the document when use.

Table 44 Battery Size 200 kWh and Charging Station Cost for Vehicle Range 50 km

Installed Battery 200 kWh	Closed-Area		Inter-City		City	
	Traction	Total	Traction	Total	Traction	Total
<i>E_{required}</i> (kWh)	26	61	35	64	29	97
No. of charger	1	1	1	1	1	1
Charger Unit Price (THB)	1,661,651	1,661,651	1,661,651	1,661,651	1,661,651	1,661,651
Installation Battery Price (THB)	4,379,381					
Total Cost	6,041,032	6,041,032	6,041,032	6,041,032	6,041,032	6,041,032

Table 45 Battery Size 200 kWh and Charging Station Cost for Vehicle Range 100 km

Installed Battery 200 kWh	Closed-Area		Inter-City		City	
	Traction	Total	Traction	Total	Traction	Total
<i>E_{required}</i> (kWh)	52	122	69	128	58	193
No. of charger	1	1	1	1	1	2
Charger Unit Price (THB)	1,661,651	1,661,651	1,661,651	1,661,651	1,661,651	3,323,301
Installation Battery Price (THB)	4,379,381					
Total Cost	6,041,032	6,041,032	6,041,032	6,041,032	6,041,032	7,702,682

Table 46 Battery Size 200 kWh and Charging Station Cost for Vehicle Range 150 km

Installed Battery 200 kWh	Closed-Area		Inter-City		City	
	Traction	Total	Traction	Total	Traction	Total
<i>E_{required}</i> (kWh)	78	183	104	192	88	290
No. of charger	1	1	1	2	1	2
Charger Unit Price (THB)	1,661,651	1,661,651	1,661,651	3,323,301	1,661,651	3,323,301
Installation Battery Price (THB)	4,379,381					
Total Cost	6,041,032	6,041,032	6,041,032	7,702,682	6,041,032	7,702,682

Table 47 Battery Size 200 kWh and Charging Station Cost for Vehicle Range 200 km

Installed Battery 200 kWh	Closed-Area		Inter-City		City	
	Traction	Total	Traction	Total	Traction	Total
<i>E_{required}</i> (kWh)	104	245	139	256	117	387
No. of charger	1	2	1	2	1	3
Charger Unit Price (THB)	1,661,651	3,323,301	1,661,651	3,323,301	1,661,651	4,984,952
Installation Battery Price (THB)	4,379,381					
Total Cost	6,041,032	7,702,682	6,041,032	7,702,682	6,041,032	9,364,333

This material is reserved for educational use only, not allowed for commercial use.

Forbidden to modify the content, and cite the document when use.

AUTHOR BIOGRAPHY

Author: Miss Bongkotchaporn Duangsrikaew
Degree: Master of Engineering
Date of Graduation: August 8th, 2018
Date of Birth: November 16th, 1992
Place of Birth: Bangkok, Thailand

Undergraduate and Graduate Education:

Master of Engineering in Automotive Engineering,
King Mongkut's Institute of Technology Ladkrabang, Bangkok, 2018

Bachelor's degree in Survey Engineering, Chulalongkorn University, Bangkok, 2014

Major: Automotive Engineering

Presentations and Publications:

- [1] Bongkotchaporn Duangsrikaew, Jiravan Mongkoltanatas, Preechar Karin, Hanamura Katsunori, Chi-na Benyajati, "Energy Consumption Analysis for Electric Campus Tram design based on Real University Driving Cycle Pattern in Thailand", 2017, The 8th Thai Society of Mechanical Engineers, International Conference on Mechanical Engineering, December 12-15, 2017, Arnoma Grand Hotel, Bangkok, Thailand.
- [2] Bongkotchaporn Duangsrikaew, Jiravan Mongkoltanatas, Preechar Karin, Hanamura Katsunori, Chi-na Benyajati, "Energy Consumption Analysis for Electric Campus Tram and Shuttle Bus based on Real-World Driving Pattern in Thailand", 2018, JSAE Annual Spring Congress, May 23-25, 2018, Yokohama Japan.
- [3] Bongkotchaporn Duangsrikaew, Jiravan Mongkoltanatas, Preechar Karin, Hanamura Katsunori, Chi-na Benyajati, "Battery Sizing for Electric Vehicles based on Real Driving Pattern in Thailand", The 31st International Electric Vehicle Symposium & Exhibition & International Electric Vehicle Technology Conference 2018, Sept.30 - Oct.3, Kobe Convention Center, Japan.

This material is reserved for educational use only, not allowed for commercial use.

Forbidden to modify the content, and cite the document when use.