

# Air Flow's Enhancement in Impingement Tunnel

Thanarak Kosalwitr Kiatfa Tangchaichit

Department of Mechanical Engineering, Faculty of Engineering,

Khon Kaen University, Khon Kaen, 40002, Thailand.

## Abstract

The air impingement technology has been used in frozen food industry for decades to achieve rapid freezing that can freeze the food with better texture than conventional freezing. In the freezing process the determined freezing time must be selected from the longest time that frozen food temperature is reached -18°C. To minimize the freezing time variation from different locations along the conveyor belt's width, the pressured chamber was investigated using computational fluid dynamics. The SST,  $k-\omega$  turbulence model was used in this study. Changing the geometry in the pressured chamber with baffle plates impacted the exit velocity from impingement nozzles, which can deliver better average exit velocity and variation. The mixed model of existing with 2 of P532.5 for 3 chambers impingement tunnel freezer gives a 22.2% better minimum exit velocity than the existing model, and a variation of exit velocity 2.53 times better than the existing model.

**Keywords :** Impingement freezer, Computational Fluid Dynamic (CFD), SST, Pressured chamber, Impingement nozzle, Exit velocity, Vortexes.

## 1. Introduction

The freezing rate is one of the important factors to the quality of the frozen food. A slow freezing rate creates large ice crystals, and damages the food cellular structures, which produce bad food texture [1-4]. There are several techniques to achieve rapid freezing with smaller ice crystals such as microwave freezing [5], ultrasonic freezing [6-

11], impingement freezing etc. The air impingement technology has been used in various processes, such as the drying process of textile, the annealing process of glass [12], and the food freezing process, to achieve better freezing rates by directing the high freezing air velocity against the food surface to break the insulating boundary layer which surrounds the product [13,14].

In frozen food processing, the freezing time depends on many factors which are the characteristic of food such as thermal conductivity, shape etc., freezing air temperature and freezing air velocity [15]. In the normal practice of operation, freezing times for tunnel freezer are determined by the slowest freezing rate along the conveyor belt's width to ensure the core temperature of every piece of the frozen food is under  $-18^{\circ}\text{C}$ .

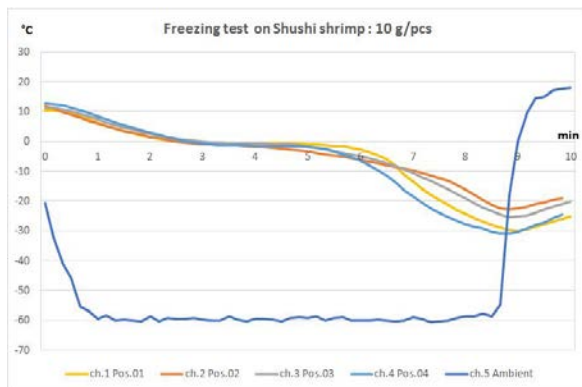

**Fig. 1** Shushi shrimp freezing time.

In the example of the Shushi shrimp freezing process, the slowest freezing time is 8 minutes and 10 seconds, while the fastest freezing time is 7 minutes, as shown in Fig. 1. The 8 minute and 10 second freezing time gives processing losses which are the throughput loss and quality loss due to the product over-freezing at  $-30^{\circ}\text{C}$ .

There are many alternatives to improve impingement freezer freezing performance such as the nozzle design [17-19], the efficiency of fan, the pressured chamber etc. The good pressured chamber design generates high exit velocity in impingement tunnel freezer which

can be between 15-60 m/s. The numerical simulations are widely used to analyze the heat transfer rate in the air impingement technique. The exit velocity depends on many factors such as the nozzle design [16], the pressured chamber, type of fan etc. which impact the heat transfer rate.

Changing geometry in the pressured chamber is the proper alternative for a quick solution without any big modifications in the impingement tunnel freezer. Therefore, changing the geometry of the pressured chamber is the focus area in this study, and can be done by air guide vane, air entry channel [20], or air baffle plate [20-21]. Introducing the baffle plate in the pressured chamber is the scope of this study.

## 2. Material and Method

In this study, the impingement tunnel freezer contains with 3 pressured chambers with low freezing air temperature from  $-35$  to  $-60^{\circ}\text{C}$  as shown in Fig. 2.

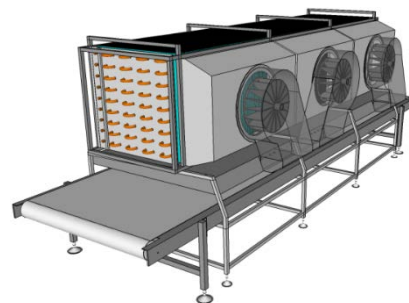

**Fig. 2** The single module of impingement freezer.

## 2.1 Numerical Analysis

The numerical simulations are carried out using the commercial CFD ANSYS version 14. The air flow, exit velocity and turbulence filed use the Shear-Stress Transport (SST),  $k-\omega$  turbulence model to the analysis which give an acceptable prediction [21] in the pressured chamber as shown in Fig. 3. Boundary of chamber was set as a stationary wall.

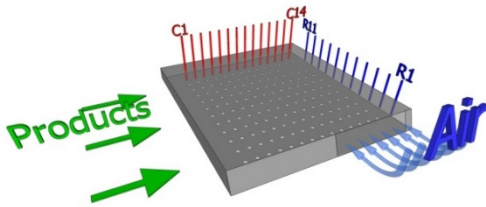

**Fig. 3** Pressured chamber

The turbulence model was used in this research. Incompressible fluid and constant density was also used in this simulation. Mass conservation and momentum conservation equations, as following, were used.

$$\frac{\partial u_i}{\partial x_i} = 0 \quad (1)$$

$$\frac{\partial \rho u_i}{\partial t} + \frac{\partial u_j \rho u_i}{\partial x_j} = -\frac{\partial p}{\partial x_i} + \frac{\partial}{\partial x_j} \mu \left( \frac{\partial u_i}{\partial x_j} + \frac{\partial u_j}{\partial x_i} \right) - \rho g_i \beta (T - T_o) \quad (2)$$

- $x_i$  Coordination (m)
- $u_i$  Velocity of flow in  $x_i$ -direction (m/s)
- $t$  Time (s)
- $\rho$  Density of fluid ( $\text{kg/m}^3$ )
- $p$  Pressure of a fluid (Pa)

- $\mu$  Viscosity (Pa-s)
- $g_i$  Gravity ( $\text{m/s}^2$ )
- $\beta$  Coefficient of volume expansion ( $1/\text{K}$ )
- $T$  Temperature of a fluid (K)
- $T_o$  Reference temperature of a fluid (K)

Four type of elements were used to calculate and compared with the experiment results. Tetrahedral element was chosen to use in this research. Because it gave the minimum error when compared with the experiment result and it's also take less time to calculate.

There are two types of baffle plates applied to the analysis as shown in Fig. 4. The baffle plate dimensions are 433 mm with 20 mm thickness, while the perforated baffle plate has 10 holes with 20 mm diameter. The vertical gap between baffle plate and the pressured chamber is 10 mm.

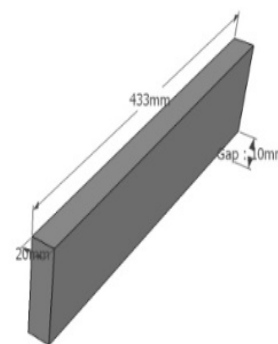

(a)

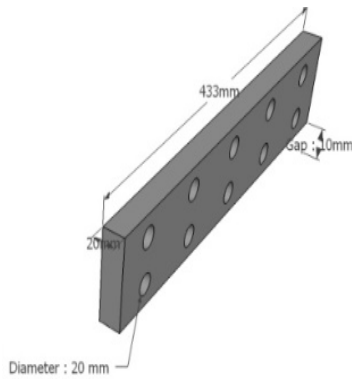

(b)

**Fig. 4** Baffle Plate (a) Baffle Plate  
(b) Perforated Plate

The pressured chamber has 154 nozzles with 20mm diameter. There are 11 nozzles along conveyor's belt width (R1-R11) and 14 nozzles on another side (C1-C14). The five of baffle plate models are P192.5, P227.5, P362.5, P447.5 and P532.5 and five of perforate plate models which are PP192.5, PP227.5, PP362.5, PP447.5 and PP532.5. The numbers of all models are the distance from entrance edge as shown in Fig. 5.

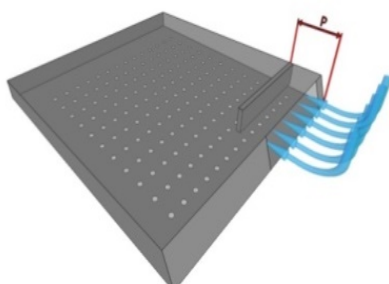

(a)

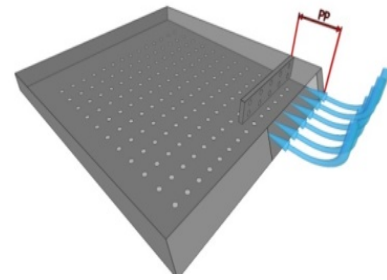

(b)

**Fig. 5** Pressured chamber with baffle Plate (a) P (b) PP

Property of air used in this research shows in Table 1.

**Table 1** Property of Air

Property of Air	
Temperature	-15.0 C
Density	1.37073 kg/m <sup>3</sup>
Viscosity	1.6472 x 10 <sup>-5</sup> kg/m s

## 2.2. Tools and equipment

The TESTO 545 portable data logger was used to measure the average exit air velocity, as shown in Fig. 6.

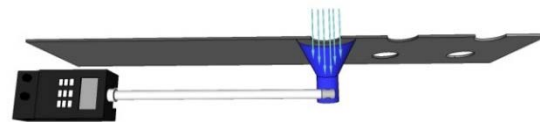
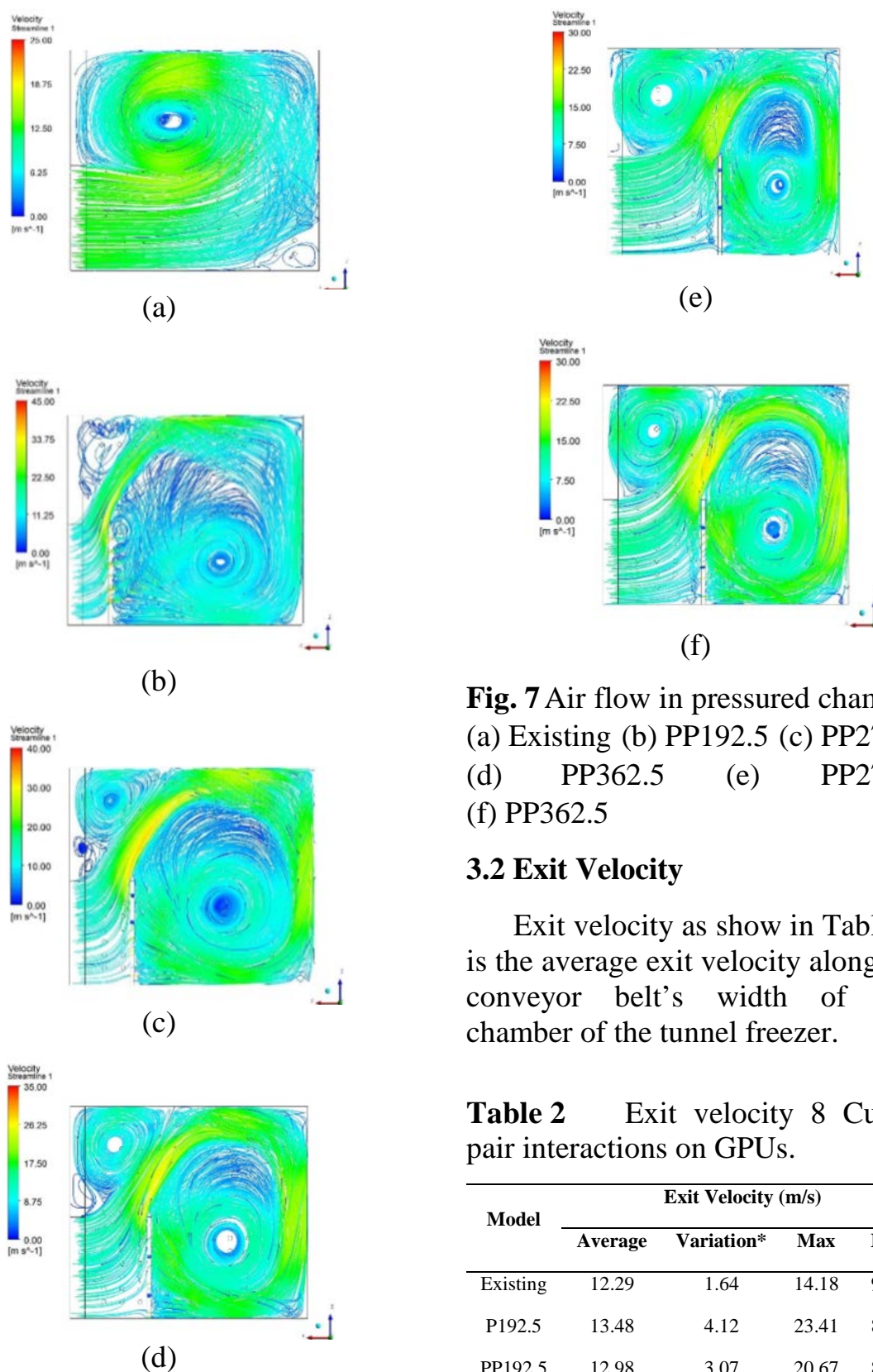

**Fig. 6** Exit air velocity measuring device.

## 3. Results

### 3.1. Air Flow

All simulation models of the air flow in pressured chambers show the vortices in different locations in the pressured chamber, as shown in Fig. 7 and Fig. 8.



**Fig. 7** Air flow in pressured chamber (a) Existing (b) PP192.5 (c) PP277.5 (d) PP362.5 (e) PP277.5 (f) PP362.5

### 3.2 Exit Velocity

Exit velocity as show in Table 2, is the average exit velocity along the conveyor belt's width of one chamber of the tunnel freezer.

**Table 2** Exit velocity 8 Cutoff pair interactions on GPUs.

Model	Exit Velocity (m/s)			
	Average	Variation*	Max	Min
Existing	12.29	1.64	14.18	9.59
P192.5	13.48	4.12	23.41	8.92
PP192.5	12.98	3.07	20.67	8.45
P277.5	13.38	3.51	20.02	10.07
PP277.5	13.44	3.51	20.03	9.96
P362.5	13.21	3.04	17.54	9.45

PP362.5	13.07	3.07	17.61	9.38
P447.5	13.21	3.04	17.54	9.45
PP447.5	13.06	2.36	16.70	9.80
P532.5	12.78	1.51	15.15	10.67
PP532.5	12.83	1.64	15.34	10.50

Remark: \*Variation: Calculated by standard deviation of average exit velocity

All models give the average exit velocity higher than the existing model. However, only P532.5 and PP532.5 models give lower variation of exit velocity than the existing model.

#### 4. Discussion

All simulation models have a vortex effect, which negatively impacts the variations of exit velocity. The mixed model for 3 chambers of this freezer is presented to minimize the variation of freezing time along the conveyor belt's width as shown in Table 3.

**Table 3** Exit velocity for 3 pressured chambers.

Model	Exit Velocity (m/s)			
	Average	Variation	Max	Min
3 Existing	12.29	1.64	14.18	9.59
Existing + 2 of P532.5	12.62	0.65	13.44	11.72
Existing + 2 of PP532.5	12.65	0.71	13.46	11.61

The two mixed models, as shown in Table 3, can deliver better minimum exit velocity and variation.

#### 5. Conclusion

The negative impact from vortexes could not be avoided in all simulation models. However, using the baffle plate to change the geometry of the pressured chamber gives positive results in the mixed models as shown in Table 3. The mixed model of existing with 2 of P532.5 for 3 chambers impingement tunnel freezer gives a 22.2% better minimum exit velocity than the existing model, and a variation of exit velocity 2.53 times better than the existing model.

#### 6. Acknowledgements

The authors would like to express their gratitude to Charoen Pokphand Foods Public Company Limited (Chia Tai Group) and Khon Kaen University for all supports to this study.

#### 7. References

- [1] S. Ahmad, P. Yaghmaee, T. Durance, "Optimization of dehydration of lactobacillus salivarius using radiant energy vacuum", Food and Bioprocess Technology, 1-9, 2010.
- [2] A. Delgado, L. Zheng, D. W. Sun, "Influence of ultrasound on freezing rate of immersion-frozen apples", Food and Bioprocess Technology, Vol. 2, 263-270, 2009.

- [3] F. Streit, G. Corrieu, B. C. eal, "Effect of centrifugation conditions on the cryotolerance of lactobacillus bulgaricus cfl1", Food and Bioprocess Technology, Vol. 3, 36-42, 2010.
- [4] V. Soto, R. Borquez., "Impingement jet freezing of bio material", Food Control, Vol. 12, 515-522, 2001.
- [5] T. H. Jackson, A. Ungan, J. K. Critser, and D. Y. Gao, "Novel microwave technology for cryo-preservation of biomaterials by suppression of apparent ice formation", Cryobiology, Vol. 34, 363-372, 1997.
- [6] T. Inada, X. Zhang, A. Yabe, and Y. Kozawa, "Active control of phase change from super cooled water to ice by ultrasonic vibration 1. Control of freezing temperature", International Journal of Heat and Mass Transfer, Vol. 44, 4523-4531. 2001.
- [7] M. Saclier, R. Peczalski, J. Andrieu, "Effect of ultrasonically induced nucleation on ice crystals' size and shape during freezing in vials", Chemical Engineering Science, Vol. 65, 3064-3071, 2010.
- [8] R. Chow, R. Blindt, R. Chivers, and M. Povey, "The sono crystallisation of ice in sucrose solutions: primary & secondary nucleation", Ultrasonics, Vol. 41, 595-604, 2003.
- [9] R. Chow, R. Blindt, A. Kamp, P. Grocutt, and R. Chivers, "The microscopic visualisation of the sonocrystallisation of ice using a novel ultrasonic cold stage", Ultrasonics Sonochemistry, Vol. 11, 245-250, 2004.
- [10] G. Rucroft, D. Hipkiss, T. Ly, N. Maxted, and P. W. Cains, "Sonocrystallization: the use of ultrasound for improved industrial crystallization", Organic Process Research & Development, Vol. 9, 923-932, 2005.
- [11] L. Zheng, D. W. Sun, "Ultrasonic assistance of food freezing", In D.-W. Sun (Ed.), Emerging technologies for food processing. Amsterdam; London : Elsevier Academic Press, 2005.
- [12] Yang Geunyoung, Choi Man soo, Sik Lee Joon, "An experimental study of slot jet impingement cooling on concave surface: effects of the nozzle configuration and curvature", International Journal of Heat Transfer, Vol. 42, 2199-2209, 1999.

- [13] Salvadori O. Viviana, Mascheroni H. Rodolfo, "Analysis of impingement freezers performance", *Journal of Food Engineering*, Vol.54, 133–140, 2002.
- [14] Anderson A. Brent, Paul Singh R., "Effective heat transfer coefficient measurement during air impingement thawing using an inverse method", *International Journal of Refrigeration*, Vol. 29, 281-293, 2006.
- [15] Huan Zhongjie, He a Shaoshu, Ma Yitai, "Numerical simulation and analysis for quick-frozen food processing", *Journal of Food Engineering*, Vol. 60, 267-273, 2003.
- [16] Arnab Sarkar, R.Paul Singh, "Air Impingement technology for food processing: visualization studies", *Lebensm.Wiss. u.Technol*, Vol. 37, 873-879, 2004.
- [17] A. Sarkar, N. Nitin, M. V. Karwe, and R. P. Singh, "Fluid Flow and Heat Transfer in Air Jet Impingement in Food Processing", *Journal of food science*, Vol. 69, No. 4, 113-122, 2004.
- [18] N. K. Chougule, G. V. Parishwad, P. R. Gore, S. Pagnis, and S. N. Sapali, "CFD Analysis of Multi-jet Air Impingement on Flat Plate", *Proceeding of the world Congress on Engineering*, Vol. 3, ISSN: 2078-0966, 2011.
- [19] B. Dahbia, M. Amina, in the Ninth International Conference on Computational Fluid Dynamics (ICCFD9) Istanbul, Turkey, July 11-15, 2016.
- [20] T. Kosalwitr, K. Tangchaichit, "Freezing time of the impingement tunnel freezer enhancement", *KKU ENGINEERING JOURNAL*, Vol. 43, No. 3, 409-411, 2016.
- [21] D. Prashata, D. Sandip, "Effect of baffle size, perforate and orientation on internal heat transfer enhancement", *International Journal of Heat and Mass Transfer*, Vol. 41, 3005-3013, 1998.
- [22] E.Mehmet, C. Sinan, Z. Muammer, "Experimental Investigation of Heat transfer in a Rectangular Channel with Perforate Ribs", *The Online Journal of Science and Technology*, Vol. 5, Issue 3, 37-44, 2015.