

# PI Controller Optimization for Indirect Current Control for Single-Phase Shunt Active Filter

Kanapot Yodmanee    Wanchak Lenwari

Department of Control System and Instrumentation Engineering  
King Mongkut's University of Technology Thonburi, Bangkok, Thailand

## Abstract

The conventional current control of shunt active filters deals with the design of controller in order to track harmonic reference currents with the lowest possible error. An indirect current control appears to be an alternative approach for active filter control. This method focuses on the control of reference source current rather than harmonic current. As a result, a simple Proportional–integral (PI) controller can be used in the control design which is one of the main benefits. However, to obtain suitable controller parameter they require considerable design effort. In this paper, a new design of PI controller for indirect current control for a single-phase shunt active filter has been proposed. Optimized controller parameters are obtained through the use of Genetic Algorithms (GA). Reference source current is derived based on a single-phase synchronous d-q reference frame. Simulation results are presented to validate the proposed design method.

**Keywords:** Single phase shunt active filter, Indirect current control, PI(Proportional-Integral), GA(Genetic Algorithms)

## 1. Introduction

Nowadays, computers, communication devices and automation devices are examples of loads which widely use. By using these devices, harmonic current is generated while reactive power is consumed i.e. a rectifier for AC-DC power conversion. These nonlinear loads cause voltage distortion and even harmonic problems. For the single-phase system to remove harmonics generated from nonlinear loads, a single-phase active power filter is one of very effective devices [1-2].

Active power filtering applications widely use synchronous frame based strategies [3]. The control design in this synchronous d-q frame of reference has the advantage that fundamental quantities appear as dc values. These strategies require transformations. Another popular method is to use instantaneous active and reactive power theory or (simply p-q theory) which originally applies to a three-phase active

filtering [4]. However the original park transformation and p-q theory cannot be used directly for the single-phase system. The three-phase p-q theory can be applied to use with single-phase system by the addition of an imaginary variable which is an original signal of voltage or current shifted by 90 degree that is utilized to single-phase synchronous d-q reference [5].

The current control systems of shunt active filters can be divided into two main groups, direct current control and indirect current control. In the direct current control the reference signal is harmonic current. The controllers must be designed to inject harmonic currents and match reference currents with minimum error [6-7]. The difficulty in the design is the tracking problem in particular for controlling higher order harmonics which is not straightforward to design the current controller and achieve zero steady-state error. While the indirect current methods focus on the

control of reference source current. Some researchers have proposed indirect current control methods [8-10] and found that they can give satisfactory or better performance and some works number of sensors can be reduced.

However, when designed the current controller based on indirect method it becomes more difficult because the filter inductor cannot be directly used as a plant transfer function. In this paper, to overcome this problem, optimization algorithm by GA has been developed for the tuning of proportional integral (PI) controller based on the indirect current control strategy for a single-phase shunt active filter. To obtain high performance control response optimized values of controller parameters are required. The design procedure and the principle of the proposed control method are proposed and discussed. Simulation results are presented to confirm the effectiveness, accuracy, and validity of the proposed strategy.

## 2. Single-Phase Shunt Active Filter

### 2.1 Conventional Current Control

The scheme of a single-phase shunt active filter with the connection to the main supply and nonlinear load is shown in Fig. 1. Without the filter connected to the network, the supply current ( $i_S$ ) is contaminated by the harmonic currents.

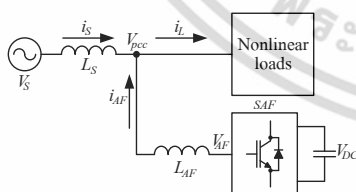

**Fig.1** The conventional scheme of a single-phase shunt active filter

The SAF acts as an ideal controlled current source and injects antiphase harmonic currents, having the same amplitude but the phase is inversed, to cancel those drawn by nonlinear loads. The filter output voltage ( $V_{AF}$ ) is controlled with respect to the measured voltage at the point of common coupling ( $V_{pcc}$ ), to force the active filter

current ( $i_{AF}$ ) to match its demanded (reference) values ( $i_{AF}^*$ ). Basically, the SAF performance can be assessed by two aspects, the reference current generation method used to obtain the harmonic demanded current and the control system strategy used to control the real current to precisely track the demanded harmonic current obtained from the reference current generation method.

### 2.2 Nonlinear load current

In steady-state condition, the nonlinear load current in a single-phase system is a periodic signal which contains only odd harmonics as a series of sinusoidal waveforms which have been summed together. By using a Fourier series expansion, a nonlinear load current is given as:

$$i_L = \sum_0^{\infty} a_n \sin(2n+1)\omega t + b_n \cos(2n+1)\omega t \quad (1)$$

where  $\omega$  is the angular frequency of the supply voltage. It should be noted that a nonlinear load current contains only odd harmonic components.

## 3. Proposed Control Scheme

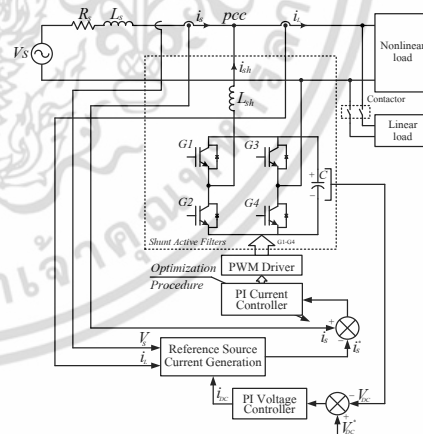

**Fig.2** The proposed control scheme

The propose control scheme is shown in Fig. 2. Reference source current generation block is used to calculate the reference source current ( $i_S^*$ ) from the measured load current ( $i_L$ ) with the use of synchronous rotating frame. Since the transformation to this frame of reference requires transformation angle ( $\theta$ ), supply voltage is measured and a phased-locked loop (PLL)

topology is used to provide this angle. There are two control loops, a dc-link voltage control and source current control. In the dc voltage control, ( $V_{DC}$ ) is kept constant at its reference a traditional PI controller. The output of PI voltage controller ( $i_{DC}$ ) is the d-axis current. This dc current controls the power flow in and out of the capacitor. In this work, the source current will be controlled therefore  $i_{DC}$  is sent to reference generation block in order to correctly generate reference source current. The source current control employs a simple PI controller which controller gains will be obtained by the optimization procedure based on GA to obtain its best performance.

### 3.1 Reference Source Current Generation using Single-Phase d-q Transformation

The block diagram used to generate reference source current is shown in Fig. 3. It is based on a synchronous d-q frame of reference. Unlike a three-phase system, in order to apply the d-q transformation to a single-phase system a modification is required. The  $i_{L\beta}$  is obtained from the measurement of  $i_L$  before shifted or delayed the signal by  $\pi/2$ . The original signal with a delayed signal can be considered as equivalent representation of single-phase system in  $\alpha$ - $\beta$  frame of reference as in (2). Then the load currents in  $\alpha$ - $\beta$  frame of reference ( $i_{L\alpha}$ ,  $i_{L\beta}$ ) are transformed to d-q frame of reference using  $\sin \omega t$  and  $\cos \omega t$  using (3) and (4).

$$\begin{bmatrix} i_{L\alpha} \\ i_{L\beta} \end{bmatrix} = \begin{bmatrix} i_L(\omega t) \\ i_L(\omega t - \pi/2) \end{bmatrix} \quad (2)$$

$$\begin{bmatrix} i_{Ld} \\ i_{Lq} \end{bmatrix} = \begin{bmatrix} \sin \omega t & -\cos \omega t \\ \cos \omega t & \sin \omega t \end{bmatrix} \cdot \begin{bmatrix} i_{L\alpha} \\ i_{L\beta} \end{bmatrix} \quad (3)$$

$$\begin{bmatrix} i_{Ld} \\ i_{Lq} \end{bmatrix} = \begin{bmatrix} i_{L\alpha} \cdot (\sin \omega t) - i_{L\beta} \cdot (\cos \omega t) \\ i_{L\alpha} \cdot (\cos \omega t) + i_{L\beta} \cdot (\sin \omega t) \end{bmatrix} \quad (4)$$

As a result, the load currents in d-q frame of reference ( $i_{Ld}$  and  $i_{Lq}$ ) are obtained. The d-axis current ( $i_{Ld}$ ) and q-axis current ( $i_{Lq}$ ) will represent the active and reactive power components of the load current respectively.

The d and q-axis currents can be decomposed into the dc and ac components as given in (5). They are fundamental and harmonic currents respectively.

$$\begin{bmatrix} i_{Ld} \\ i_{Lq} \end{bmatrix} = \begin{bmatrix} \bar{i}_{Ld} + \tilde{i}_{Ld} \\ \bar{i}_{Lq} + \tilde{i}_{Lq} \end{bmatrix} \quad (5)$$

Since the essence of indirect current control method is to derive the reference source current,  $\bar{i}_{Lq}$ ,  $\tilde{i}_{Ld}$  and  $\tilde{i}_{Lq}$  are set to zero.

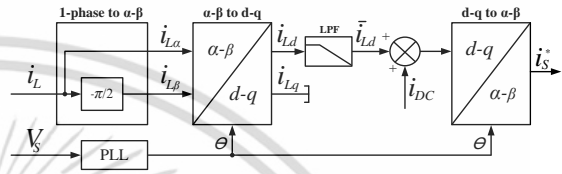

Fig.3 Reference source current generation using a single-phase synchronous d-q reference frame.

This corresponds to the fact that only fundamental active power is demanded by the loads. As mentioned, to extract fundamental component in load current ( $\bar{i}_{Ld}$ ) low pass filter is used as depicted in Fig.3. The filtered (dc) signal will be summed with  $i_{DC}$  which is the output current of voltage controller used to regulate the dc-link voltage. The summed current ( $\bar{i}_{Ld} + i_{DC}$ ) is then transformed back from synchronous reference frame to a stationary reference frame using the inverse Park transformation in (6). Finally, the reference source current ( $i_S^*$ ) is generated as given in (7).

$$\begin{bmatrix} i_{S\alpha}^* \\ i_{S\beta}^* \end{bmatrix} = \begin{bmatrix} \sin \omega t & \cos \omega t \\ -\cos \omega t & \sin \omega t \end{bmatrix} \cdot \begin{bmatrix} \bar{i}_{Ld} + i_{DC} \\ 0 \end{bmatrix} \quad (6)$$

$$i_S^*(\omega t) = (\bar{i}_{Ld} + i_{DC}) \sin \omega t \quad (7)$$

### 3.2 Genetic Algorithms for Controller Design

A GA is a stochastic global for controller design search method that is inspired by the theories of evolution and natural selection [11]. GA operates on a population of potential solutions, termed individuals, applying the principle of evolution, simulated by means of mathematical

operations that mimic the process of selection, crossover and mutation.

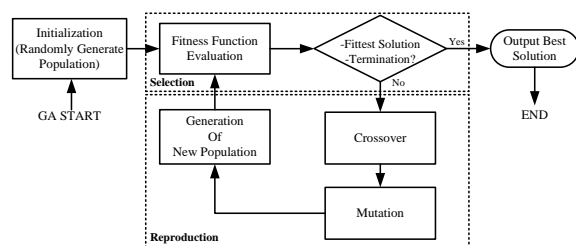

**Fig.4** The GA-based design routine.

Fig. 4 shows a basic GA routine. A GA-based routine starts with a population of individuals generated randomly. During each iteration, successive populations of strings were generated through three operators: reproduction, crossover and mutation. Reproduction is a process in which individuals in the current population are evaluated using a measure of their objective function values, called fitness function. The GA will seek the solution that maximizes or minimizes the fitness function. A fitness function measures the fitness of an individual to survive in a population of individuals. Individuals with a lower value of fitness function have a higher probability of contributing one or more offspring in the next generation. The selection of fitness function used to evaluate fitness of each individual is the crucial step and can be defined in many different ways based on different target specifications. Since the main aim of active filter control is to minimize both magnitude and phase error, [12] have presented optimization designs of controllers for SAF. They used the integral of absolute error (IAE) between the demanded and measured filter currents as fitness function. Unlike direct current control, the indirect current control is employed in this work. The fitness function is therefore defined as the measure of the integral of absolute error between the demanded and measured source currents as given in (8):

$$IAE = \int_{t_0}^T |i_s(t) - i_s^*(t)| dt \quad (8)$$

where  $t_0$  is the starting time and  $T$  is the total simulation time in each simulation. The

evaluation of the fitness function does not start until  $t_0$  to prevent the effect of all simulation initializations which can affect the optimization result.

The setting parameters for GA routine are listed in Table 1. The optimization is performed through 50 generations with each generation having 20 individuals. At the end of the optimization process, the GA returns optimum gain parameter. This gain, when used within the simulation, provides the least IAE possible within the predefined search area of the gain parameters.

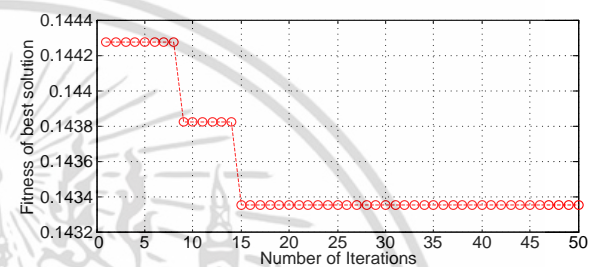

**Fig.5** Fitness of best solution against iterations.

In each simulation, the total simulation time is 0.6 seconds. It should be noted that the calculation of the fitness function does not start until  $t=0.15$ s. This prevents simulation initialization transients affecting the result. After the optimization is completed, the GA returns the optimized gains which are 4.8535 and 0.1569. The final PI controller has the equation in (9). The plot of the fitness of the best solution over the number of iterations is shown in Fig. 5.

$$C(s) = 4.8535 + 0.1569/s \quad (9)$$

## 4. Simulation Results

The proposed control strategy has been modeled using MATLAB/SIMULINK and SimPowerSystems. The simulations work with the component parameters and operation conditions given in Table 1. The performance of the proposed control strategy has been investigated as follows.

Fig. 6 and 7 show the current waveforms used to generate the source reference current ( $i_s^*$ ). After the reference current is achieved, the optimized PI controller has been evaluated in the presence of a nonlinear load

which in this work is an inductively smoothed uncontrolled rectifier. Load parameters are given in Table 1.

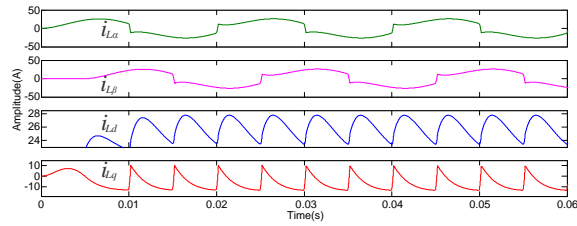

Fig.6  $i_{L\alpha}, i_{L\beta}, i_{Ld}$  and  $i_{Lq}$

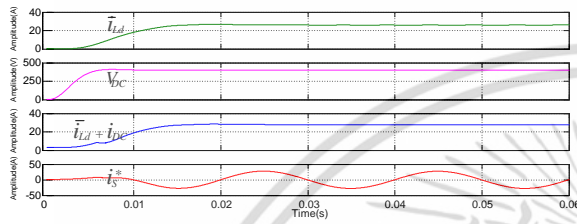
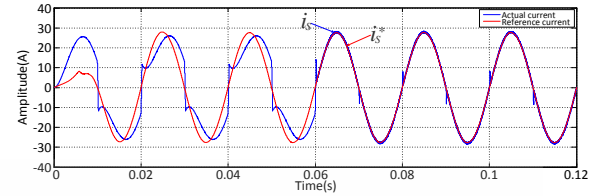

Fig.7  $\bar{i}_{Ld}, V_{DC}, \bar{i}_{Ld} + i_{DC}$  and  $i_S^*$

Fig. 8 illustrates the control performance. The compensation is set to start at  $t=0.06$  s. It can be seen that before starting the compensation, the source current and the nonlinear load current waveforms are the same. After starting the compensation, the actual current rapidly tracks the reference current and the source current waveform is obviously improved. It becomes sinusoidal as shown. A total harmonic distortion (THD) of the source current is reduced from 27.06% to 2.86% after the compensation. To evaluate the transient performance, a linear load (R-L load) is connected to a system via a contactor. The connection is take place at  $t=0.12$  s. Fig. 9 shows signal waveforms. The performance the current control is excellent which can be seen that  $i_S$  accurately follows  $i_S^*$  rapidly. It can be noticed from Fig.9 (a) that it takes around half a cycle of the source voltage to calculate the new reference source current. Fig.10 shows the comparison of  $i_S$  and  $i_S^*$  between using optimized GA controller and trial and error controller. It is clearly seen that the compensating performance has been improved with the proposed controller-total harmonic distortion (THD) of source current is reduced from 27.06% to 2.86% while in

case of using trial and error controller is reduced to 10.18%. Future works will be the optimized design of LPF used for generating source reference current and the hardware implementation of the proposed system.



(a).  $i_S, i_S^*$

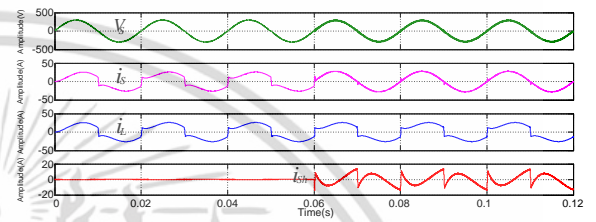

(b).  $V_S, i_S, i_L$  and  $i_{Sh}$

Fig.8 Performance of SAF: Before and after starting compensation at  $t=0.06$  s.

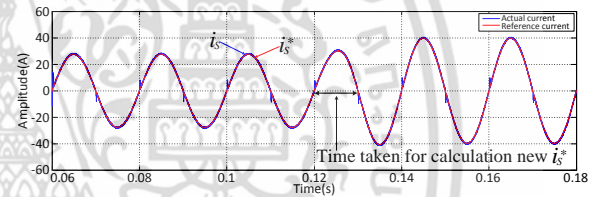

(a).  $i_S, i_S^*$

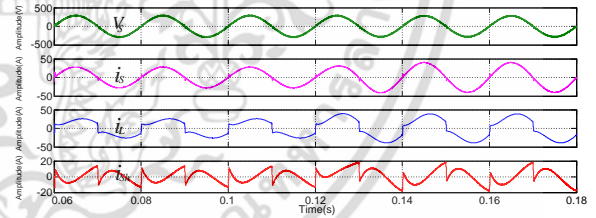

(b).  $V_S, i_S, i_L$  and  $i_{Sh}$

Fig.9 Performance of SAF: Linear loads is added at  $t = 0.12$  s.

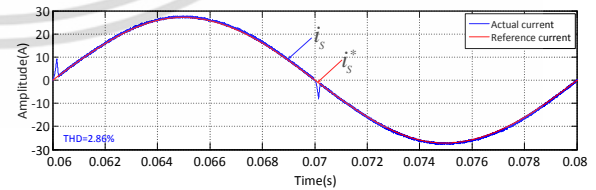

(a).Using optimized GA controller

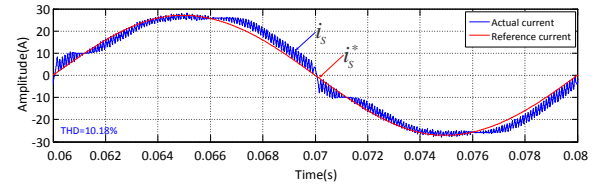

(b).Using trial and error controller

เอกสารนี้เป็นเอกสารที่สงวนไว้สำหรับการใช้งานเพื่อการศึกษาเท่านั้น ไม่อนุญาตให้นำไปใช้ประโยชน์ด้านการค้า  
ไม่ว่ากรณีใดๆ ทั้งสิ้น อีกทั้งห้ามมิให้ตัดแปลงเนื้อหา และต้องอ้างอิงถึงเจ้าของเอกสารทุกครั้งที่มีการนำไปใช้

**Fig. 10** Comparison of compensating performance between GA based controller and Trial and error controller

## 5. Conclusion

This paper presents the control design of a single-phase shunt active filter based on an indirect current control and the single-phase synchronous d-q reference frame to generate reference source current. By using an indirect current control technique source current control can be achieved by using PI controller which is preferable for most of commercial control system. Optimization of controller gains is obtained with GA. A detailed design procedure has been presented and applied to the current control system. The performance of the proposed control strategy has been investigated by simulations. The results exhibit excellent control of source current during both steady state and transient conditions. A total harmonic distortion (THD) of source current is reduced from 27.06% to 2.86% in case of nonlinear load while it is reduced from 17.83% to 2.06% in case of a combined nonlinear load and linear load. Thus, with the use of optimization procedure such as GA, it can therefore be considered as an effective tool for a control design for shunt active filter with an indirect current control.

**Table 1** Shunt active filter system and parameters for simulation test

AC supply voltage and frequency	Vrms = 220 V, 50 Hz
Nonlinear load(Bridge Rectifier) - inductor and resister	20 mH, 10 $\Omega$
Linear load	25 mH, 20 $\Omega$
AC side impedance	0.1 mH, 0.5 $\Omega$
Active Filter impedance	3.3 mH, 0.3 $\Omega$
DC voltage reference	400 V
DC-link capacitor	2200 $\mu$ F
Inverter Rating	5 kVA
Switching frequency	20 kHz
Sampling time	2 $\mu$ s
Switching device	IGBT
GA: $K_p$ gain range	[0-10]
GA: $K_i$ gain range	[0-10]
GA generation gap	0.9
GA crossover rate	0.7
GA mutation rate	0.05

## 6. References

- [1] H-L. Jou, J-C. Wu and H-Y. Chu, "New single-phase active power filter," IEE Proc. Electr. Pow. Appl., Vol.141.3, pp.129–134, 1994.
- [2] C. Y. Hsu and H. Y. Wu, "A new single-phase active power filter with reduced energy-storage capacity," IEE Proc. Electron. Pow. Appl., Vol.143, No.1, pp.25–30, Jan., 1996.
- [3] S. Bhattacharya and D.Divan, "Synchronous frame based controller implementation for a hybrid series active filter system," in Conf. Record 30th IEEE Ind. Appl. Soc. Annu. Meeting, Vol.3, pp.2531–2540, 1995.
- [4] H. Akagi, Y. Kanazawad, and A. Nabae, "Instantaneous Reactive Power Compensators Comprising Switching Devices without Energy Storage Components," IEEE Trans. Ind. Appl., Vol.20, No.3, pp.625-630, May/June., 1984.
- [5] Liu 1, Yang J. and Z. Wang, "A new approach for single-phase harmonic current detecting and its application in a hybrid active power filter," in Proc. Annu. Conf. IEEE Ind. Electron. Soc., Vol 2, pp.849-854, Dec., 1999.
- [6] J. Barros and E. Perez, "An adaptive method for determining the reference compensating current in single-phase shunt active power filters," IEEE Trans. Power Del., Vol.18, No.4, pp.1578–1580, Oct., 2003.
- [7] T. Komrska, J. Zák, and Z. Peroutka, "Control strategy of active power filter with adaptive FIR filter-based and DFT-based reference estimation," Power Electronics Electrical Drives Automation and Motion, pp.1524-1529, Jun., 2010.
- [8] Y. Khadkikar, M. Singh, A. Chandra, and B. Singh, "Implementation of single-phase synchronous dq reference frame controller for shunt active filter under distorted voltage condition," in Proc. IEEE PEDES Conf., pp.1-6, Dec., 2010.
- [9] Adel Mohamed, Sherif Zaid, and Osama Mahgoub. "Improved active power filter performance based on an indirect current control technique," Journal of power electronics(JPE), pp.931-937, Jun., 2011.
- [10] Q. N. Trinh and H. H. Lee, "An advanced current control strategy for three-phase shunt active power filters," IEEE Trans. Ind. Electron., Vol.60, No.12, pp.5400–5410, Dec., 2013.
- [11] Z. Michalewicz, Genetic algorithms + Data structures = Evolution programs, Springer-Verlag, 1996.
- [12] W. Lenwari, M. Sumner, and P. Zanchetta, "The use of genetic algorithms for the design of resonant compensators for active filters," IEEE Trans. Ind. Electron., Vol.56, No.8, pp.2852-2861, Aug., 2009.

เอกสารนี้เป็นเอกสารที่สงวนไว้สำหรับการใช้งานเพื่อการศึกษาเท่านั้น ไม่อนุญาตให้นำไปใช้ประโยชน์ด้านการค้า

ไม่ว่ากรณีใดๆ ทั้งสิ้น อีกทั้งห้ามมิให้ดัดแปลงเนื้อหา และต้องอ้างอิงถึงเจ้าของเอกสารทุกครั้งที่มีการนำไปใช้