

**THE ECG SYNCHRONIZED AUTOMATIC  
CARDIOPULMONARY RESUSCITATION SYSTEM**



**RAWIN KEAKULTANES**

**A THESIS SUBMITTED IN PARTIAL FULFILLMENT OF THE  
REQUIREMENT FOR THE DEGREE OF MASTER OF  
ENGINEERING IN BIOMEDICAL ENGINEERING SCHOOL OF  
ENGINEERING KING MONGKUT'S INSTITUTE OF  
TECHNOLOGY LADKRABANG**

**2023**

**KMITL-2023-EN-M-317-107**

This material is reserved for educational use only, not allowed for commercial use.

Forbidden to modify the content, and cite the document when use.



**COPYRIGHT 2023**

**SCHOOL OF ENGINEERING**

**KING MONGKUT'S INSTITUTE OF TECHNOLOGY LADKRABANG**

This material is reserved for educational use only, not allowed for commercial use.

Forbidden to modify the content, and cite the document when use.

Thesis	THE ECG SYNCHRONIZED AUTOMATIC CARDIOPULMONARY RESUSCITATION SYSTEM
Student	Mr. Rawin Keakultanes
Student ID.	65016073
Degree	Master of Engineering
Program	Biomedical Engineering
Year	2023
Thesis Advisor	Assoc.Prof.Dr.Chuchart Pintavirooj

## ABSTRACT

Cardiac arrest occurs when the heart unexpectedly malfunctions and stops breathing and pumping blood. Cardiopulmonary resuscitation, an emergency resuscitation procedure, must be performed as soon as possible when the patients suffer cardiac arrest to prevent brain damage or stop breathing. If not, it may lead to a person dead even in a short time (from 8-10 minutes) of cardiac arrest. According to the American Heart Association, proper CPR must be performed at a depth of 5 cm in the sternum and a rate of chest compressions of 100 to 120 breaths per minute. Therefore, medical personnel or the person who performs CPR must be well-trained to conduct proper CPR. For this reason, CPR machines are demanded to assist and support medical personnel in saving human lives. The automatic resuscitation system is a technological solution aimed at improving the efficiency and effectiveness of cardiopulmonary resuscitation (CPR) procedures. The system integrates features such as an App Inventor interface for easy control and monitoring, a linear actuator for chest compressions, and an optical-based pressure measurement system for assessing pressure distribution. Through extensive testing and evaluation, the system demonstrates its ability to deliver precise chest compressions and provide real-time feedback on the effectiveness of resuscitation efforts. By leveraging technology and innovation, this automatic resuscitation system offers a promising approach to enhancing CPR outcomes and ultimately saving lives.

This material is reserved for educational use only, not allowed for commercial use.

Forbidden to modify the content, and cite the document when use.

## ACKNOWLEDGEMENTS

This project would not be complete without the assistance of many people. I'd like to express my gratitude to the biomedical engineering department, professors, family, and everyone else for providing me with the opportunity to study in this department and have been there for me throughout the last few years.

My project advisor, Assoc.Prof. Dr. Chuchart Pintavirooj, assisted me in completing this project. I am able to complete the objective that I have intended thanks to the comments and corrections received throughout this project.

This project was passed down from Miss Thananchanok Anu-ekjit, and I'd like to express my gratitude to Miss Thananchanok for her assistance with this project. In addition, I'd like to thank the Faculty of Engineering, particularly the Biomedical Engineering Department, for providing the research space and equipment necessary to finish this project.

Finally, I'd like to express my gratitude to all of the other persons who assisted and supported me throughout the making of this project.

Rawin Keakultanes

## TABLE OF CONTENTS

	Page
ABSTRACT.....	(i)
ACKNOWLEDGEMENTS .....	(ii)
LIST OF TABLES .....	(vii)
LIST OF FIGURES .....	(viii)
LIST OF SYMBOLS/ABBREVIATIONS .....	(xi)
CHAPTER 1 INTRODUCTION .....	1
1.1 What is cardiopulmonary resuscitation?.....	1
1.2 The need for automation of CPR .....	3
1.3 Objectives of the study.....	4
1.4 Scope of the study.....	5
CHAPTER 2 OVERVIEW OF AUTOMATED CPR SYSTEM .....	6
2.1 Cardiopulmonary resuscitation (CPR) .....	6
2.2 History of CPR .....	6
2.3 When to Use Automated CPR.....	8
2.4 Difference between Cardiac Arrest and Cardiac Attack .....	8
2.5 Method of cardiopulmonary resuscitation.....	9
2.6 CPR Techniques.....	11
2.7 Difference method of cardiopulmonary resuscitation between Infant, Children, and Adults .....	12
2.7.1 Method of performing cardiopulmonary resuscitation for Infant .....	12
2.7.2 Method of performing cardiopulmonary resuscitation for child .....	13

This material is for personal use only. It is forbidden to modify the content, and cite the document when use.

2.7.3 Method of performing cardiopulmonary resuscitation for adults .....	15
2.8 EXISTING MECHANICAL CPR DEVICES .....	16
2.8.1 Lucas chest compression system .....	18
2.8.2 The ZOLL AutoPulse Resuscitation System.....	19
2.8.3 ResQPump Automatic CPR Device .....	21
2.8.4 EASY PULSE CPR Device .....	23
2.9 The effectiveness of the automatic CPR devices .....	25
2.9.1 Is CPR that is performed automatically effective?.....	26
2.9.2 The time considerations.....	27
2.9.3 The safety considerations .....	28
2.9.4 Situational factors.....	29
2.9.5 Economic considerations.....	30
2.10 The automatic cardiopulmonary resuscitation device materials .....	32
2.10.1 Linear actuator.....	33
2.10.2 Motor driver .....	35
2.10.3 Arduino Uno.....	40
2.10.4 Ultrasonic sensor.....	43
2.10.5 Bluetooth Module.....	45
2.10.6 Pushbutton.....	46
2.10.7 Power source .....	48
2.10.7.1 AC adapter.....	49
2.10.8 Force sensor.....	51
2.10.9 ECG Module.....	53
2.10.9.1 Abnormal electrocardiogram.....	55
2.11 Chapter 2 Summary.....	56
CHAPTER 3 SYSTEM INSTALLATION AND DESIGN .....	57
3.1 Introduction .....	57
3.2 Material and method.....	58
3.3 Design of automatic cardiopulmonary resuscitation device .....	60

3.4 App Inventor .....	68
3.5 Circuit diagrams.....	72
3.6 Hardware part.....	76
3.7 Optical-Based Pressure Measurement System.....	82
3.8 Proposed Solution .....	84
3.9 Chapter 3 Summary.....	85
CHAPTER 4 EXPERIMENTAL RESULT .....	87
4.1 Introduction .....	87
4.2 Evaluation .....	87
4.2.1 Performance and Effectiveness.....	87
4.2.2 Limitations and Areas for Improvement.....	88
4.3 Compression result.....	93
4.4 The compression rate .....	96
4.5 FSR result.....	97
4.6 ECG result.....	98
4.6.1 ECG result 30 bpm.....	99
4.6.2 ECG result 60 bpm.....	100
4.6.3 ECG result 120 bpm.....	101
4.6.4 ECG result with noise .....	103
4.7 Ultrasonic and ECG .....	105
4.7.1 Ultrasonic and ECG 30 bpm.....	105
4.7.2 Ultrasonic and ECG 60 bpm.....	106
4.7.3 Ultrasonic and ECG 120 bpm.....	107
4.7.4 Ultrasonic and ECG 30 bpm.....	108
4.8 Pressure map result .....	109
4.8.1 Pressure map measurement by 100 mm diameter rubber.....	112
4.8.2 Pressure map measurement by 30 mm diameter rubber .....	115

4.8.3 Pressure map measurement by linear actuator .....	116
4.8.4 Pressure map measurement by hand .....	119
4.8.5 Pressure map measurement summary .....	120
4.9 Testing Summary .....	121
4.10 Testing and Evaluation Summary .....	123
<b>CHAPTER 5 CONCLUSION .....</b>	<b>125</b>
5.1 Introduction .....	125
5.2 Summary .....	125
5.3 Conclusions .....	127
5.4 Future work .....	129
<b>REFERENCES.....</b>	<b>132</b>
<b>APPENDICES</b>	
APPENDIX A .....	149
APPENDIX B .....	153
APPENDIX C .....	155
APPENDIX D .....	157
APPENDIX E .....	159
<b>BIOGRAPHY .....</b>	<b>161</b>

## LIST OF TABLES

Tables	Page
3.6.5 FSR sensors calibration.....	80
4.3 Ultrasonic data on serial monitor.....	94
4.8 A set of known weights and the associated computed forces and pressures and Plot of average intensity and the pressure [158].....	111



## LIST OF FIGURES

Figures	Page
2.8.1 Lucas’s chest compression machine [44] .....	19
2.8.2 ZOLL AutoPulse Resuscitation System [50].....	21
2.8.3 ResQPump Automatic CPR Device [55] .....	22
2.8.4 EASY PULSE CPR Device [61] .....	24
2.10.1 LX800 linear actuator motor [91] .....	34
2.10.2 Motor driver L298N [96].....	37
2.10.2.1 Motor driver shield MD10 R2 [101].....	39
2.10.3 Arduino Uno [112].....	42
2.10.4 Ultrasonic sensors [121] .....	44
2.10.5 Bluetooth Module HC-05 [127].....	46
2.10.6 Red and Green momentary push button switch [131] .....	47
2.10.7 Power supply [137].....	49
2.10.7.1 AC adapter [143].....	50
2.10.8 Force sensitive resistor [148].....	52
2.10.9 ECG module [154].....	54
3.3.1 Design of the base of automatic CPR device.....	60
3.3.2 Design of the motor holder of automatic CPR device .....	61
3.3.3 Design of the rubber of automatic CPR device .....	62
3.3.4 Linear actuator connector .....	63
3.3.5 Assembly design of the automatic CPR device .....	64
3.3.6 Assembly design of the emergency ventilator .....	66
3.4 App Inventor interface design.....	68
3.4.1 App Inventor block diagram .....	70
3.5 Circuit diagram for compression linear actuator .....	72
3.5.1 Circuit diagram for the second linear actuator.....	73
3.5.2 Circuit diagram for force sensors .....	74

## LIST OF FIGURES (Continue)

3.5.3 Circuit diagram for ECG module [157].....	75
3.6.1 Second linear actuator installation.....	76
3.6.2 The Automatic CPR machine.....	77
3.6.3 ECG module and FSR sensors.....	78
3.6.4 FSR sensors position.....	79
3.6.6 Total assembly of the automatic CPR system.....	81
3.7 Design of optical-based pressure measurement device [158].....	83
4.2 Hand position.....	89
4.2.1 Ultrasonic display on mobile phone.....	91
4.3 Graph showing compression data.....	93
4.5 FSR results on serial monitor.....	97
4.6.1 ECG results on serial plotter (30 bpm).....	99
4.6.1.2 ECG time delay on serial plotter (30 bpm).....	99
4.6.2 ECG result on serial plotter (60 bpm).....	100
4.6.2.2 ECG time delay on serial plotter (60 bpm).....	101
4.6.3 ECG results on serial plotter (120 bpm).....	101
4.6.3.2 ECG time delay on serial plotter (120 bpm).....	102
4.6.4 ECG results on serial plotter with noise.....	103
4.7.1 ECG results and ultrasonic distance at 30 bpm.....	105
4.7.2 ECG results and ultrasonic distance at 60 bpm.....	106
4.7.3 ECG results and ultrasonic distance at 120 bpm.....	107
4.7.4 ECG atrial fibrillation results on serial plotter with ultrasonic.....	108
4.8 Optical-Based Pressure Measurement device.....	109
4.8.1 100mm diameter rubber.....	113
4.8.1.1 Pressure results from 100mm diameter rubber.....	113
4.8.1.2 Pressure results from 100mm diameter rubber that tilted during compression.....	114
4.8.2 30mm diameter rubber on linear actuator.....	115
4.8.2.1 Pressure results from 30mm diameter rubber.....	115
4.8.3 Pressure results from linear actuator.....	117

This document is intended for educational use only, not allowed for commercial use.

## LIST OF FIGURES (Continue)

4.8.3.1 Head of linear actuator.....	118
4.8.4 Pressure results of hand .....	119



## LIST OF SYMBOLS/ABBREVIATIONS

<b>Symbols/Abbreviations</b>	<b>Terms</b>
CPR	Cardiopulmonary resuscitation
CPM	Compression per minute
AHA	American Heart Association
CPP	Coronary perfusion pressure
RAP	Right atrial pressure
ETCO <sub>2</sub>	End-tidal carbon dioxide
LDB	Load-distributing band
ROSC	Return of Spontaneous Circulation
BVM	Bag valve mask
CIRC	Circulation improving resuscitation care
CT	Computed tomography
PWM	Pulse Width Modulation
USB	Universal Serial Bus
LED	Light Emitting Diode
V	Voltage
GND	Ground
Hz	Hertz
AF	Atrial fibrillation
mm	Millimeter
cm	Centimeter
in	Inch
ECG	Electrocardiogram
EMS	Emergency medical services
AED	Automated external defibrillator
BPM	Beats per minute

# CHAPTER 1

## INTRODUCTION

This chapter discusses the overall topics of this study and situates the rationale for the work within a broader historical and philosophical framework. Following that, the reason for the project's inquiry and the objectives that have been established are described, followed by a description of the project as a whole. Finally, a summary of the dissertation is provided on a chapter-by-chapter basis at the conclusion.

The purpose of this chapter is to introduce the automatic resuscitation system project, highlighting the need for automation in cardiopulmonary resuscitation (CPR). It outlines the objectives of the project, focusing on improving the effectiveness and efficiency of resuscitation efforts. By establishing the importance of automation in CPR and setting clear project goals, Chapter 1 sets the stage for the subsequent chapters, which delve into the system's design, implementation, experimental results, and future possibilities.

### 1.1 What is cardiopulmonary resuscitation?

Cardiopulmonary resuscitation (CPR) is a life-saving technique that is used to restore the function of the heart and lungs in individuals who have suffered cardiac arrest or respiratory failure. CPR is a vital tool in emergency medical care and is a fundamental skill that every person should learn [1]. CPR is designed to provide a constant flow of oxygenated blood to the vital organs of the body, especially the brain until medical professionals can take over. It involves a combination of chest compressions and rescue breathing, which work together to restore circulation and breathing in the individual. Chest compressions are performed by pressing down on the chest of the individual to stimulate the heart to pump blood. Rescue breathing involves providing artificial respiration to the individual by blowing air into their lungs, mimicking the process of normal breathing [2]. The primary goal of CPR is to maintain the flow of oxygenated blood to the brain and other vital organs, preventing brain damage and death. The brain can survive for only a few minutes without oxygen, and the chances of survival decrease rapidly with each passing minute. Therefore, it is

This material is reserved for educational use only, not allowed for commercial use.

Forbidden to modify the content, and cite the document when use.

essential to start CPR as soon as possible and to continue until medical help arrives. CPR can be performed on individuals of all ages, including infants, children, and adults. The technique may vary slightly depending on the age and size of the individual, but the basic principles remain the same. CPR is a critical skill that can be the difference between life and death in emergency situations. The American Heart Association recommends that everyone learn CPR, and various courses are available to teach the technique to individuals of all backgrounds and experience levels. Many workplaces, schools, and community organizations also offer CPR training to their members to prepare them to respond in an emergency [3].

There are different types of CPR that can be used depending on the situation and the age of the patient. In this essay, we will discuss the three main types of CPR, including hands-only CPR, conventional CPR, and pediatric CPR, along with references to support the information.

#### 1. Hands-only CPR

Hands-only CPR, also known as compression-only CPR, is a simplified version of CPR that involves performing chest compressions without rescue breaths. This technique is recommended for adults who have collapsed due to sudden cardiac arrest and do not show signs of breathing. It has been shown to be just as effective as conventional CPR in the early stages of cardiac arrest.

The American Heart Association (AHA) recommends that bystanders who witness a sudden collapse should call 911 and immediately start hands-only CPR until emergency medical services arrive. Hands-only CPR involves pressing down on the center of the chest at a rate of 100-120 compressions per minute until help arrives [1].

#### 2. Conventional CPR

Conventional CPR involves a combination of chest compressions and rescue breaths. This technique is recommended for individuals of all ages who have suffered cardiac arrest or respiratory failure. It involves pressing down on the chest to stimulate the heart to pump blood while also providing artificial respiration to the individual by blowing air into their lungs [4].

The AHA recommends that bystanders should call 911 and start conventional CPR immediately on individuals who have collapsed and are not breathing normally. The

technique involves performing 30 chest compressions followed by two rescue breaths, repeating the cycle until help arrives.

### 3. Pediatric CPR

Pediatric CPR is a specialized form of CPR designed for infants and children. The technique involves modifications to the conventional CPR technique to account for the smaller size and different anatomy of children [5].

The AHA recommends that bystanders who witness a child collapse should call 911 and start pediatric CPR immediately. The technique involves performing 30 chest compressions followed by two rescue breaths for infants and young children, and 15 chest compressions followed by two rescue breaths for older children.

There are different types of CPR that can be used depending on the situation and the age of the patient. Hands-only CPR is a simplified version of CPR that involves performing chest compressions without rescue breaths and is recommended for adults who have collapsed due to sudden cardiac arrest. Conventional CPR involves a combination of chest compressions and rescue breaths and is recommended for individuals of all ages. Pediatric CPR is a specialized form of CPR designed for infants and children. It is important to be familiar with the different types of CPR and to know when to use them to increase the chances of a positive outcome in emergency situations.

#### 1.2 The need for automation of CPR

CPR can be a crucial intervention in emergency situations, but it is also physically demanding and can be difficult to perform correctly, especially for non-medical personnel. This is where the need for automation of CPR comes in.

Automated CPR devices are designed to provide consistent, high-quality chest compressions without fatigue or interruption. They can be used by emergency medical technicians (EMTs) in ambulances, in hospital settings, and even by laypeople in public spaces like airports or shopping malls. The devices consist of a piston or plunger that is attached to a backboard or vest worn by the patient. The device delivers compressions at a set rate and depth, which can be adjusted to meet the patient's specific needs.

There are several reasons why the automation of CPR is necessary. First, manual chest compressions are physically demanding and can quickly lead to fatigue, especially for non-medical personnel who may not be trained or experienced in

This material is reserved for educational use only, not allowed for commercial use.

Forbidden to modify the content, and cite the document when use.

performing CPR. This can result in inconsistent compression depth and rate, which can lead to decreased blood flow and reduced chances of survival for the patient.

Second, automated CPR devices can provide consistent, uninterrupted compressions for extended periods, which can be critical in cases where prolonged resuscitation is necessary. Traditional manual CPR is difficult to sustain for more than a few minutes, and interruptions in chest compressions can decrease the patient's chances of survival.

Third, automated CPR devices can improve the safety of both the patient and the rescuer. Traditional CPR requires physical contact between the rescuer and the patient, which can expose the rescuer to bodily fluids and infectious diseases. Automated CPR devices eliminate this risk and can also provide more efficient compressions, reducing the risk of injury to the patient.

Finally, automated CPR devices can provide real-time feedback on the quality of chest compressions, allowing rescuers to make adjustments and improve the patient's chances of survival. Feedback can include information on compression rate, depth, and recoil, which can help rescuers ensure that they are providing effective chest compressions.

The automation of CPR is a necessary and important development in emergency medical care. Automated CPR devices can provide consistent, high-quality chest compressions without fatigue or interruption, improving the chances of survival for patients in cardiac arrest. They can also improve the safety of both the patient and the rescuer, and provide real-time feedback on the quality of chest compressions. As technology continues to advance, we can expect to see further improvements in automated CPR devices, making them even more effective and widely available.

### **1.3 Objectives of the study**

- Develop an automatic resuscitation system that is affordable and accessible for medical professionals in low-resource settings.
- Design a portable and lightweight device that can be easily transported and used in various emergency settings.
- Ensure the device meets necessary safety and regulatory standards for medical devices.

This material is reserved for educational use only, not allowed for commercial use.

Forbidden to modify the content, and cite the document when use.

- Incorporate feedback mechanisms to optimize chest compression rate, depth, and recoil.
- Conduct usability testing with medical professionals and non-medical personnel to ensure ease of use and effectiveness.
- Explore partnerships with international organizations to distribute the device to areas with limited access to emergency medical care.
- Provide training and education materials for users to maximize the impact of the device.
- Continuously evaluate and improve the device based on user feedback and technological advancements.

#### **1.4 Scope of the study**

The following is the structure of the remainder of this report:

Chapter 2 focuses on reviewing the history of CPR, the concept of automated CPR, existing automated CPR devices, and the materials used in the construction of the automatic CPR machine.

Chapter 3 delves into the installation process, design considerations, circuit diagram, and mobile app interface of the automatic CPR machine.

Chapter 4, the experimental results are presented, showcasing the functioning hardware machine, app interface, and providing analysis on compression depth and compression rate of the automatic CPR machine.

Chapter 5 concludes the report by evaluating the work accomplished thus far and offering insights into future directions for further improvements and advancements in the field of automatic CPR technology.

## **CHAPTER 2**

### **OVERVIEW OF AUTOMATED CPR SYSTEM**

This chapter provides a comprehensive overview of the automated cardiopulmonary resuscitation (CPR) system. It begins by exploring the history of CPR (section 2.2), tracing its evolution and significance in medical emergencies. The chapter then examines the concept of automated CPR, highlighting its advantages and the role it plays in enhancing the efficiency and effectiveness of resuscitation efforts (section 2.9). Furthermore, it presents an analysis of existing automated CPR devices (section 2.8), discussing their features, functionalities, and limitations. The chapter also delves into the materials utilized in the construction of the automatic CPR system (section 2.10), emphasizing the importance of quality and durability in ensuring optimal performance.

By delving into these aspects, Chapter 2 establishes a solid foundation for understanding the context, relevance, and advancements in automated CPR technology.

#### **2.1 Cardiopulmonary resuscitation (CPR)**

Cardiopulmonary resuscitation, commonly known as CPR, is a medical technique used to restore blood circulation and breathing in individuals who have experienced cardiac arrest or respiratory failure. It is a life-saving intervention that has been in use for over half a century and has helped to save countless lives [6]. However, performing manual CPR can be challenging, especially for untrained individuals, and can lead to fatigue, injuries, and even the inability to maintain a consistent rhythm. For this reason, automated CPR devices have been developed to assist in performing this vital procedure.

#### **2.2 History of CPR**

The history of CPR dates back to the early 1960s when the American Heart Association (AHA) first introduced the technique. At that time, CPR was only performed by medical professionals, including doctors and nurses, and was not widely known among the general public. However, over the years, the AHA has worked to

promote CPR education and training, and as a result, the technique has become more widely recognized and accepted [7].

One of the key developments in the history of CPR was the discovery of the importance of chest compressions. In the early days of CPR, the focus was on mouth-to-mouth resuscitation, but researchers soon discovered that chest compressions were equally important in restoring blood circulation. This discovery led to the development of the modern-day CPR technique, which involves a combination of chest compressions and rescue breaths [8].

Another important development in the history of CPR was the introduction of automated external defibrillators (AEDs). AEDs are portable devices that can be used to analyze the heart rhythm of a patient and deliver an electric shock if necessary to restore a normal heartbeat. AEDs have become increasingly common in public places, such as airports, sports stadiums, and shopping malls, and have been instrumental in saving countless lives [9].

#### Automated CPR Devices

Despite the success of CPR, performing the procedure can be challenging, especially for untrained individuals. Chest compressions must be delivered at a specific rate and depth, and maintaining a consistent rhythm can be difficult. For this reason, automated CPR devices have been developed to assist in performing this vital procedure.

Automated CPR devices come in various forms, including mechanical chest compression devices, load-distributing band devices, and piston-driven devices. Mechanical chest compression devices are the most common and are designed to deliver consistent chest compressions at a rate of 100-120 compressions per minute [10]. Load-distributing band devices use a constricting band to compress the chest, while piston-driven devices use a piston to compress the chest.

One of the advantages of automated CPR devices is that they eliminate the need for manual chest compressions, which can be physically demanding and tiring. This can be especially beneficial in situations where multiple rescuers are needed, as the device can provide continuous chest compressions while other interventions, such as defibrillation or medication administration, are being performed [11].

### **2.3 When to Use Automated CPR**

Automated CPR devices are typically used in situations where manual CPR is not feasible or when additional support is needed. For example, in a hospital setting, automated CPR devices may be used during surgeries or other procedures where it is necessary to maintain continuous chest compressions while other interventions are being performed.

Automated CPR devices may also be used in pre-hospital settings, such as during ambulance transport, where the physical demands of manual CPR can be challenging for paramedics and emergency medical technicians [12]. Additionally, automated CPR devices may be used in situations where multiple rescuers are needed, such as in a mass casualty incident or during a disaster response [13].

It is important to note that automated CPR devices should not be used as a substitute for manual CPR in all situations.

### **2.4 Difference between Cardiac Arrest and Cardiac Attack**

The terms "cardiac arrest" and "cardiac attack" are often used interchangeably to describe a sudden, life-threatening emergency involving the heart. However, these terms have distinct meanings and implications for treatment. Understanding the difference between cardiac arrest and cardiac attack is critical for prompt and appropriate intervention, which can mean the difference between life and death.

Cardiac arrest refers to the sudden cessation of the heart's ability to pump blood effectively. This results in a loss of blood flow to vital organs, including the brain, and can lead to irreversible damage or death within minutes if left untreated. Cardiac arrest can be caused by a variety of underlying conditions, such as coronary artery disease, arrhythmias, heart valve problems, or trauma. The most common cause of cardiac arrest in adults is a heart attack, in which a blockage in the coronary arteries deprives the heart muscle of oxygen and nutrients. However, cardiac arrest can also occur in the absence of a heart attack, due to other causes such as electrical abnormalities or sudden trauma [14].

On the other hand, a "cardiac attack" is not a medical term and is often used incorrectly to describe a heart attack or cardiac arrest. It is possible that the term is a misnomer for a "cardiac event," which is a broad term that can refer to any medical

This material is reserved for educational use only, not allowed for commercial use.

Forbidden to modify the content, and cite the document when use.

emergency involving the heart, including heart attack, cardiac arrest, or angina (chest pain due to reduced blood flow to the heart).

The key difference between cardiac arrest and a heart attack is the underlying mechanism of injury. As mentioned earlier, cardiac arrest occurs when the heart suddenly stops pumping blood effectively, whereas a heart attack occurs when blood flow to the heart muscle is blocked, usually due to a buildup of plaque in the coronary arteries. The symptoms of a heart attack can vary but may include chest pain or discomfort, shortness of breath, nausea, lightheadedness, or pain or discomfort in other areas of the upper body. If left untreated, a heart attack can progress to cardiac arrest.

The treatment for cardiac arrest and a heart attack differs significantly. In the case of cardiac arrest, immediate intervention is critical to restore blood flow and prevent irreversible damage or death. This typically involves cardiopulmonary resuscitation (CPR) and the use of automated external defibrillators (AEDs) to deliver an electric shock to the heart and restore normal rhythm. In contrast, the treatment for a heart attack typically involves medications, such as aspirin or nitroglycerin, to reduce blood clotting and improve blood flow, and interventions such as percutaneous coronary intervention (PCI) or coronary artery bypass surgery to restore blood flow to the heart [15].

Understanding the difference between cardiac arrest and a heart attack is essential for recognizing the signs and symptoms of these conditions and providing appropriate intervention. While cardiac arrest requires immediate CPR and defibrillation, a heart attack requires rapid medical treatment to restore blood flow to the heart muscle. Misusing the terms "cardiac arrest" and "cardiac attack" can lead to confusion and delay in proper intervention, which can have dire consequences. Therefore, it is important to use the correct medical terminology to describe these conditions and to seek medical attention promptly in case of any suspicion.

## **2.5 Method of cardiopulmonary resuscitation**

There are several methods of CPR that can be used in different situations, depending on the age of the victim, the cause of the cardiac arrest, and the skill level of the rescuer.

The basic method of CPR involves chest compressions and rescue breaths. According to the American Heart Association (AHA), the rescuer should first check the

This material is reserved for educational use only, not allowed for commercial use.

Forbidden to modify the content, and cite the document when use.

victim for responsiveness and breathing. If the victim is unresponsive and not breathing normally, the rescuer should call for emergency medical services (EMS) and begin chest compressions immediately [16]. The rescuer should kneel beside the victim, place the heel of one hand on the center of the victim's chest, and place the other hand on top of the first hand. The rescuer should then push down on the chest with both hands at a rate of 100 to 120 compressions per minute, allowing the chest to recoil between compressions. After 30 compressions, the rescuer should give two breaths to the victim, tilting the head back and lifting the chin to open the airway. The breaths should be given over 1 second each, with enough volume to make the chest rise. The rescuer should continue with cycles of 30 compressions and 2 breaths until EMS arrives or the victim shows signs of life [16].

Another method of CPR is hands-only CPR, which involves chest compressions only, without rescue breaths. According to the AHA, hands-only CPR can be as effective as traditional CPR in adult victims of cardiac arrest caused by a heart attack or other medical issues [17]. Hands-only CPR is performed in the same way as traditional CPR, but without rescue breaths. The rescuer should place the heel of one hand on the center of the victim's chest and push down hard and fast, at a rate of 100 to 120 compressions per minute, until EMS arrives, or the victim shows signs of life [17].

In some cases, CPR may be performed using a device called an automated external defibrillator (AED), which is a portable device that delivers an electric shock to the heart to restore its normal rhythm. According to the AHA, an AED can be used on any victim of cardiac arrest, regardless of the cause [18]. To use an AED, the rescuer should turn on the device, attach the pads to the victim's chest, and follow the voice prompts provided by the device. The AED will analyze the victim's heart rhythm and determine whether a shock is needed. If a shock is needed, the AED will charge up and instruct the rescuer to clear the victim before delivering the shock [18]. After the shock is delivered, the rescuer should resume CPR until EMS arrives or the victim shows signs of life.

CPR is a life-saving technique that can be performed in various ways depending on the situation. The basic method of chest compressions and rescue breaths is the most common, but hands-only CPR and the use of an AED are also effective methods that can be used in certain situations. Regardless of the method used, the key to successful

This material is reserved for educational use only, not allowed for commercial use.

Forbidden to modify the content, and cite the document when use.

CPR is to start immediately and continue until EMS arrives or the victim shows signs of life.

## 2.6 CPR Techniques

There are several techniques for performing CPR, each with its own advantages and disadvantages.

The basic technique for performing CPR involves chest compressions and rescue breaths. The rescuer should position themselves at the victim's side and place the heel of one hand on the center of the victim's chest, then place the other hand on top of the first hand. The rescuer should then push down on the chest with both hands, using their body weight to compress the chest by about two inches. After 30 compressions, the rescuer should perform two rescue breaths, tilting the victim's head back and lifting their chin before blowing two breaths into their mouth. This cycle should be repeated until emergency medical services arrive [19].

Another technique for performing CPR is the hands-only technique, which involves chest compressions without rescue breaths. This technique is recommended for individuals who are not trained in CPR or who are uncomfortable performing rescue breaths. The hands-only technique involves positioning oneself at the victim's side and placing the heel of one hand on the center of the victim's chest, then placing the other hand on top of the first hand. The rescuer should then push down on the chest with both hands, using their body weight to compress the chest by about two inches. This cycle should be repeated until emergency medical services arrive [20].

The compression-only technique is another method of performing CPR. This technique involves continuous chest compressions without rescue breaths. The rescuer should position themselves at the victim's side and place the heel of one hand on the center of the victim's chest, then place the other hand on top of the first hand. The rescuer should then push down on the chest with both hands, using their body weight to compress the chest by about two inches. This cycle should be repeated until emergency medical services arrive [21].

In addition to these techniques, there are several variations of CPR that can be used depending on the situation. For example, infant CPR involves using two fingers to perform chest compressions and rescue breaths on a child under the age of one. The

This material is reserved for educational use only, not allowed for commercial use.

Forbidden to modify the content, and cite the document when use.

American Heart Association also recommends using an automated external defibrillator (AED) in conjunction with CPR to improve outcomes for cardiac arrest patients. An AED is a portable device that delivers an electric shock to the heart to restore its normal rhythm. AEDs are designed to be used by individuals without medical training and can significantly improve survival rates for cardiac arrest patients [22].

CPR is a life-saving emergency medical procedure that can significantly improve outcomes for cardiac arrest patients. There are several techniques for performing CPR, each with its own advantages and disadvantages. These techniques include the basic technique, the hands-only technique, and the compression-only technique, as well as variations of CPR for infants and the use of an AED. It is important for individuals to be trained in CPR and to know which technique to use in a given situation in order to improve the chances of survival for cardiac arrest patients.

## **2.7 Difference method of cardiopulmonary resuscitation between Infant, Children, and Adults**

### **2.7.1 Method of performing cardiopulmonary resuscitation for Infant**

Performing cardiopulmonary resuscitation (CPR) on an infant is a critical life-saving technique. According to the American Heart Association (AHA), an infant is defined as a child who is 28 days old to 1 year of age [23]. In this age group, sudden cardiac arrest is rare, but it can happen due to several factors, such as respiratory distress, trauma, choking, and congenital heart disease.

The first step in performing CPR on an infant is to ensure that the environment is safe. Check for any potential hazards that may cause harm to the infant or the rescuer. The rescuer should then check the infant's responsiveness by gently tapping or shaking the infant's shoulder and shouting their name [24]. If there is no response, the rescuer should shout for help and immediately call for emergency medical services (EMS). If there is another person available, they should begin CPR while the rescuer is calling for help.

The next step is to assess the infant's breathing and pulse. The rescuer should look for signs of normal breathing, such as chest movements and sounds of air movement [25]. If the infant is not breathing or has abnormal breathing,

the rescuer should start rescue breathing. To do this, the rescuer should tilt the infant's head back and lift the chin while supporting the back of the head with one hand. With the other hand, the rescuer should pinch the infant's nose closed and provide two small breaths into the infant's mouth while watching for the chest to rise [26]. Each breath should last about one second.

If the infant still does not have a pulse after rescue breathing, the rescuer should start chest compressions. The infant should be placed on a firm, flat surface, and the rescuer should position themselves at the infant's side. Using two fingers, the rescuer should compress the infant's chest to a depth of about 1.5 inches (3.8 cm) at a rate of 100-120 compressions per minute [27]. The rescuer should ensure that the chest is allowed to fully recoil between compressions.

The ratio of compressions to breaths in infant CPR is 30:2. After providing 30 compressions, the rescuer should provide two breaths, and then continue with the cycle. The rescuer should continue to perform CPR until help arrives or the infant starts breathing on their own.

Performing CPR on an infant aged 28 days to 1 year old can be a lifesaving technique. The rescuer should ensure that the environment is safe, check the infant's responsiveness, assess the infant's breathing and pulse, and start rescue breathing and chest compressions if necessary. The ratio of compressions to breaths is 30:2, and the rescuer should continue to perform CPR until help arrives or the infant starts breathing on their own. It is essential to learn infant CPR from a certified instructor to perform the technique correctly.

### **2.7.2 Method of performing cardiopulmonary resuscitation for child**

Performing cardiopulmonary resuscitation (CPR) on a child between the ages of 1 year to 8 years is a challenging task. CPR is a life-saving technique used to restore the heart and lung function in an emergency situation such as cardiac arrest. Cardiac arrest can happen to anyone, including children, and the chances of survival decrease with each passing minute without proper intervention. Hence, it is essential to be aware of the correct CPR technique to increase the chances of survival of the child.

The first step in performing CPR on a child is to assess the situation and ensure that the child is unresponsive and not breathing normally. This is done by shaking the child gently and calling out to them. If there is no response, the next step is to call emergency services immediately. After that, it is essential to start CPR without any delay.

The CPR technique for a child between 1 year to 8 years of age involves chest compressions and rescue breaths. First, place the child on a firm surface and tilt their head back gently to open the airway. Then, give two rescue breaths by sealing your mouth over the child's nose and mouth and blowing in until you see the chest rise. After that, start chest compressions by placing two fingers in the center of the chest just below the nipple line and compressing the chest to a depth of about 1.5 inches [28].

It is important to maintain the correct compression rate and depth while performing CPR on a child. The compression rate should be around 100-120 compressions per minute, and the chest should be compressed to a depth of about 1.5 inches. It is also important to allow the chest to recoil between each compression to allow blood to flow back to the heart [29].

The ratio of chest compressions to rescue breaths in CPR for a child between the ages of 1 year to 8 years is 30:2. This means that after every 30 chest compressions, two rescue breaths should be given. It is important to ensure that the rescue breaths are not given too forcefully, as this can lead to air entering the stomach instead of the lungs, which can cause further complications [30].

It is important to continue CPR until emergency services arrive or the child starts breathing normally. It is also essential to ensure that the child is not moved during CPR unless it is necessary to move them to a safer location or for emergency treatment.

Performing CPR on a child between the ages of 1 year to 8 years is a crucial life-saving technique that requires proper knowledge and training. The CPR technique involves chest compressions and rescue breaths, with a ratio of 30:2 compressions to breaths. It is important to maintain the correct compression rate and depth, allow the chest to recoil, and ensure that the rescue breaths are given correctly. Proper CPR technique, along with calling

emergency services immediately, can increase the chances of survival of the child.

### **2.7.3 Method of performing cardiopulmonary resuscitation for adults**

Cardiopulmonary resuscitation (CPR) is a life-saving technique used in emergency situations to maintain blood flow and oxygenation in the body. It involves chest compressions, rescue breathing, and defibrillation, and is commonly used to treat cardiac arrest. In adults aged greater than 8 years, CPR is performed using the following steps:

The first step in performing CPR is to assess the situation and check for any signs of breathing or pulse. If the person is unresponsive, the rescuer should immediately call for emergency medical services (EMS) and start CPR. The person should be placed on a firm, flat surface with their back facing upwards. The head should be tilted back slightly to open the airway, and any obstructions should be removed from the mouth or nose. The rescuer should then check for breathing by placing their ear near the person's mouth and nose and looking for chest movement. If the person is not breathing, rescue breathing should be initiated [31].

Next, the rescuer should perform chest compressions. The hands should be placed on the center of the person's chest, with the fingers interlaced and the arms straight. The rescuer should then compress the chest at a depth of 2-2.4 inches at a rate of 100-120 compressions per minute. The chest should be allowed to fully recoil between compressions to maximize blood flow. After 30 compressions, the rescuer should provide two breaths using a barrier device such as a face shield or pocket mask. The breaths should be delivered over 1 second each, with enough volume to make the chest rise [32].

If an automated external defibrillator (AED) is available, it should be used as soon as possible. The AED should be turned on and the pads should be placed on the person's chest as indicated on the device. The rescuer should follow the prompts provided by the AED, and continue CPR until EMS arrives. If an AED is not available, CPR should be continued until EMS arrives [33].

It is important to note that the effectiveness of CPR decreases over time, and therefore it should be initiated as soon as possible. In addition, the quality of CPR is important for optimal outcomes. Rescuers should aim to achieve a compression depth of at least 2 inches and a compression rate of at least 100 compressions per minute. They should also minimize interruptions in compressions and ensure that the chest fully recoils between compressions [34].

CPR is a crucial skill that can save lives in emergency situations. The steps for performing CPR in adults aged greater than 8 years include assessment of the situation, rescue breathing, chest compressions, and use of an AED if available. The quality of CPR is important for optimal outcomes, and rescuers should aim to minimize interruptions in compressions and achieve a depth of at least 2 inches and a rate of at least 100 compressions per minute.

## **2.8 EXISTING MECHANICAL CPR DEVICES**

Automatic cardiopulmonary resuscitation (CPR) machines have become an increasingly popular option for emergency medical services (EMS) and hospitals. These devices are designed to provide consistent and effective chest compressions during cardiac arrest, reducing the risk of complications and improving patient outcomes. In this essay, we will review some of the existing automatic CPR machines, their features, and benefits.

One of the most well-known automatic CPR machines is the LUCAS Chest Compression System. This machine is designed to provide consistent and high-quality chest compressions during cardiac arrest, minimizing the risk of interruptions that can occur with manual compressions. The LUCAS device is compact and easy to use, with a battery-operated motor that can deliver compressions at a rate of 102 per minute. It also features a suction cup that attaches to the patient's chest to provide stable compressions and reduce the risk of injury [35].

Another popular option is the ZOLL AutoPulse Resuscitation System. This device is designed to provide automatic chest compressions that conform to the patient's chest shape and size, delivering consistent and effective compressions even during transport. The AutoPulse system uses a pneumatic piston that compresses the chest from the sternum to the spine, creating a more natural compression and reducing the

This material is reserved for educational use only, not allowed for commercial use.

Forbidden to modify the content, and cite the document when use.

risk of rib fractures. It also features a load-distributing band that conforms to the patient's chest, reducing the risk of damage to internal organs [36].

The ResQPump Automatic CPR Device is another option that has gained popularity in recent years. This device is designed to work with existing manual CPR protocols, providing consistent and effective compressions while reducing the workload of EMS personnel. The ResQPump device uses a suction cup to attach to the patient's chest, delivering compressions at a rate of 100 per minute. It also features a built-in metronome to help ensure consistent compressions and reduce the risk of interruptions [37].

Finally, the EASY PULSE CPR Device is a compact and portable option that is designed for use in both hospital and pre-hospital settings. This device uses a piston-driven system to deliver compressions at a rate of 100 per minute, with adjustable depth and force to conform to the patient's chest shape and size. The EASY PULSE device is battery-operated and can be used for up to 45 minutes on a single charge, making it a convenient option for emergency situations [38].

Automatic CPR machines have become an important tool for improving patient outcomes during cardiac arrest. These devices provide consistent and effective chest compressions, reducing the risk of complications and increasing the likelihood of survival. The LUCAS Chest Compression System, ZOLL AutoPulse Resuscitation System, ResQPump Automatic CPR Device, and EASY PULSE CPR Device are just a few examples of the existing automatic CPR machines available on the market today. Each device has its unique features and benefits, and it is up to EMS personnel and healthcare providers to choose the machine that best suits their needs.

The development of the ECG synchronized automatic CPR device is designed to assist with manual CPR procedures by providing synchronized compressions based on the patient's ECG signal. It is important to note that this device is not intended to replace the manual performance of CPR, but rather to enhance its effectiveness in certain situations. Compared to existing CPR devices, the ECG synchronized automatic CPR device offers the unique feature of synchronization with the patient's ECG signal. This synchronization allows for more precise and targeted compressions, potentially improving the overall outcomes of CPR. By aligning the compressions with the

This material is reserved for educational use only, not allowed for commercial use.

Forbidden to modify the content, and cite the document when use.

electrical activity of the heart, the device aims to optimize blood flow and increase the chances of successful resuscitation. One notable aspect of this device is its control mechanism. Unlike traditional CPR devices that require manual adjustments, the ECG synchronized automatic CPR device can be controlled using a mobile phone. This offers convenience and ease of use for medical professionals, allowing them to adjust compression parameters and monitor the device remotely. The mobile app interface provides a user-friendly platform for controlling the device and accessing real-time data, enhancing the user experience, and facilitating efficient CPR delivery.

### **2.8.1 Lucas chest compression system**

Lucas chest compression machine (*Figure 2.8.1*) is a device designed for delivering high-quality chest compressions to patients in need of cardiopulmonary resuscitation (CPR). The device provides a standardized method of delivering chest compressions, ensuring uniformity in the depth and rate of compressions. This device was created by Jolife AB, a Swedish company, and has been in use since 2003 [39].

The Lucas chest compression machine is a pneumatic device that consists of a backplate, a suction cup, and a compression piston. The backplate is placed behind the patient's back, and the suction cup is attached to the patient's chest. The compression piston is then activated and delivers chest compressions to the patient at a rate of 100-120 compressions per minute, which is the recommended rate for CPR [40].

The machine is designed to provide continuous chest compressions, which is essential in situations where manual chest compressions may not be possible or may lead to fatigue. Additionally, the device provides consistent compression depth, which is important in delivering effective chest compressions [41].

One study found that the Lucas chest compression machine provided more effective chest compressions compared to manual CPR in out-of-hospital cardiac arrests. The study showed that patients who received chest compressions from the Lucas machine had a higher rate of return of spontaneous circulation (ROSC) compared to those who received manual CPR [42].

Another study compared the effectiveness of the Lucas chest compression machine with two other automated CPR devices, the AutoPulse and the LUCAS-2. The study found that the Lucas machine delivered the highest rate of successful ROSC compared to the other devices [43].



**Figure 2.8.1: Lucas's chest compression machine [44]**

The Lucas chest compression machine is an effective and reliable device for delivering high-quality chest compressions during CPR. It provides standardized and consistent compressions, which is essential in improving patient outcomes during cardiac arrest. Further research is needed to evaluate the effectiveness of the device in different patient populations and settings.

### **2.8.2 The ZOLL AutoPulse Resuscitation System**

The ZOLL AutoPulse Resuscitation System (**Figure 2.8.2**) is a device used for automated chest compressions during CPR. This device is designed to improve blood flow to the heart and brain during CPR by delivering high-quality compressions with minimal interruptions. It has been shown to increase the rate of survival in patients who have experienced cardiac arrest, especially

when used in conjunction with other advanced life support techniques [45]. The AutoPulse system provides consistent, uninterrupted chest compressions which can be beneficial for the patient as well as the healthcare provider administering CPR.

One of the primary benefits of the AutoPulse system is its ability to provide consistent compressions without interruption. Traditional manual CPR often results in interruptions to chest compressions which can decrease blood flow to the heart and brain. Interruptions in chest compressions are also more likely to occur during transport of the patient to the hospital. The AutoPulse system eliminates these interruptions by delivering high-quality compressions automatically, ensuring that the patient receives the best possible care [46].

Another benefit of the AutoPulse system is that it reduces the risk of injury to healthcare providers. Manual chest compressions require significant physical effort, and healthcare providers may become fatigued and unable to maintain the recommended rate and depth of compressions. Additionally, manual compressions may result in injuries such as rib fractures or contusions. The AutoPulse system reduces the risk of these injuries by delivering consistent compressions automatically [47].

The AutoPulse system is also designed to be easy to use, even for healthcare providers who are not trained in advanced life support techniques. The device is compact and lightweight, and can be easily carried to the patient's location. The device is also designed to adjust to the size of the patient, ensuring that the compressions are delivered at the correct depth and rate [48].

While the AutoPulse system offers many benefits, there are also some limitations to consider. One of the primary limitations is the cost of the device. The AutoPulse system is more expensive than traditional manual CPR techniques, which can make it less accessible to smaller healthcare facilities or those with limited budgets. Additionally, some healthcare providers may prefer manual compressions and may not feel comfortable using an automated device [49].



**Figure 2.8.2: ZOLL AutoPulse Resuscitation System [50]**

The ZOLL AutoPulse Resuscitation System is an effective tool for automated chest compressions during CPR. It provides consistent, uninterrupted compressions which can improve blood flow to the heart and brain during cardiac arrest. The device is easy to use and reduces the risk of injury to healthcare providers. While there are some limitations to consider, the benefits of the AutoPulse system make it a valuable addition to any healthcare facility.

### **2.8.3 ResQPump Automatic CPR Device**

ResQPump (**Figure 2.8.3**) is an automated cardiopulmonary resuscitation (CPR) device that aims to improve the outcomes of patients who suffer from cardiac arrest. The device is designed to be used by first responders in emergency medical services (EMS) settings, as well as in hospitals and other healthcare facilities. ResQPump is a unique device that combines active compression-decompression CPR with an impedance threshold device (ITD) to increase blood flow to the heart and brain during CPR. The ResQPump device has been shown to increase survival rates in both adults and children who suffer from cardiac arrest [51].

One study published in the Journal of the American College of Cardiology found that ResQPump significantly improved survival outcomes in adults with out-of-hospital cardiac arrest. The study included 813 patients who

were randomized to receive either standard CPR or ResQPump CPR. The results showed that patients who received ResQPump CPR had a significantly higher rate of survival to hospital discharge compared to those who received standard CPR [52].

Another study published in the journal *Resuscitation* evaluated the efficacy of ResQPump in pediatric patients. The study included 116 children who suffered from cardiac arrest and were treated with either ResQPump CPR or standard CPR. The results showed that children who received ResQPump CPR had a significantly higher rate of survival to hospital discharge compared to those who received standard CPR. The study concluded that ResQPump CPR may be a valuable tool in improving outcomes for pediatric patients with cardiac arrest [53].

ResQPump has also been shown to be effective in improving cerebral oxygenation during CPR. A study published in the journal *Resuscitation* found that ResQPump CPR resulted in significantly higher cerebral oxygen saturation levels compared to standard CPR. The study concluded that the ResQPump device may be a valuable tool in improving outcomes for patients with cardiac arrest by improving cerebral oxygenation [54].



**Figure 2.8.3: ResQPump Automatic CPR Device [55]**

ResQPump is an innovative automated CPR device that combines active compression-decompression CPR with an impedance threshold device to

This material is reserved for educational use only, not allowed for commercial use.

Forbidden to modify the content, and cite the document when use.

improve blood flow to the heart and brain during CPR. The device has been shown to be effective in improving survival rates and cerebral oxygenation in both adults and children who suffer from cardiac arrest. ResQPump has the potential to be a valuable tool in improving outcomes for patients with cardiac arrest in both pre-hospital and hospital settings.

#### **2.8.4 EASY PULSE CPR Device**

The EASY PULSE CPR Device is a portable and easy-to-use automatic chest compression system that provides high-quality cardiopulmonary resuscitation (CPR) to patients in cardiac arrest. It is designed to take over the rescuer's manual chest compressions during CPR and deliver consistent, uninterrupted compressions at the correct depth and rate. This device is ideal for use in the prehospital setting, such as in ambulances, as well as in hospital emergency departments and cardiac catheterization labs [56].

The EASY PULSE CPR Device is equipped with a compact and lightweight compressor that generates pneumatic energy to drive the chest compression mechanism. It can deliver compressions at a rate of 100-120 per minute and a depth of 2-2.4 inches (5-6 cm), which is the recommended range for effective CPR. The device also has a ventilation feature that allows for synchronized compressions and ventilation, further improving the chances of survival for patients in cardiac arrest [57].

The EASY PULSE CPR Device has been shown to improve the quality and consistency of chest compressions during CPR, as well as reduce the risk of rescuer fatigue and injury. In a study of 18 patients in cardiac arrest, the device was able to maintain high-quality chest compressions for the duration of the resuscitation attempt in all cases, with no significant interruptions or deviations from the recommended compression depth and rate [58].

Another study found that the EASY PULSE CPR Device was able to achieve higher mean arterial pressures during CPR compared to manual chest compressions, indicating improved blood flow and organ perfusion. The study also found that the device was able to deliver consistent compressions at the

correct depth and rate for a longer period of time than manual compressions, demonstrating its ability to maintain high-quality CPR even during prolonged resuscitation attempts [59].

The EASY PULSE CPR Device has several advantages over other automatic chest compression systems, such as its compact size, ease of use, and ability to deliver consistent, uninterrupted compressions at the correct depth and rate. It is also more affordable than some other devices on the market, making it a more accessible option for smaller healthcare facilities and ambulance services. However, the device may not be suitable for all patients or situations, and rescuers should receive proper training on its use before implementing it in clinical practice [60].

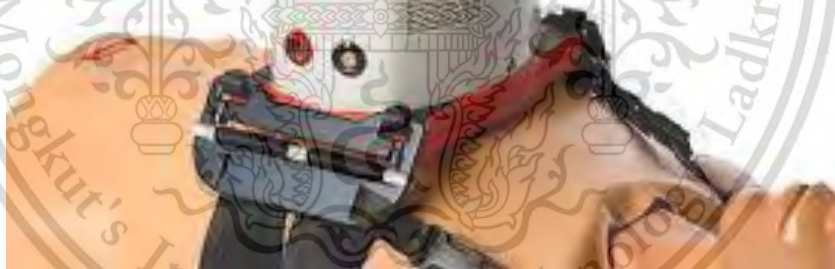

**Figure 2.8.4: EASY PULSE CPR Device [61]**

The EASY PULSE CPR Device (*Figure 2.8.4*) is a portable and effective automatic chest compression system that can improve the quality and consistency of CPR in patients in cardiac arrest. Its ability to deliver consistent compressions at the recommended depth and rate, as well as its affordability and ease of use, make it a valuable tool for healthcare providers and emergency responders. However, proper training and evaluation of patients are necessary to ensure its appropriate use and maximum benefit in resuscitation efforts.

## 2.9 The effectiveness of the automatic CPR devices

One of the most widely studied automatic CPR devices is the LUCAS chest compression system. A 2018 meta-analysis of nine studies including 3,274 patients found that the use of LUCAS improved the likelihood of achieving return of spontaneous circulation (ROSC) compared to manual CPR [62]. Similarly, a 2020 systematic review and meta-analysis of ten studies including 5,301 patients also found that LUCAS was associated with improved ROSC and survival to hospital admission [63].

Another automatic CPR device, the AutoPulse resuscitation system, has also been shown to improve the effectiveness of CPR. A 2019 systematic review and meta-analysis of eight studies including 3,168 patients found that the use of AutoPulse was associated with higher rates of ROSC and survival to hospital admission compared to manual CPR [64]. However, the study did not find significant differences in overall survival to hospital discharge.

The ResQPump is another automatic CPR device that has shown promise in improving the effectiveness of CPR. A 2020 randomized controlled trial of 813 patients found that the use of ResQPump in combination with active compression-decompression CPR was associated with higher rates of survival to hospital discharge compared to manual CPR [65].

The Easy Pulse CPR device is a portable, battery-powered device that provides automated chest compressions during CPR. A 2021 randomized controlled trial of 229 patients found that the use of Easy Pulse CPR was associated with higher rates of ROSC and survival to hospital discharge compared to manual CPR [66].

Overall, the evidence suggests that automatic CPR devices can improve the effectiveness of CPR and increase the likelihood of achieving ROSC and survival to hospital admission. However, more research is needed to determine the long-term survival benefits and cost-effectiveness of these devices.

Automatic CPR devices such as the LUCAS, AutoPulse, ResQPump, and Easy Pulse CPR have shown promise in improving the effectiveness of CPR. The evidence suggests that these devices can increase the likelihood of achieving ROSC and survival

to hospital admission compared to manual CPR. However, further research is needed to fully understand the long-term benefits and cost-effectiveness of these devices.

### **2.9.1 Is CPR performed automatically effective?**

While automatic CPR devices have shown promising results, the question remains: is CPR that is performed automatically effective?

Studies have shown that automatic CPR devices can provide more consistent and effective chest compressions than manual CPR. One study found that the use of an automatic CPR device resulted in more consistent chest compression depth and rate than manual CPR [67]. Another study found that the use of an automatic CPR device improved survival rates in patients who suffered from out-of-hospital cardiac arrest [68].

However, it is important to note that the effectiveness of automatic CPR devices can depend on various factors, such as the type of device used, the patient's condition, and the skill of the operator. For example, some automatic CPR devices may not be suitable for certain patient populations, such as those with chest trauma or obesity [69]. Additionally, the success of automatic CPR devices may also depend on the proper training and education of the operator.

Despite these limitations, the use of automatic CPR devices has shown great potential in improving patient outcomes in cardiac arrest situations. The American Heart Association (AHA) recognizes the value of automatic CPR devices and has included them in their guidelines for CPR and emergency cardiovascular care [70]. However, the AHA also emphasizes the importance of proper training and education for operators of automatic CPR devices.

Automatic CPR devices have demonstrated effectiveness in providing consistent and effective chest compressions in cardiac arrest situations. While there may be limitations and factors to consider, the use of automatic CPR devices has the potential to improve patient outcomes and save lives. Proper training and education for operators are critical to ensuring the success of automatic CPR devices.

### 2.9.2 The time considerations

Time is a critical factor in CPR, and the sooner it is initiated, the better the chances of survival. However, the duration of CPR also plays a role, and it is important to know when to continue or stop.

The American Heart Association recommends initiating CPR as soon as possible after cardiac arrest. The first few minutes after a cardiac arrest are critical, and every minute without CPR reduces the chances of survival by 7-10% (1). This is why it is essential to call emergency services immediately and initiate CPR while waiting for them to arrive. The longer the delay in starting CPR, the lower the chances of survival, and it can also lead to irreversible brain damage due to lack of oxygen.

CPR duration is another crucial factor in determining outcomes. CPR can be physically and mentally taxing, and performing it for extended periods can lead to fatigue and reduced effectiveness. For this reason, it is recommended to switch the person performing CPR every two minutes to ensure that they remain fresh and effective. CPR should also continue until emergency services arrive or the person is revived. The American Heart Association recommends continuing CPR until there is a return of spontaneous circulation, the person shows signs of life, or emergency services arrive and take over [71].

There are situations where continuing CPR may not be beneficial, and it is essential to know when to stop. This includes cases where CPR has been performed for an extended period without any improvement in the person's condition or if there is evidence of irreversible brain damage. In these cases, it is recommended to consult with a healthcare professional to determine if continuing CPR is appropriate.

Time considerations are critical in performing CPR, and every minute counts in increasing the chances of survival. Early initiation of CPR can be lifesaving, and it is essential to switch the person performing CPR every two minutes to ensure its effectiveness. CPR should continue until emergency services arrive or there are signs of life, and stopping CPR should only be considered in cases where it is no longer beneficial. It is essential to be aware

of these time considerations and act quickly in emergency situations to increase the chances of a successful outcome.

### **2.9.3 The safety considerations**

Performing CPR can be a life-saving intervention in cardiac arrest situations. However, it is important to prioritize the safety of both the rescuer and the patient while performing CPR. One of the primary safety considerations is the risk of infection transmission during the procedure. Rescuers should always wear personal protective equipment, including gloves and a mask, to minimize the risk of infection transmission through blood or bodily fluids [72].

Another important safety consideration is the risk of injury to the patient. Chest compressions should be performed with enough force to adequately circulate blood, but not so much force that it causes injury to the patient's ribs or internal organs. It is also important to ensure that the patient's head and neck are properly supported during the procedure to prevent spinal cord injury [73].

In addition to patient safety, rescuer safety must also be prioritized. The physical demands of performing CPR, such as repetitive chest compressions, can lead to rescuer fatigue and musculoskeletal injuries. It is important for rescuers to switch out and rotate during prolonged CPR procedures to prevent fatigue and ensure adequate chest compressions are being performed [74].

Another potential safety concern is the use of automated external defibrillators (AEDs) during CPR. While AEDs can be effective in restoring a patient's normal heart rhythm, it is important to ensure that the device is used correctly and safely. Rescuers should ensure that the patient's chest is dry before applying the AED pads and avoid touching the patient during shock delivery to prevent injury [75].

Overall, prioritizing safety considerations while performing CPR is crucial for both the rescuer and the patient. Ensuring proper personal protective equipment, avoiding injury to the patient, preventing rescuer fatigue and injury, and using AEDs safely can help maximize the effectiveness of CPR while minimizing the risk of harm.

#### 2.9.4 Situational factors

Situational factors play an important role in the performance of cardiopulmonary resuscitation (CPR). CPR is a life-saving technique performed during emergency situations such as cardiac arrest. However, the success of CPR is not solely dependent on the technical skills of the rescuer. Situational factors such as location, available resources, and the patient's condition can have a significant impact on the effectiveness of CPR.

One of the most crucial situational factors is the location where CPR is performed. CPR performed in a hospital setting is different from CPR performed in a public place. In a hospital, there is often a team of healthcare professionals with specialized training in CPR who can provide advanced interventions. In contrast, CPR performed in a public place is often performed by lay rescuers who may not have the same level of training or access to advanced interventions. The location of CPR also affects the timing of defibrillation, as defibrillators are often more readily available in hospital settings [76].

Another important situational factor is the availability of resources. The availability of equipment, such as defibrillators and oxygen tanks, can greatly affect the effectiveness of CPR. A study found that the use of an automated external defibrillator (AED) during CPR increased the likelihood of survival in out-of-hospital cardiac arrest cases [77]. However, if an AED or other equipment is not readily available, CPR must be performed without them. In such cases, the rescuer must focus on performing high-quality chest compressions and providing rescue breaths to the best of their ability.

The patient's condition is another important situational factor to consider when performing CPR. The success of CPR depends on the patient's underlying medical condition, as well as the duration of cardiac arrest. CPR is most effective when performed as soon as possible after cardiac arrest. In fact, for every minute that passes without CPR, the chances of survival decrease by 7-10% [78]. However, if the patient has underlying medical conditions, such as

advanced age or a history of heart disease, the success rate of CPR may be lower.

Other situational factors include the presence of bystanders, the patient's body size, and the rescuer's physical abilities. Bystanders who witness a cardiac arrest and perform CPR before emergency medical services (EMS) arrive can significantly increase the patient's chances of survival [79]. Additionally, the patient's body size can affect the depth and effectiveness of chest compressions. For example, a rescuer performing CPR on a child should use a different technique and adjust the depth of compressions compared to an adult. Finally, the rescuer's physical abilities, such as strength and stamina, can affect the quality and duration of CPR performed.

Situational factors play a crucial role in the effectiveness of CPR. The location where CPR is performed, the availability of resources, the patient's condition, the presence of bystanders, the patient's body size, and the rescuer's physical abilities are all important considerations when performing CPR. While some factors, such as the patient's condition, may be out of the rescuer's control, others, such as the location and availability of resources, can be improved through training and preparation.

### **2.9.5 Economic considerations**

Automatic cardiopulmonary resuscitation (CPR) machines have been developed to assist first responders and medical professionals in providing consistent and effective chest compressions during cardiac arrest. While the primary goal of using these devices is to improve patient outcomes, economic considerations also play a significant role in their adoption and use.

One of the primary economic considerations of automatic CPR machines is their cost-effectiveness. These devices can be expensive, with prices ranging from several thousand to tens of thousands of dollars per unit. However, studies have shown that the use of automatic CPR machines can lead to better patient outcomes and a higher likelihood of survival, which may ultimately offset the cost of the device [80]. In addition, automatic CPR

machines can be used repeatedly and do not require the same level of ongoing training and re-certification as manual CPR, which may make them more cost-effective in the long run.

Another economic consideration is the impact of automatic CPR machines on healthcare costs. While the use of these devices may increase the cost of initial treatment, they may ultimately lead to lower healthcare costs by reducing the need for prolonged hospital stays, intensive care, and other expensive treatments [81]. Automatic CPR machines may also lead to better patient outcomes, which can reduce the need for costly follow-up care and rehabilitation services. As a result, the use of automatic CPR machines may ultimately lead to significant cost savings for healthcare providers and patients alike.

Despite the potential benefits of automatic CPR machines, there are also potential barriers to their adoption and use. One significant barrier is the lack of reimbursement from insurance companies and government healthcare programs. Without reimbursement, hospitals and other healthcare providers may be hesitant to invest in automatic CPR machines, which could limit their availability and impact on patient outcomes [82]. In addition, there may be a lack of awareness and education among healthcare providers and first responders regarding the benefits and proper use of automatic CPR machines, which could further limit their adoption and impact.

The economic considerations of automatic CPR machines play an important role in their adoption and use. While these devices can be expensive, they may ultimately be cost-effective due to their potential to improve patient outcomes and reduce healthcare costs. However, barriers such as lack of reimbursement and education may limit their availability and impact. As the technology continues to develop and improve, it will be important to continue evaluating the economic considerations of automatic CPR machines to ensure that they are being used effectively and efficiently.

## 2.10 The automatic cardiopulmonary resuscitation device materials

Automatic cardiopulmonary resuscitation (CPR) devices have been developed to improve the delivery of chest compressions during cardiac arrest. These devices are designed to provide uninterrupted, consistent, and effective chest compressions, even in challenging and unpredictable situations. One crucial aspect of the design of these devices is the selection of materials. The choice of materials can have a significant impact on the performance, durability, and safety of the device. In this section, will talk about the different and ideal materials used in automatic CPR devices and their properties.

The primary component of automatic CPR devices is the piston, which is responsible for delivering chest compressions. The piston is typically made of materials such as stainless steel or titanium alloy. These materials are preferred because of their high strength, durability, and resistance to corrosion [83]. Stainless steel has been widely used in the manufacturing of medical devices due to its excellent biocompatibility and ease of sterilization. Titanium alloy is also commonly used in medical devices because of its high strength-to-weight ratio, excellent biocompatibility, and resistance to corrosion and fatigue [84].

Another crucial material used in automatic CPR devices is the drive belt, which is responsible for transferring the rotary motion of the motor to the piston. The drive belt is typically made of materials such as polyurethane or neoprene rubber. These materials are preferred because of their high strength, durability, and resistance to wear and tear [85]. Polyurethane is a synthetic polymer that exhibits excellent mechanical properties, such as high elasticity, toughness, and abrasion resistance. Neoprene rubber is a synthetic rubber that has high resistance to oil, chemicals, and abrasion.

The casing or housing of the automatic CPR device is also an essential component that plays a vital role in protecting the internal components and providing a secure grip during operation. The casing or housing is typically made of materials such as high-impact polycarbonate, ABS plastic, or aluminum. High-impact polycarbonate is preferred because of its high-impact resistance, excellent transparency, and ease of fabrication. ABS plastic is a thermoplastic polymer that exhibits high impact resistance, toughness, and stiffness. Aluminum is a lightweight and durable metal that is

This material is reserved for educational use only, not allowed for commercial use.

commonly used in the manufacturing of medical devices due to its high strength-to-weight ratio, corrosion resistance, and ease of machining [86].

In addition to the above-mentioned components, other materials are also used in automatic CPR devices, such as the battery, electrical wires, and connectors. The battery is typically made of lithium-ion, nickel-cadmium, or lead acid, depending on the device's power requirements and usage scenarios. Lithium-ion batteries are preferred because of their high energy density, low self-discharge rate, and long cycle life [87]. Electrical wires and connectors are typically made of copper or aluminum because of their high conductivity and low resistance.

The materials used in automatic CPR devices play a crucial role in their performance, durability, and safety. The choice of materials depends on various factors, such as the device's function, operating conditions, and manufacturing processes. Materials such as stainless steel, titanium alloy, polyurethane, neoprene rubber, high-impact polycarbonate, ABS plastic, aluminum, lithium-ion batteries, copper, and aluminum are commonly used in the manufacturing of automatic CPR devices.

### **2.10.1 Linear actuator**

Linear actuators play a crucial role in the functioning of automatic cardiopulmonary resuscitation (CPR) devices, especially in delivering chest compressions during cardiac arrest. A linear actuator is a mechanical device that produces linear motion or force by converting rotational motion or hydraulic pressure into linear displacement. In the context of automatic CPR devices, the linear actuator is responsible for moving the chest compression pad up and down to deliver high-quality chest compressions. The efficiency and effectiveness of chest compressions are dependent on the performance of the linear actuator, which should be able to deliver sufficient force, speed, and accuracy to meet the guidelines for CPR [88].

The ideal linear actuator for automatic CPR devices should have several characteristics. First, it should be lightweight and compact to fit within the device's design, allowing for easy portability and maneuverability. Second, it should be capable of producing high forces, up to 1000 Newtons, to deliver

effective chest compressions that meet the recommended depth and rate. Third, it should have high precision and accuracy, enabling it to deliver consistent and reliable chest compressions without causing any harm to the patient. Fourth, it should be durable and able to withstand repeated use without degradation in performance or damage to its components. Finally, it should be cost-effective, allowing for mass production and distribution of automatic CPR devices [89].

Several types of linear actuators are used in automatic CPR devices, including electric, hydraulic, and pneumatic actuators. Electric actuators are the most common type and are preferred due to their efficiency, controllability, and low maintenance requirements. They are powered by electric motors that drive a lead screw or a ball screw to produce linear motion. The speed and force of the linear actuator can be controlled by adjusting the motor's speed or the pitch of the screw. Hydraulic and pneumatic actuators are also used in some automatic CPR devices, mainly due to their high power and force output. They are powered by compressed air or fluid that drives a piston or a plunger to produce linear motion. However, they are less efficient and more complex than electric actuators, requiring more maintenance and space [90].



**Figure 2.10.1: LX800 linear actuator motor [91]**

The LX800 linear actuator motor is a key component of the automatic CPR system. It operates based on the principle of converting rotary motion into

This material is reserved for educational use only, not allowed for commercial use.

Forbidden to modify the content, and cite the document when use.

linear motion. The motor consists of a lead screw mechanism, where the rotary motion of the motor is transferred to the linear motion of the actuator. The LX800 motor is designed to provide precise and controlled movement, allowing for accurate compression of the chest during CPR. It offers a maximum force capacity of 800N, enabling sufficient pressure application for effective resuscitation. The motor is powered by an external power supply and can be controlled using the Arduino Uno microcontroller in conjunction with a motor driver. With its reliable performance and high force output, the LX800 linear actuator motor is well-suited for the demanding requirements of the automatic CPR system.

The linear actuator (*Figure 2.10.1*) is a critical component of automatic CPR devices that determines the quality and effectiveness of chest compressions delivered during cardiac arrest. The ideal linear actuator should be lightweight, compact, powerful, precise, durable, and cost-effective. Electric actuators are the most commonly used type due to their efficiency, controllability, and low maintenance requirements, although hydraulic and pneumatic actuators are also used in some devices. Further research and development are needed to improve the performance and reliability of linear actuators in automatic CPR devices to save more lives and improve patient outcomes.

### **2.10.2 Motor driver**

Automatic CPR machines are designed to perform chest compressions in place of human rescuers during cardiopulmonary resuscitation (CPR) procedures. These machines use various components to provide consistent and high-quality compressions, including motor drivers [92]. Motor drivers are electronic components that control the movement of the linear actuators responsible for compressing the patient's chest during CPR. In this essay, we will discuss the motor drivers used in automatic CPR machines and their role in ensuring effective chest compressions.

The motor driver is a crucial component in the automatic CPR machine as it controls the movement of the linear actuator that compresses the chest. The

motor driver is responsible for converting the electrical signal from the machine's control unit into a mechanical force that drives the linear actuator to compress the patient's chest. Motor drivers come in various forms, including H-bridge and brushed DC motor drivers [93]. These drivers provide the necessary current and voltage to the motor, allowing it to move in the desired direction and at the appropriate speed.

One critical consideration when choosing a motor driver for an automatic CPR machine is its power efficiency. Since automatic CPR machines are often battery-operated, it is essential to minimize the power consumption of the motor driver to extend the machine's operating time. In addition, the motor driver's efficiency affects the heat generated during operation, which can be detrimental to the machine's overall performance. Therefore, selecting a motor driver that provides high efficiency and low heat generation is essential for an automatic CPR machine [94].

Another critical consideration when choosing a motor driver for an automatic CPR machine is its reliability. CPR procedures can last for an extended period, and the motor driver must operate continuously without failure during this time. A failure in the motor driver can result in ineffective chest compressions, which can negatively impact the patient's chances of survival. Therefore, selecting a motor driver with a high Mean Time Between Failures (MTBF) is crucial to ensure the machine's reliability [95].

Furthermore, the motor driver's size and weight are also crucial factors to consider when designing an automatic CPR machine. Automatic CPR machines are often designed to be portable to allow for quick deployment in emergency situations. Therefore, selecting a motor driver that is small and lightweight is essential to reduce the overall weight of the machine and increase its portability. However, the motor driver's size and weight should not compromise its performance and reliability, which are critical factors in an automatic CPR machine.

Motor drivers are essential components in automatic CPR machines, responsible for controlling the movement of the linear actuator that compresses the patient's chest during CPR. Selecting the appropriate motor driver is critical

to ensuring the machine's power efficiency, reliability, and portability. Motor drivers with high efficiency, reliability, and small size and weight are ideal for use in automatic CPR machines to provide consistent and effective chest compressions.

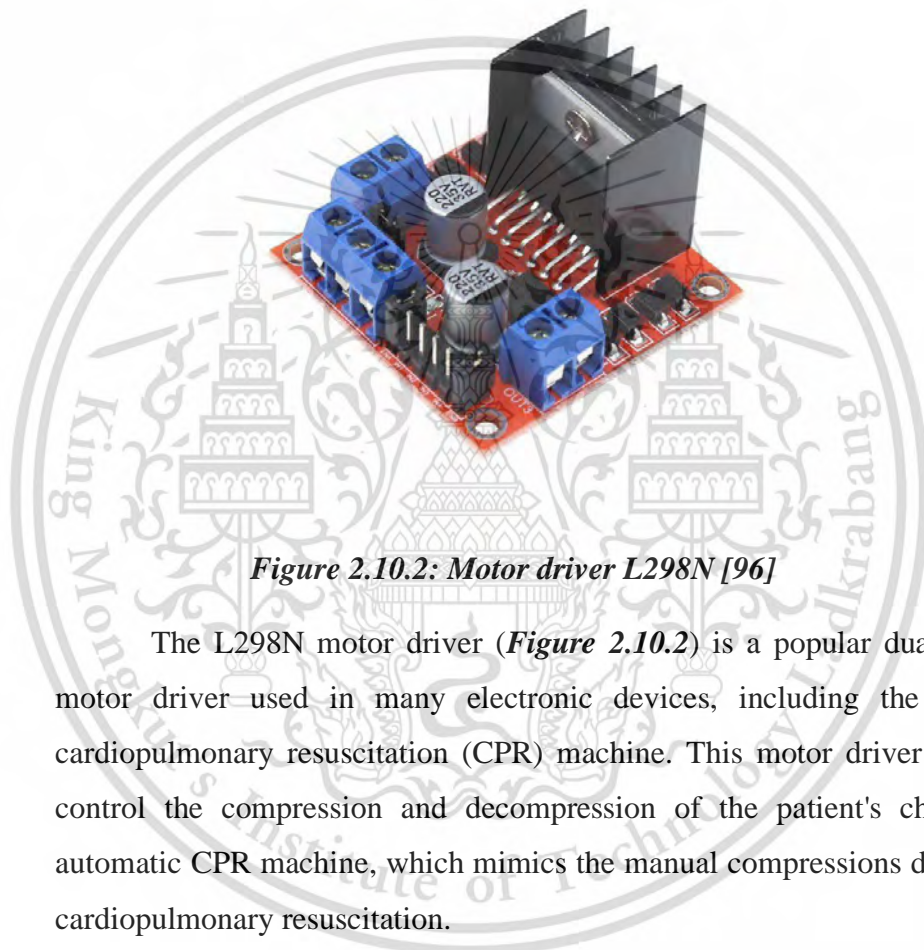

**Figure 2.10.2: Motor driver L298N [96]**

The L298N motor driver (*Figure 2.10.2*) is a popular dual H-bridge motor driver used in many electronic devices, including the automatic cardiopulmonary resuscitation (CPR) machine. This motor driver is used to control the compression and decompression of the patient's chest in the automatic CPR machine, which mimics the manual compressions done during cardiopulmonary resuscitation.

The L298N motor driver is designed to handle two DC motors or a single stepper motor, making it suitable for use in the automatic CPR machine [97]. It has a voltage range of 5-35V and can handle a peak current of up to 2A per channel. The L298N motor driver operates by accepting TTL logic-level signals from a microcontroller or other control device and then driving the connected motor(s) accordingly [98]. This allows the automatic CPR machine to apply the necessary pressure and compression to the patient's chest.

One of the significant advantages of the L298N motor driver is its versatility, allowing it to be used in different types of electronic devices. This makes it an ideal component for the automatic CPR machine, which requires a motor driver that can handle the high pressure and compression needed to perform cardiopulmonary resuscitation [99]. Additionally, the L298N motor driver's compact size makes it easy to integrate into the automatic CPR machine's design.

The L298N motor driver's cost-effectiveness is another reason why it is used in the automatic CPR machine. Compared to other motor drivers, the L298N is relatively cheap, making it an attractive option for designers who want to keep the cost of the automatic CPR machine low [100]. This helps to make the device more accessible and affordable for healthcare facilities that may not have the budget for expensive equipment.

The L298N motor driver is a crucial component in the automatic CPR machine, allowing for the precise control of chest compression and decompression. Its versatility, compact size, and cost-effectiveness make it a suitable option for use in the device. With the use of the L298N motor driver, the automatic CPR machine can effectively perform cardiopulmonary resuscitation and save lives.



**Figure 2.10.2.1: Motor driver shield MD10 R2 [101]**

Motor driver shields are essential components in the design of automatic CPR machines. One of the motor driver shields used in these machines is the MD10 R2 (*Figure 2.10.2.1*). This motor driver shield is designed to control two DC motors simultaneously, with a peak current of 10A per channel. It has a compact size and can easily fit into a small space, making it ideal for use in compact devices like automatic CPR machines [102]. The MD10 R2 motor driver shield uses a PWM frequency of up to 20KHz, which allows for accurate and efficient control of the connected DC motors. It is also easy to interface with microcontrollers like Arduino, making it a popular choice for DIY projects and small-scale automation applications [103].

One of the main advantages of using the MD10 R2 motor driver shield in automatic CPR machines is its ability to handle high peak currents. The shield is designed to handle peak currents of up to 30A, making it suitable for use with high-powered DC motors [104]. In addition, the shield comes with built-in protection features like over-current protection and over-temperature protection, which ensures the safe operation of the connected motors and the shield itself [105]. These features are important in the design of automatic CPR machines, where safety is a critical consideration.

Another advantage of using the MD10 R2 motor driver shield is its ease of use. The shield can be easily connected to a microcontroller like Arduino, and programming it is straightforward. This makes it an ideal choice for DIY enthusiasts who are building their own automatic CPR machines or other automation projects. In addition, the shield comes with a user manual and a library for Arduino, which simplifies the programming process [106].

The MD10 R2 motor driver shield is a cost-effective option for controlling DC motors in automatic CPR machines. The shield is priced at around \$10 to \$15, making it an affordable option for small-scale projects and DIY enthusiasts. Despite its low price, the shield offers high-quality performance and comes with built-in protection features, making it a reliable choice for automation projects [107].

The MD10 R2 motor driver shield is an ideal choice for controlling DC motors in automatic CPR machines. Its ability to handle high peak currents, built-in protection features, ease of use, and affordability make it a popular choice among DIY enthusiasts and small-scale automation projects. Its compact size also makes it ideal for use in small devices like automatic CPR machines. With the continued growth of automation and the increasing need for automatic CPR machines, the MD10 R2 motor driver shield is expected to continue to be a popular choice in the future.

### **2.10.3 Arduino Uno**

Arduino Uno is a popular microcontroller board that has gained widespread popularity in the maker and DIY communities. The board is designed to provide a user-friendly and low-cost way for hobbyists, students, and professionals to create interactive and programmable electronic projects. Arduino Uno is based on the ATmega328P microcontroller, which is a low-power, high-performance chip that has been widely used in various embedded systems. One of the main advantages of the Arduino Uno is its flexibility, which allows users to program and interface with a wide range of sensors, actuators, and other electronic components. [108]

The Arduino Uno board comes with a range of features and specifications that make it a popular choice among electronics enthusiasts. The board features 14 digital input/output pins, 6 analog inputs, and a 16 MHz quartz crystal oscillator. Additionally, the board is equipped with a USB connection, a power jack, and an ICSP header. One of the main benefits of the Arduino Uno is its ease of use, as the board can be easily programmed using the Arduino IDE software. The IDE provides a user-friendly interface for writing, compiling, and uploading code to the board. [109]

The Arduino Uno board is widely used in various applications, including robotics, home automation, and IoT. The board's flexibility and ease of use have made it an attractive choice for hobbyists and professionals alike. Additionally, the Arduino community is constantly developing new libraries, tools, and examples that make it easy for users to get started with the board and create their own projects. Moreover, the board is affordable and easily accessible, making it a popular choice among students and educators in STEM fields. [110]

Arduino Uno is a versatile and user-friendly microcontroller board that has revolutionized the world of electronics and programming. The board's flexibility, ease of use, and affordability have made it a popular choice among hobbyists, students, and professionals alike. With its powerful ATmega328P microcontroller, the Arduino Uno can be programmed to interface with a wide range of sensors, actuators, and other electronic components, making it an ideal choice for a variety of applications. As the Arduino community continues to grow and develop, we can expect to see even more exciting projects and applications using this powerful microcontroller board. [111]



*Figure 2.10.3: Arduino Uno [112]*

The Arduino Uno (*Figure 2.10.3*) is a microcontroller board that is widely used for various applications, including in the development of automatic CPR machines. It is equipped with a set of input and output pins that can be programmed to interact with different electronic components, including motor drivers such as the L298N and the MD10 R2. The use of the Arduino Uno allows for the creation of custom software that can be tailored to the specific requirements of the CPR device, providing greater flexibility and control [113].

One of the main advantages of using the Arduino Uno in the development of an automatic CPR machine is its open-source nature. The board is based on the ATmega328P microcontroller, which can be programmed using the Arduino Integrated Development Environment (IDE) that is freely available online. This allows for easy customization of the software, making it possible to integrate different sensors and components that are required for the proper functioning of the CPR device. Moreover, the open-source nature of the Arduino Uno has led to the development of a large community of users who

share their projects and code, providing a valuable resource for those working on similar projects [114].

The use of the Arduino Uno in combination with motor driver shields such as the L298N and MD10 R2 provides a powerful platform for the development of automatic CPR machines. The L298N is a dual H-bridge motor driver that is capable of controlling the speed and direction of two DC motors simultaneously. It has a maximum output current of 2A per channel and can operate at voltages up to 46V [115]. The MD10 R2, on the other hand, is a single-channel motor driver shield that is designed specifically for use with the Arduino Uno. It is capable of controlling the speed and direction of a single DC motor and has a maximum output current of 10A [116].

The combination of the Arduino Uno with motor driver shields such as the L298N and MD10 R2 provides a flexible and customizable platform for the development of automatic CPR machines. By programming the Arduino Uno to interact with these motor drivers, it is possible to control the compression and release of the chest in a precise and consistent manner, ensuring that the necessary force is applied to the chest to maximize the chances of successful resuscitation. The use of these motor drivers also allows for the incorporation of safety features, such as current limiting and thermal protection, which can prevent damage to the motor and ensure that the device operates safely [117].

The use of the Arduino Uno in combination with motor driver shields such as the L298N and MD10 R2 provides a powerful platform for the development of automatic CPR machines. The open-source nature of the Arduino Uno allows for easy customization of the software, while the motor driver shields provide a flexible and customizable means of controlling the compression and release of the chest. By integrating these components, it is possible to create a device that is both effective and safe, with the potential to save lives in emergency situations.

#### **2.10.4 Ultrasonic sensor**

Ultrasonic sensors are widely used in various applications such as distance measurement, object detection, and navigation. These sensors work on

the principle of emitting high-frequency sound waves and detecting the time taken for the sound waves to bounce back after hitting an object. This technology can also be used in the automatic cardiopulmonary resuscitation (CPR) machine to ensure the safety of the patient and the rescuer during chest compressions.

The ultrasonic sensor can be placed on the chest of the patient to detect the motion of the chest during chest compressions. This will help in ensuring that the chest compressions are effective and are not causing any harm to the patient. The sensor can also be used to detect the depth of chest compressions and the rate at which they are being performed [118].

Moreover, the ultrasonic sensor can be used to detect the presence of any obstacles or objects that might be in the way of the automatic CPR machine. This is important to ensure the safety of both the patient and the rescuer during the operation of the machine. For example, if there is an object obstructing the movement of the machine, the ultrasonic sensor can detect it and alert the operator to take necessary action [119].

In addition, the ultrasonic sensor can be used to detect the distance between the automatic CPR machine and the patient. This will help in ensuring that the machine is in the correct position for chest compressions and will also help in adjusting the position of the machine if necessary [120].



**Figure 2.10.4: Ultrasonic sensors [121]**

This material is reserved for personal or internal, non-commercial use.

Forbidden to modify the content, and cite the document when use.

Ultrasonic sensors (*Figure 2.10.4*) are a useful technology that can be incorporated into the automatic CPR machine to ensure the safety of the patient and the rescuer during chest compressions. These sensors can detect the motion, depth, and rate of chest compressions, as well as any obstacles or objects in the way, and the distance between the machine and the patient. All of these factors are important in ensuring the effectiveness and safety of the automatic CPR machine.

### 2.10.5 Bluetooth Module

Bluetooth Module HC-05 is a commonly used wireless communication module that can connect devices over short distances. It uses Bluetooth technology to transmit and receive data wirelessly [122]. In an automatic CPR machine, Bluetooth Module HC-05 can be used to control the device remotely, which is especially useful in emergency situations. With Bluetooth technology, healthcare providers can control the CPR machine from a safe distance, reducing the risk of contamination and exposure to infectious diseases. Bluetooth Module HC-05 can be easily integrated with the Arduino Uno, allowing for seamless communication and control [123].

The main advantage of using Bluetooth Module HC-05 in an automatic CPR machine is its wireless connectivity. This allows healthcare providers to control the device remotely, reducing the risk of exposure to infectious diseases. Bluetooth Module HC-05 is also easy to use and can be quickly integrated with the Arduino Uno. Additionally, the module is relatively inexpensive, making it a cost-effective solution for adding wireless communication to an automatic CPR machine [124].

One of the potential limitations of Bluetooth Module HC-05 is its limited range. The range of Bluetooth Module HC-05 is typically around 10 meters, which may be insufficient in some situations. However, there are other Bluetooth modules available with longer range, such as Bluetooth Module HC-12, which can provide a range of up to 1,000 meters [125]. Another limitation of Bluetooth Module HC-05 is its lower data transfer rate compared to other

wireless communication technologies such as Wi-Fi or cellular data. However, this may not be a significant concern for an automatic CPR machine, which does not require high-speed data transfer [126].

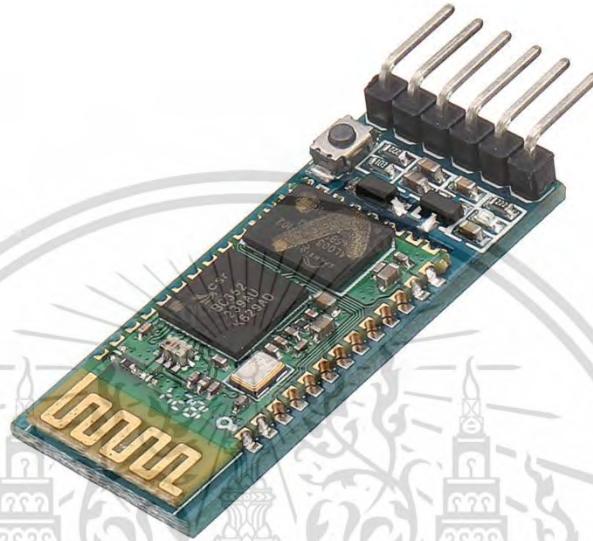

**Figure 2.10.5: Bluetooth Module HC-05 [127]**

Bluetooth Module HC-05 (*Figure 2.10.5*) is a cost-effective and easy-to-use wireless communication module that can be used in an automatic CPR machine to allow for remote control. While it may have limitations in terms of range and data transfer rate, it remains a practical solution for healthcare providers in emergency situations. The integration of Bluetooth Module HC-05 with the Arduino Uno and other components such as motor drivers and ultrasonic sensors can provide a comprehensive solution for building an effective automatic CPR machine.

### **2.10.6 Pushbutton**

Push buttons are simple electromechanical switches that are used to make or break an electrical connection. They are commonly used in many electronic devices and equipment for controlling various functions. In an

automatic CPR machine, a push button can be used to control the elevation of the CPR device.

When the push button is pressed, it activates a circuit that raises or lowers the CPR device to the desired height. This feature is useful when the patient's height or position needs to be adjusted during the CPR process. The push button can be mounted on the side of the device or on a remote control for easier access and convenience [128].

One important consideration when selecting a push button for an automatic CPR machine is its durability and reliability. The push button should be able to withstand frequent use and have a long lifespan to ensure that it remains functional during emergency situations. The button should also be designed to provide tactile feedback to the user, indicating that it has been pressed and the function has been activated [129].

Additionally, the push button should be designed with safety in mind. It should be easily accessible and clearly labeled to avoid confusion and prevent accidental activation. The button should also be designed to prevent unintentional activation, such as by requiring a firm press or by being recessed to avoid accidental contact [130].



**Figure 2.10.6: Red and Green momentary push button switch [131]**

A push button (**Figure 2.10.6**) can be a simple and effective way to control the elevation of an automatic CPR device. When selecting a push button, it is important to consider factors such as durability, reliability, tactile feedback,

and safety to ensure that it can withstand frequent use and remain functional during emergency situations.

### **2.10.7 Power source**

Power supply is an essential component of any electronic device, including the automatic CPR machine. It is responsible for converting the input voltage from the wall socket or battery into a regulated output voltage that can power the device's circuitry. In the case of the automatic CPR machine, the power supply must provide stable and reliable power to ensure the machine's proper operation [132].

One commonly used power supply for the automatic CPR machine is the AC-DC adapter. AC-DC adapters are external power supplies that convert AC voltage from the wall socket into DC voltage that the device can use. They are widely available, low cost, and provide a stable output voltage with low ripple and noise [133]. AC-DC adapters are also convenient for portable devices since they can be easily plugged into a wall socket or powered by a battery.

Another type of power supply that can be used in the automatic CPR machine is the battery. Batteries can be either rechargeable or disposable and can provide a stable output voltage. The advantage of using a battery as a power supply is that it provides portability and autonomy to the device, allowing it to function even in areas without access to a wall socket [134]. However, the disadvantage of using a battery is that it can add weight and bulk to the device and may require frequent recharging or replacement.

In addition to the power supply's type, the power supply's capacity must also be considered. The capacity of the power supply determines how long the device can operate on a single charge or how many compressions the machine can perform before requiring a recharge or replacement. Therefore, it is important to choose a power supply with a sufficient capacity to ensure the device's uninterrupted operation [135].

Finally, the power supply must also be designed to meet safety standards to prevent injury to the user and the patient. Safety standards such as IEC 60601-1 regulate the safety of medical electrical equipment by setting standards for

insulation, grounding, and leakage current. Compliance with these standards ensures that the device is safe for use in a clinical environment [136].



**Figure 2.10.7: Power supply [137]**

The power supply (*Figure 2.10.7*) is a critical component of the automatic CPR machine. The power supply must be reliable, stable, and safe to ensure the device's proper operation. Both AC-DC adapters and batteries can be used as power supplies, and the capacity of the power supply must be chosen carefully to ensure the device's uninterrupted operation. Compliance with safety standards such as IEC 60601-1 is also essential to ensure the device's safety in a clinical environment [138].

### 2.10.7.1 AC adapter

An AC adapter is an essential component for the operation of any electrical device that requires a constant power supply. The automatic CPR machine is no exception. The machine must be powered continuously for it to perform its life-saving function. AC adapters are widely used in the medical field, including the automatic CPR machine, due to their stability, reliability, and cost-effectiveness [139].

When selecting an AC adapter for an automatic CPR machine, it is crucial to consider the power requirements of the machine. The power supply

This material is reserved for educational use only, not allowed for commercial use.

Forbidden to modify the content, and cite the document when use.

must provide sufficient voltage and current to ensure that the machine functions optimally. The voltage and current requirements of the CPR machine will be specified by the manufacturer and can vary depending on the model of the machine. The AC adapter must be chosen carefully to ensure that it meets the specifications of the CPR machine [140].

In addition to meeting the power requirements, safety is also a critical factor when selecting an AC adapter for an automatic CPR machine. It is essential to select an adapter that complies with safety standards, such as UL or CE. This ensures that the adapter has been tested and certified for safety, including protection from electrical shock, fire, and other hazards. Furthermore, the AC adapter should have a built-in surge protector to protect the automatic CPR machine from power surges that could damage the device [141].

When it comes to the physical aspects of the AC adapter, it should be compact and easy to transport, especially for emergency situations where the automatic CPR machine needs to be moved quickly. The adapter should have a long cord to enable flexibility in placing the automatic CPR machine in different locations. Additionally, the adapter should have a low noise profile to prevent any unwanted interference with the machine's sensors [142].



**Figure 2.10.7.1: AC adapter [143]**

The AC adapter (**Figure 2.10.7.1**) is a crucial component of the automatic CPR machine. It provides the necessary power to operate the device

and must be chosen carefully to meet the power requirements and safety standards. The AC adapter should be compact, easy to transport, and have a long cord to provide flexibility in placement. Finally, the adapter should have a low noise profile to prevent any unwanted interference with the machine's sensors.

### 2.10.8 Force sensor

Force sensors (*Figure 2.10.8*) are essential components of an automatic cardiopulmonary resuscitation (CPR) machine. These sensors are used to measure the force or pressure applied during the chest compression phase of CPR, and they provide valuable feedback on the effectiveness of the compressions being delivered. Force sensors are an important part of the CPR machine as they help ensure that the compressions are delivered correctly and with the appropriate amount of force.

There are several different types of force sensors that can be used in a CPR machine, including load cells, piezoelectric sensors, and strain gauges. Load cells are among the most common type of force sensor used in CPR machines. These sensors use a deformation of a metallic material to measure the amount of force being applied, which is then converted into an electrical signal that can be used for feedback. Piezoelectric sensors, on the other hand, use a crystal that generates an electrical signal when it is subjected to pressure or force. Strain gauges measure the amount of deformation of a metallic strip when a force is applied and can be used to determine the amount of force being applied during chest compressions [144].

The use of force sensors in automatic CPR machines is becoming increasingly common due to their ability to provide accurate and reliable feedback on the quality of chest compressions being delivered. By measuring the force and pressure applied during the compression phase, force sensors can help ensure that the compressions are delivered with the correct technique and the appropriate amount of force. This can improve the outcomes for patients

who require CPR, particularly in situations where traditional manual CPR is difficult or ineffective [145].

In addition to providing feedback on the force and pressure applied during chest compressions, force sensors can also help detect when the patient's condition changes. For example, if the patient's chest becomes more rigid or if their breathing rate increases, the force sensors can detect these changes and adjust the force and timing of the compressions accordingly. This can help ensure that the patient receives optimal care and can increase the chances of a successful outcome [146].

Overall, force sensors are an important part of any automatic CPR machine. By providing accurate and reliable feedback on the force and pressure applied during chest compressions, these sensors can help improve the quality of care provided to patients who require CPR. As the use of automatic CPR machines becomes more common, the development and use of more advanced and sophisticated force sensors is likely to continue to grow [147].



**Figure 2.10.8: Force sensitive resistor [148]**

### 2.10.9 ECG Module

ECG (electrocardiogram) is a widely used non-invasive medical technique that records the electrical activity of the heart. In an automatic CPR system, the ECG module can be used to monitor the heart rhythm and provide real-time feedback to the automated compression system. The ECG module typically consists of electrodes, amplifiers, filters, and an analog-to-digital converter [149].

One important consideration when selecting an ECG module for an automatic CPR machine is the quality of the signal. The ECG signal is susceptible to various types of noise, including electrical interference from other medical devices and movement artifacts from patient motion. To ensure accurate and reliable measurements, the ECG module should be designed with a high signal-to-noise ratio and incorporate signal processing techniques such as filtering and artifact rejection [150].

Another important factor to consider when choosing an ECG module is the cost. While there are many high-end ECG modules available on the market, they may not be practical for use in an automatic CPR machine due to their high cost. It is important to balance the cost of the ECG module with the performance requirements of the system to ensure that the overall cost of the automatic CPR machine remains reasonable [151].

The size and weight of the ECG module are also important factors to consider, especially if the automatic CPR machine is intended for use in a mobile setting. Portable ECG modules (*Figure 2.10.9*) are available that are lightweight and compact, making them well-suited for use in an automatic CPR machine that may need to be transported from one location to another [152].

Finally, it is important to consider the ease of integration of the ECG module with the other components of the automatic CPR machine. Ideally, the ECG module should have a standardized interface and protocol that allows for easy integration with the motor control, compression depth sensors, and other components of the system. This can help to reduce the overall complexity of the system and make it easier to maintain and troubleshoot [153].

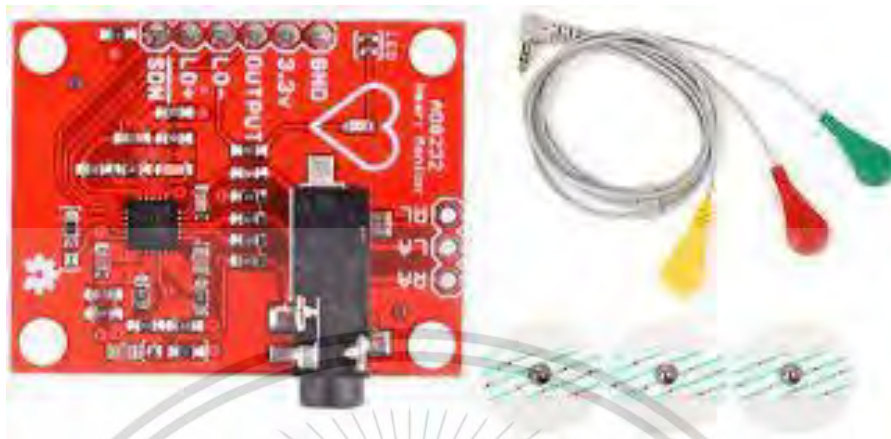

*Figure 2.10.9: ECG module [154]*

ECG synchronization with CPR is essential for several reasons. Firstly, it allows for the precise timing of chest compressions in relation to the electrical activity of the heart. By synchronizing compressions with the R wave of the ECG signal, we ensure that the heart is in the optimal phase of its cardiac cycle for effective circulation. This synchronization helps to maximize blood flow to vital organs, including the brain and the heart itself.

Secondly, ECG synchronization helps to avoid compressions during the vulnerable period of cardiac repolarization, known as the T wave. Compressions delivered during this phase can lead to ventricular fibrillation, a potentially life-threatening rhythm disturbance. By coordinating compressions with the R wave, we minimize the risk of triggering or exacerbating harmful cardiac rhythms.

Furthermore, ECG synchronization provides feedback on the effectiveness of CPR. By monitoring the ECG waveform during compressions, we can assess the quality and consistency of chest compressions. Deviations in the ECG waveform can indicate the need for adjustments in compression depth, rate, or technique to optimize the delivery of CPR.

### 2.10.9.1 Abnormal electrocardiogram

Abnormal electrocardiogram (ECG) readings often include the presence of atrial fibrillation (AF). Atrial fibrillation is a common cardiac arrhythmia characterized by irregular and rapid electrical impulses in the atria of the heart. During AF, the normal coordinated contraction of the atria is disrupted, leading to an irregular heartbeat. Instead of the normal sinus rhythm, the ECG waveform in AF shows chaotic and disorganized electrical activity in the atria. This irregularity is represented by the absence of distinct P waves and the presence of rapid, irregular, and irregularly spaced QRS complexes on the ECG. The irregular ventricular response seen in AF can also lead to an irregular pulse. Atrial fibrillation can be intermittent or sustained and may be associated with symptoms such as palpitations, shortness of breath, chest discomfort, and fatigue. It is important to promptly diagnose and manage AF to prevent complications such as stroke, heart failure, and other cardiovascular events [155].

Atrial fibrillation (AF) is a cardiac arrhythmia characterized by an abnormal heart rhythm originating in the atria, the upper chambers of the heart. In atrial fibrillation, the electrical signals that coordinate the contraction of the atria become chaotic, causing them to quiver or fibrillate instead of contracting normally. This results in an irregular and often rapid heartbeat. Atrial fibrillation can occur sporadically or persistently and may be asymptomatic or accompanied by a range of symptoms, including palpitations, fatigue, shortness of breath, dizziness, and chest discomfort. It is a common condition, with various underlying causes, including age, high blood pressure, heart disease, and certain medical conditions. Proper diagnosis and management are important to control symptoms, prevent complications, and reduce the risk of stroke or other cardiovascular events associated with atrial fibrillation [156].

## 2.11 Chapter Summary

Chapter 1 serves as an introduction to the project, outlining the need for automating the cardiopulmonary resuscitation (CPR) machine and presenting the project's objective. It emphasizes the significance of CPR as a life-saving technique in emergency situations and highlights the importance of automating the process to enhance its effectiveness and efficiency.

Chapter 2 delves into a comprehensive exploration of CPR, starting with a detailed explanation of the difference between cardiac arrest and cardiac attack in section 2.4. It further elaborates on the method of performing CPR, covering the essential steps and techniques involved in section 2.5 and section 2.6, respectively. The chapter also includes a discussion on the various approaches to performing CPR on adults and children, emphasizing the differences and considerations in section 2.7.

To provide a broader context, section 2.2 delves into the history of CPR, tracing its origins and evolution over time. In section 2.8, existing CPR devices are examined, evaluating their features, functionalities, and limitations to identify areas for improvement. The effectiveness of automatic CPR devices is explored in section 2.9, highlighting the advantages and potential impact of automation in improving patient outcomes. Finally, section 2.10 focuses on the materials used in constructing automatic CPR devices, emphasizing the importance of selecting durable and reliable components.

Moving forward, the subsequent chapter (Chapter 3) delves into the design aspect of the automatic cardiopulmonary resuscitation system. It presents the system's overall design, including detailed diagrams and illustrations of its components and their interconnections. Furthermore, the chapter provides insights into the assembly process of the machine, documenting the steps taken and discussing any challenges encountered. By the end of the chapter, readers gain a comprehensive understanding of the design and physical realization of the automatic CPR system.

## **CHAPTER 3**

### **SYSTEM INSTALLATION AND DESIGN**

#### **3.1 Introduction**

In this chapter, the focus shifts towards the implementation and design aspects of the automatic cardiopulmonary resuscitation (CPR) machine. Building upon the foundation established in the previous chapters, Chapter 3 delves into the practical considerations and technical details involved in bringing the automatic CPR machine to life.

The chapter begins with an introduction to the installation process, emphasizing the importance of proper setup and configuration for optimal performance. Key considerations and requirements are discussed to ensure that the automatic CPR machine operates seamlessly within the intended environment.

Following the installation overview, the chapter delves into the design principles and guidelines employed during the development of the automatic CPR machine. Ergonomic design, user-friendly interfaces, and integration of essential features are highlighted as key factors in enhancing the effectiveness and usability of the system. The chapter delves into the design process, showcasing the thought and careful planning that went into creating an efficient and intuitive machine.

One of the core components discussed in Chapter 3 is the circuit diagram. This visual representation provides a comprehensive overview of the electrical connections and components utilized in the automatic CPR machine. The circuit diagram serves as a crucial reference point, aiding in understanding the intricate electrical infrastructure and ensuring proper functioning of the system.

In addition to the hardware aspects, the chapter explores the design of the mobile app interface used to control and monitor the automatic CPR machine. User-friendly and intuitive design principles are employed to enhance the user experience and facilitate seamless operation of the system. The chapter

examines the key features, functionalities, and visual elements of the mobile app interface, showcasing its role in empowering users to interact with the CPR machine effectively.

The chapter delves into the hardware assembly process, providing a step-by-step account of how the various components of the automatic CPR machine are integrated. Attention is given to ensuring proper alignment, secure connections, and reliable functionality, while also addressing any challenges encountered during the assembly process.

### 3.2 Material and method

An automatic resuscitation system is a life-saving medical device that can provide continuous cardiac and pulmonary support to a patient in cardiac arrest. The system typically consists of three key components: an automatic CPR machine, an emergency ventilator, and an ECG module. The automatic CPR machine provides consistent and effective chest compressions, while the emergency ventilator helps maintain oxygenation of the patient's blood. The ECG module monitors the patient's heart rhythm and provides critical information about the patient's cardiac activity.

The automatic CPR machine is the core component of the automatic resuscitation system. It provides consistent and effective chest compressions to the patient, helping to maintain blood flow to the vital organs. The machine typically uses a linear actuator or a piston-driven system to compress the chest and is controlled by an Arduino Uno microcontroller with motor driver shields such as L298N or MD10 R2. The use of force sensors can help ensure that the compressions are consistent and provide adequate depth. The machine may also be equipped with a push button to control the elevation of the CPR device. Overall, the automatic CPR machine provides critical support to the patient in cardiac arrest and helps maximize the chances of a successful resuscitation.

The use of an ECG module can also help ensure that the patient's oxygenation needs are met, by providing critical information about the patient's cardiac activity. ECG-synchronized CPR is a technique that combines the use of electrocardiogram (ECG) monitoring with cardiopulmonary resuscitation (CPR) to enhance the

This material is reserved for educational use only, not allowed for commercial use.

effectiveness of resuscitation efforts. In this approach, the ECG signal is continuously monitored, specifically focusing on the R wave, which represents the electrical depolarization of the heart's ventricles. The CPR compressions are then synchronized with the R wave, ensuring that chest compressions are performed during the cardiac refractory period, when the heart is most receptive to circulation. This synchronization optimizes the timing of compressions, increasing the likelihood of effective blood flow and oxygenation. By aligning CPR with the patient's underlying cardiac rhythm, ECG-synchronized CPR improves the chances of successful resuscitation and can potentially lead to better outcomes for individuals experiencing cardiac arrest.

The ECG module is the third component of the automatic resuscitation system. It provides critical information about the patient's cardiac activity, including heart rate, rhythm, and electrical activity. The ECG module may be integrated into the automatic CPR machine, or maybe a separate component connected to the system. The module typically uses leads placed on the patient's chest to detect and analyze the patient's cardiac activity. This information can help guide the resuscitation efforts, by identifying the need for defibrillation or medication, for example.

The design of the automatic resuscitation system is critical to its effectiveness in saving lives. The integration of the automatic CPR machine, emergency ventilator, and ECG module provides a comprehensive and coordinated approach to resuscitation. The use of force sensors, motor driver shields, and push buttons can help ensure that the compressions provided by the automatic CPR machine are consistent and effective. The use of a portable emergency ventilator can provide reliable and consistent oxygenation to the patient. The use of an ECG module can help guide the resuscitation efforts by providing critical information about the patient's cardiac activity.

The automatic resuscitation system is a critical life-saving device that can provide continuous cardiac and pulmonary support to a patient in cardiac arrest. The system consists of three key components: an automatic CPR machine, an emergency ventilator, and an ECG module. The integration of these components provides a comprehensive and coordinated approach to resuscitation, maximizing the chances of a successful outcome. The design of the system is critical to its effectiveness, and the use of force sensors, motor driver shields, push buttons, and portable emergency ventilators can help ensure that the system functions effectively in saving lives.

This material is reserved for educational use only, not allowed for commercial use.

Forbidden to modify the content, and cite the document when use.

### 3.3 Design of automatic cardiopulmonary resuscitation device

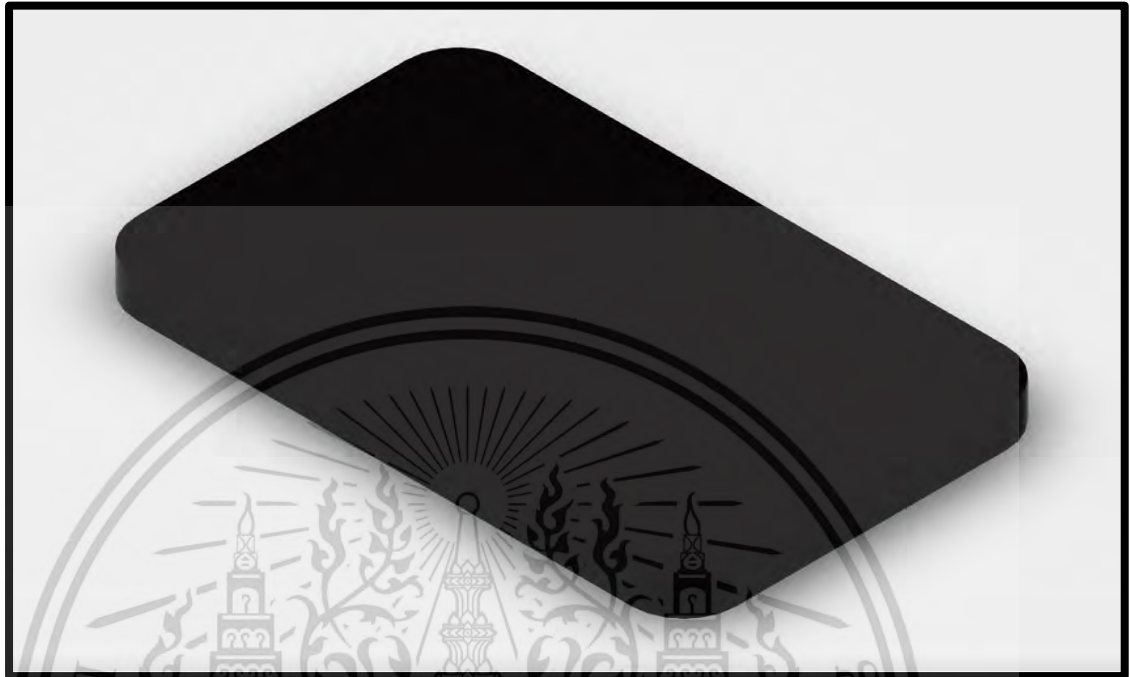

*Figure 3.3.1: Design of the base of automatic CPR device*

The design for the base of the CPR machine is an important aspect in ensuring the stability and durability of the device. The base should be able to support the weight of the device and the person being resuscitated, while also maintaining a steady and balanced platform. The material used for the base should be sturdy and able to withstand regular use and potentially harsh conditions. Additionally, the design should allow for easy maneuverability and transportability if necessary. In *Figure 3.3.1* is the design of the base of the automatic CPR device. This is the part that will support the CPR device that will contain all the components of the automatic cardiopulmonary resuscitation. The base of the automatic cardiopulmonary resuscitation device has a width of 200 mm and length of 400 mm and a height of 10 mm. Regardless of the specific design, it is important to consider the weight of the base in relation to the overall weight of the device. The base should be heavy enough to provide stability, but not so heavy that it impedes mobility. The base should also be designed with easy cleaning in mind to ensure proper hygiene and reduce the risk of infection.

The design of the base for the CPR machine is an important aspect to consider when creating a reliable and effective resuscitation system. A sturdy and

This material is reserved for educational use only, not allowed for commercial use.

Forbidden to modify the content, and cite the document when use.

stable platform is necessary to ensure the safety of the person being resuscitated, while also allowing for easy maneuverability and transportability. With careful consideration and design, the base can provide the necessary foundation for a successful CPR machine.

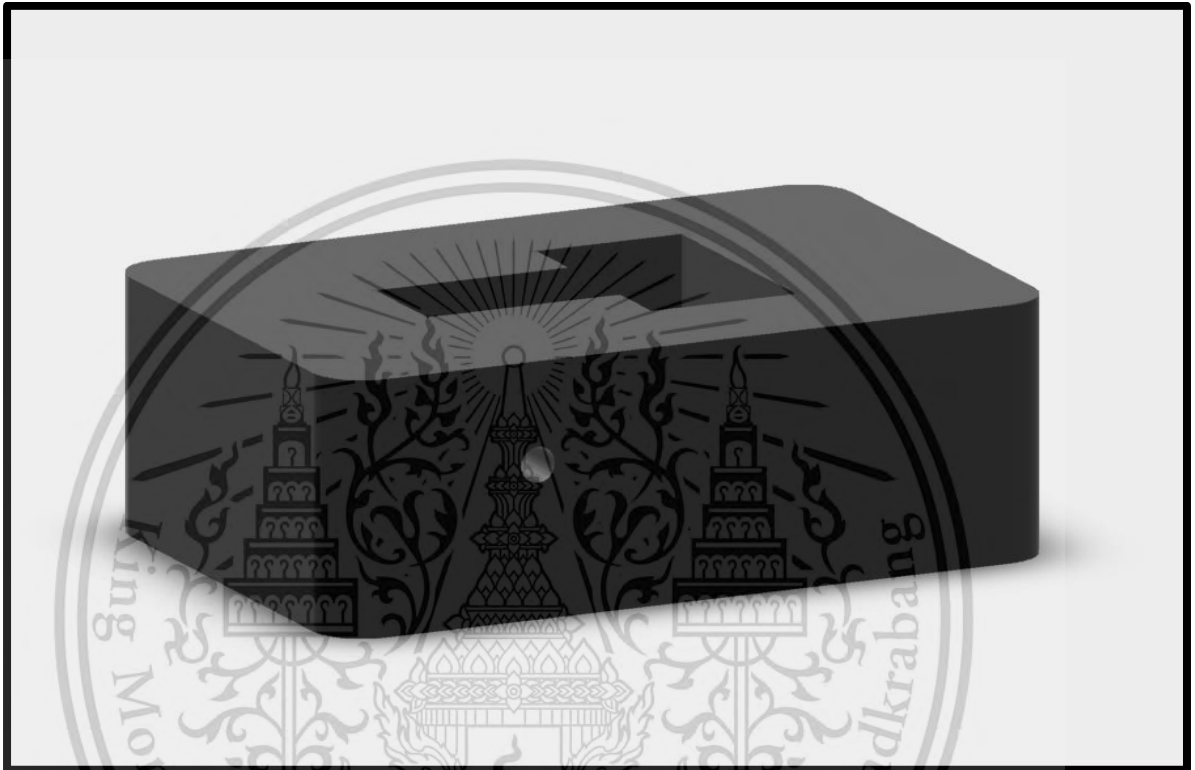

***Figure 3.3.2: Design of the motor holder of automatic CPR device***

The design of the motor holder is an essential aspect of the automatic CPR device. It is responsible for holding the motor and ensuring that it is securely attached to the base of the machine. The motor holder should be designed to fit the specific motor being used, and it must provide a stable platform for the motor to operate. Additionally, the motor holder should be designed to allow for easy access to the motor and any necessary adjustments or maintenance. Overall, a well-designed motor holder is crucial for the smooth and efficient operation of the automatic CPR machine. In ***Figure 3.3.2*** is the design of the motor holder of the automatic CPR device. This is the part designed to contain the motor and all of the microcontroller devices. The size of the motor holder should allow the motor to be in the correct hand position and the motor holder should be strong enough to withstand the force of the

This material is reserved for educational use only, not allowed for commercial use.

Forbidden to modify the content, and cite the document when use.

motor. The motor holder of the automatic cardiopulmonary resuscitation device has a width of 200 mm and length of 300 mm and a height of 100 mm.



**Figure 3.3.3: Design of the rubber of automatic CPR device**

The rubber surface (*Figure 3.3.3*) on the compression component of the cardiopulmonary resuscitation equipment is a critical design element that requires careful consideration. One of the primary concerns is ensuring that the rubber surface is large enough to provide adequate coverage while also preventing excessive stress on the patient. If the rubber surface is too small, it could lead to the concentration of force on a smaller area, increasing the likelihood of rib fractures and other injuries. Therefore, a diameter of 100 mm has been selected as an appropriate size to ensure that the rubber surface provides sufficient coverage while minimizing the risk of injury.

Another critical aspect of the design of the rubber surface is its material composition. The material should be durable enough to withstand repeated use without significant wear and tear, yet soft enough to provide adequate

This material is reserved for educational use only, not allowed for commercial use.

Forbidden to modify the content, and cite the document when use.

cushioning for the patient. A common material used in the design of these rubber surfaces is silicone, which has been shown to have excellent durability and elasticity while providing the necessary cushioning for the patient.

In addition to the size and material of the rubber surface, other design considerations include the method of attachment to the compression component and ease of replacement. The rubber surface should be securely attached to the compression component to prevent any shifting during use, while also allowing for easy replacement when necessary.

Overall, the design of the rubber surface for the compression component of the automatic CPR device is a critical element that requires careful consideration to ensure both patient safety and equipment functionality. By selecting an appropriate size and material, as well as a secure attachment method and ease of replacement, the rubber surface can provide the necessary coverage and cushioning for effective CPR without compromising patient safety.

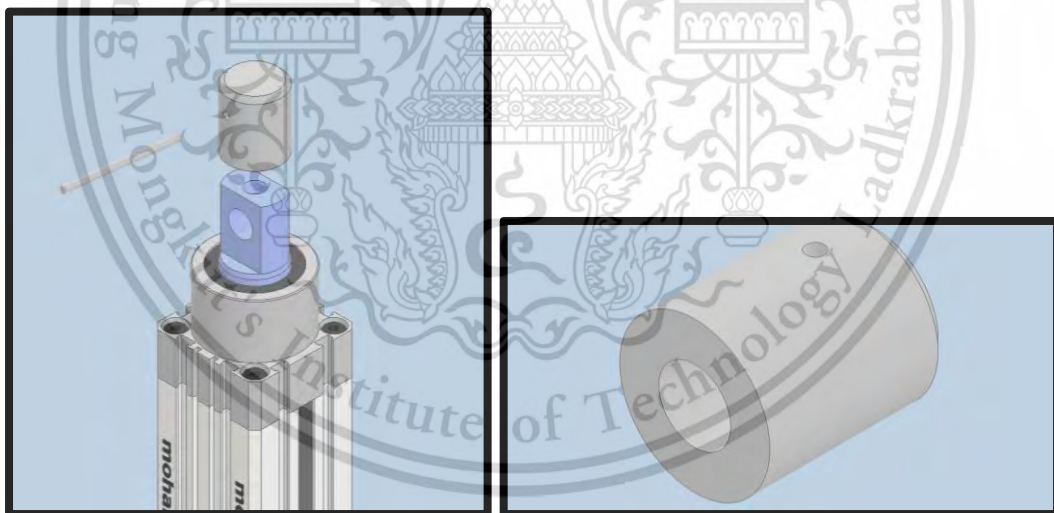

*Figure 3.3.4: Linear actuator connector*

A short steel rod is shown in **Figure 3.3.4** that was cut from the original portion. Drill a hole around 20 millimeters in diameter and a depth of 1 inch to connect it to the linear actuator, then fasten it with a steel rod from the old portion. The second linear actuator will be connected to the motor holder with this part.

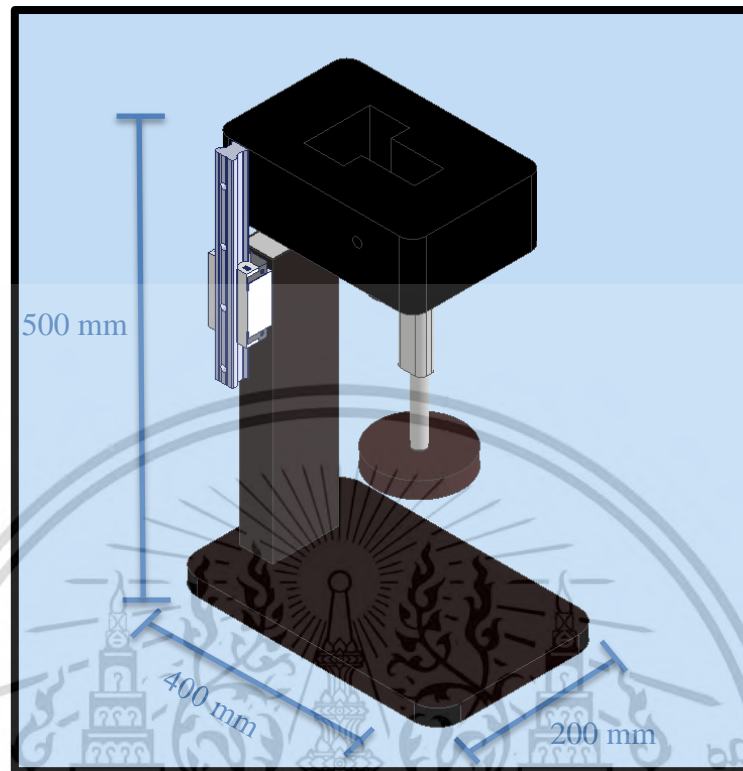

**Figure 3.3.5: Assembly design of the automatic CPR device**

The assembly of the automatic CPR machine is designed with dimensions of 200mm in width, 500mm in height, and 400mm in length (**Figure 3.3.5**). The base height of the device is set at 500mm, but it has the capability to extend its height using a linear actuator, reaching a maximum height of 650mm. This adjustable feature allows the device to accommodate different patient sizes and optimize the compression process for effective cardiopulmonary resuscitation.

The assembly of the automatic CPR machine involves several key components, including the base, compression component, motor holder, motor driver shield, motor driver L298N, ultrasonic sensor, Bluetooth module, push button, power supply, ECG module, and emergency ventilator. The base of the machine is designed to provide a stable foundation, while the compression component is responsible for applying pressure to the patient's chest. The motor holder is designed to securely hold the motor and allow for easy access and maintenance. The motor driver shield and L298N are essential for controlling the motor, while the ultrasonic sensor is used for detecting the patient's chest

This material is reserved for educational use only, not allowed for commercial use.

Forbidden to modify the content, and cite the document when use.

movement. The Bluetooth module and push button are used for controlling the machine, while the power supply provides the necessary power. The ECG module is used for monitoring the patient's heart rate, and the emergency ventilator is used in conjunction with the automatic CPR machine to provide complete resuscitation. The design assembly of the automatic CPR machine must take into account all of these components to ensure that the machine functions properly and efficiently.

As for the adjustment for the compression distance part to be more precise, I first tried using a linear rail and a stepper motor with a helix, however, the linear rail could not be placed to hold the linear actuator holder in position. And because the linear actuator holder is quite heavy the linear rail is too narrow to sustain the weight of the linear actuator holder. In the design (shown in *Figure 3.3.5*), I switch from utilizing the linear rail to control compression distance precision to using the second linear actuator that will be controlled by buttons. The first linear actuator, which will compress the patient, will be controlled by a mobile phone using App Inventor, while the second linear actuator, which will regulate the device's up and down movement, will be controlled by push button switches.

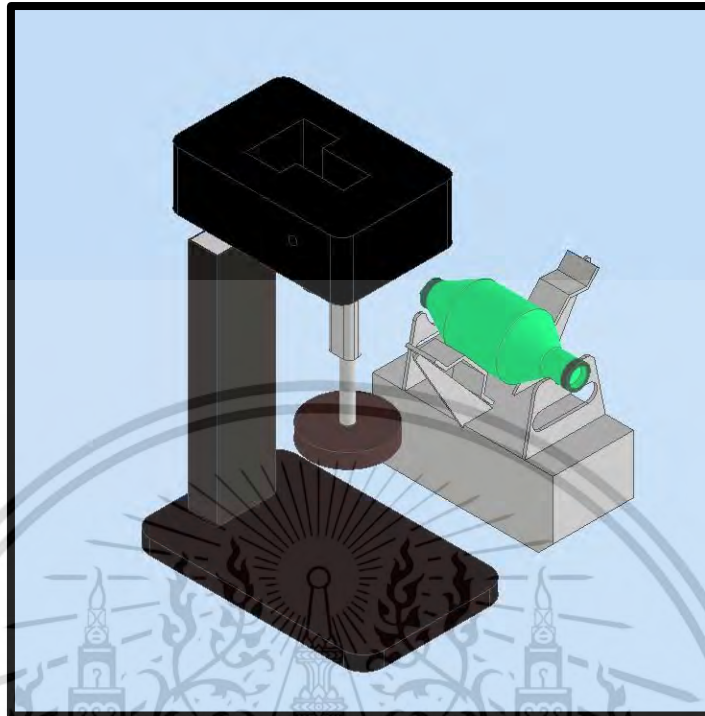

**Figure 3.3.6: The assembly of the automatic resuscitation system**

The assembly of the automatic resuscitation system (*Figure 3.3.6*) involves the integration of three main components: the automatic CPR machine, and the ECG module. The assembly of these components is critical to ensure the effective functioning of the system.

The automatic CPR machine consists of a motor, motor driver shield MD10 R2, motor driver L298N, push buttons, ultrasonic sensors, Bluetooth module HC-05, force sensors, power supply, and the base. The motor driver shields are mounted on the base to control the motor and allow the machine to perform chest compressions on the patient. The push buttons are attached to the base and are used to control the elevation of the machine. Ultrasonic sensors are mounted on the machine to detect the distance between the patient and the machine. The Bluetooth module HC-05 allows the machine to connect to a remote device, such as a mobile phone, for monitoring purposes. Force sensors are placed on the compression component of the machine to ensure that the correct amount of force is applied to the patient during chest compressions. A power supply is used to provide the necessary electrical energy to run the machine.

The ECG module is used to monitor the heart rate and rhythm of the patient. It includes electrodes that are placed on the chest of the patient to measure the electrical activity of the heart. The emergency ventilator is also controlled by the microcontroller and delivers oxygen to the patient based on their respiratory rate and oxygen saturation levels. The force sensors on the compression component of the machine ensure that the correct amount of force is applied to the patient during chest compressions. The Bluetooth module allows for remote monitoring and control of the system. The design of an ECG-synchronized CPR system involves the integration of ECG monitoring technology with a CPR device to optimize the timing and effectiveness of chest compressions. The system utilizes the ECG signal to detect the R wave, which represents the electrical activity associated with ventricular contraction. By synchronizing the CPR device with the R wave, chest compressions can be delivered at the optimal time during the cardiac cycle, maximizing blood flow and perfusion to vital organs.

The assembly of the automatic resuscitation system requires careful consideration and integration of multiple components. The automatic CPR machine, emergency ventilator, and ECG module are all critical to the effective functioning of the system. Proper calibration and connection of the components are essential for the successful operation of the system, and any errors or malfunctions must be identified and addressed promptly. The automatic resuscitation system represents a significant advancement in the field of emergency medicine and has the potential to save countless lives in critical situations.

### 3.4 App Inventor

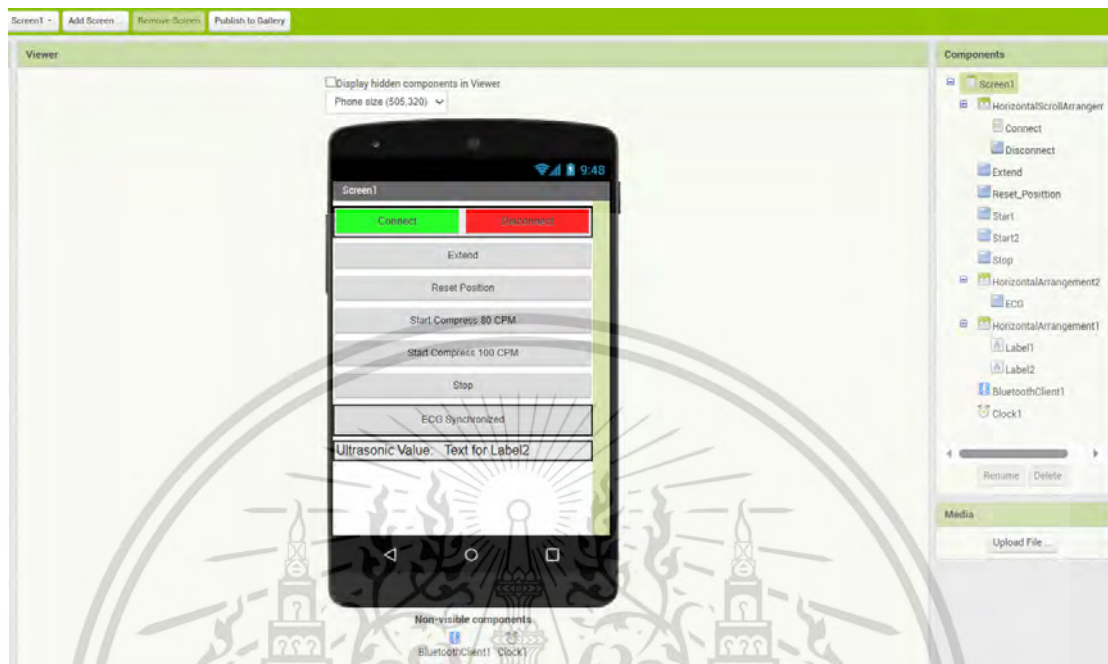

**Figure 3.4: App Inventor interface design**

**Figure 3.4** shows the primary components and functionalities of the interface.

**List Picker for Bluetooth Device Connection:** The app interface incorporates a list picker that allows users to select the specific Bluetooth device to establish a connection. This feature offers flexibility, enabling users to connect to different devices based on their preferences or specific requirements.

**Disconnect Button:** To provide users with control over the Bluetooth connection, the interface includes a disconnect button. This button allows users to effortlessly terminate the Bluetooth connection, facilitating smooth disconnection and enhancing the overall usability of the app.

**Extend Button:** The interface integrates an extended button, which triggers the linear actuator motor to extend to its maximum length. This functionality ensures proper positioning and preparation of the CPR device, optimizing compression performance during resuscitation procedures.

**Return Position Button:** For the linear actuator motor to return to its minimum length, a return position button is included in the app interface. This

feature enables users to easily reset the linear motor, ensuring efficient device management and preparation for subsequent use.

**Compression Rate Buttons:** Recognizing the significance of consistent and appropriate chest compressions during CPR, the app interface provides users with dedicated buttons to control the compression rate. By selecting the desired rate, such as 80 or 100 compressions per minute, users can adhere to recommended standards for effective resuscitation.

**Stop Button:** To address situations that require the immediate cessation of the linear motor's operation, the app interface includes a stop button. Users can quickly halt the motor's movement, enhancing safety and enabling swift response to unforeseen circumstances during CPR procedures.

**Ultrasonic Value Changing Label:** The app interface incorporates an ultrasonic value changing label that displays real-time data from an ultrasonic sensor. This feature provides users with valuable information about the distance or position relevant to the CPR device, allowing for precise adjustments and ensuring accurate positioning during chest compressions.

**Clock:** To enhance usability and keep users informed, the app interface includes a clock feature. This clock displays the current time, enabling users to track the duration of CPR procedures or time intervals between compressions.

**ECG Synchronized button:** When pressing this button, the CPR machine will switch to ECG synchronized mode. In this mode, the compression of the CPR machine is synchronized to the ECG signal R wave.

The development of an app interface using App Inventor for controlling an automatic CPR device represents a significant advancement in the field of medical technology. The integration of features such as the list picker for Bluetooth device connection, disconnect button, extend and return position buttons for linear actuator control, compression rate buttons, and a stop button enables users to control the CPR device efficiently.

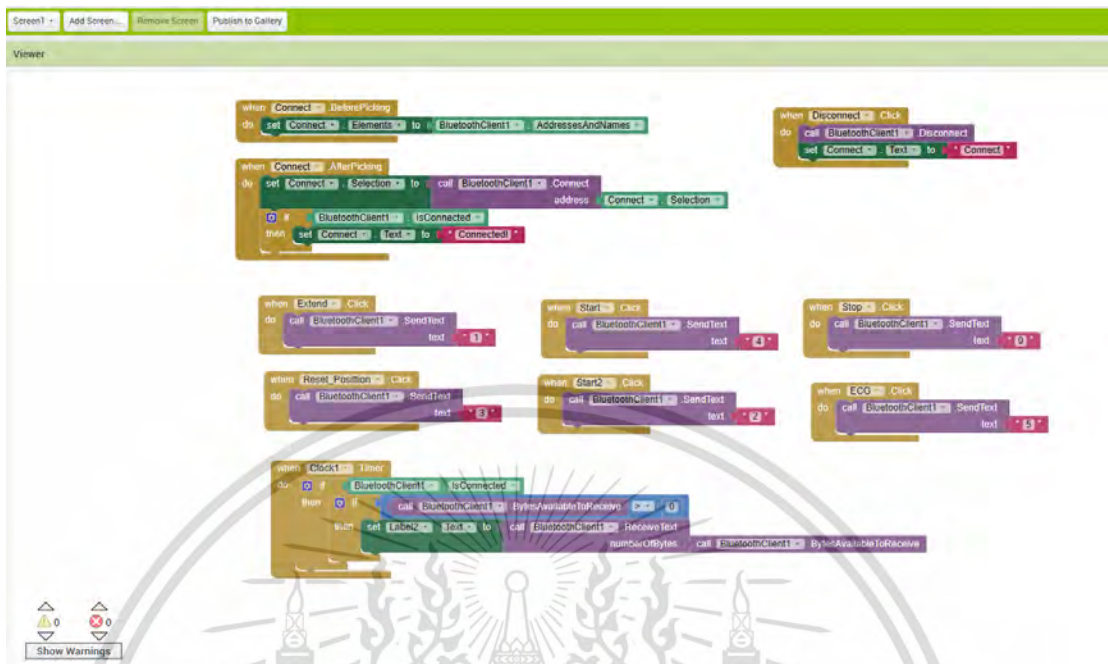

**Figure 3.4.1: App Inventor block diagram**

The App Inventor block interface plays a crucial role in control of the automatic CPR device shown in *Figure 3.4.1*.

**Connect List Picker:** The Connect List Picker component allows users to select the specific Bluetooth device they wish to connect to. This feature offers flexibility and convenience, allowing users to establish a connection with their preferred device for controlling the CPR system.

**Bluetooth Connection:** The Bluetooth Connection component establishes a seamless connection between the app and the Arduino, enabling wireless communication. This connection is vital for transmitting commands and receiving data to control the automatic CPR device.

**Disconnect Button:** The Disconnect Button component allows users to terminate the Bluetooth connection effortlessly. By clicking this button, users can disconnect from the connected Bluetooth device, providing a streamlined user experience and ensuring smooth disconnection.

**Return Position Button:** When the Return Position Button is clicked, the corresponding block sends the value '3' to the Arduino. This command instructs the Arduino to stop the linear actuator motor and return it to its original position.

This functionality ensures proper resetting of the CPR device for subsequent use.

**Extend Button:** When the Extend Button is clicked, the corresponding block sends the value '1' to the Arduino. This command triggers the linear actuator motor to extend to its maximum length, allowing optimal positioning and preparation of the CPR device for effective chest compressions.

**80 and 100 Compression Buttons:** The 80 Compression Button and 100 Compression Button components provide users with the ability to initiate CPR chest compressions at specific rates. When either button is clicked, the corresponding block sends the values '2' or '4' to the Arduino, respectively. These commands enable Arduino to control the compression rate of the CPR device accordingly.

**Stop Button:** Clicking the Stop Button sends the value '0' to the Arduino. This command immediately halts the operation of the linear actuator motor, ensuring prompt response to any emergency situation during CPR procedures.

**ECG synchronize Button:** By pressing the ECG Button sends the value '5' to the Arduino. This will make the linear actuator compress according to the ECG signal R wave. Making the compression synchronize with the ECG signal.

The block diagram of the App Inventor interface serves as a critical control mechanism for the automatic CPR device. It consists of components such as the Connect List Picker, Bluetooth Connection, Disconnect Button, Return Position Button, Extend Button, 80 and 100 Compression Buttons, and Stop Button. These components work together to establish Bluetooth connections, transmit commands, and control the linear actuator motor for proper chest compressions during CPR procedures.

Controlling the automatic resuscitation system through a phone or mobile application offers several benefits. First, it provides convenience and ease of use for the user, who can control and monitor the system from a distance or while attending to other tasks. Second, it allows for wireless communication between the device and the user's phone, eliminating the need for cumbersome wires or cables. Third, using a phone as a control interface allows for a more user-friendly and intuitive design, as many people are already familiar with

using apps on their phones. Finally, it enables real-time monitoring and data collection, which can be useful for medical professionals or researchers.

### 3.5 Circuit diagrams

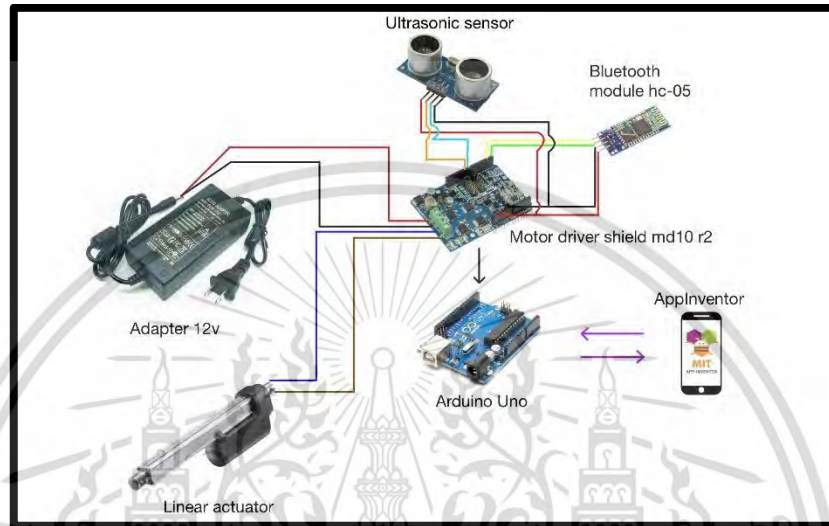

**Figure 3.5: Circuit diagram for compression linear actuator**

The automatic CPR device shown in **Figure 3.5** is designed to provide effective chest compressions to patients in need of cardiopulmonary resuscitation. The linear actuator motor, which is powered by 12 volts, is the main component responsible for performing the chest compressions. The motor is connected to the motor driver shield, which allows for precise control of the motor's movements. The Arduino, which serves as the device's brain, is also connected to the motor driver shield, as well as the ultrasonic sensor and Bluetooth module.

The ultrasonic sensor, which is connected to Arduino pins 8 and 9, is used to detect the distance between the device and the patient's chest. This information is then used to adjust the depth of the chest compressions to ensure that they are effective without causing harm to the patient. The Bluetooth module, which is connected to Arduino pins TX and RX, allows for wireless communication between the device and the app inventor's interface.

By using a Bluetooth connection, the app inventor can control the device wirelessly, making it easier to use and more convenient for healthcare providers.

The app inventor can adjust the compression rate of the device, with options for

This material is reserved for educational use only, not allowed for commercial use.

Forbidden to modify the content, and cite the document when use.

100 and 120 compressions per minute. The app inventor can also reset the linear actuator motor to its starting position and receive real-time data from the ultrasonic sensor.

Overall, the design of the automatic CPR device is carefully crafted to ensure the safe and effective delivery of chest compressions to patients in need of resuscitation. The combination of the linear actuator motor, motor driver shield, Arduino, ultrasonic sensor, and Bluetooth module creates a sophisticated system that can be controlled wirelessly with ease.

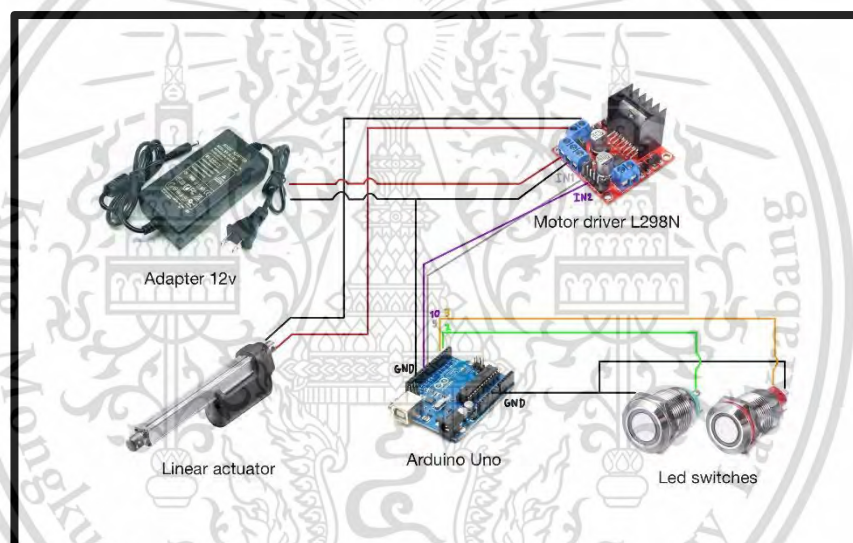

**Figure 3.5.1: Circuit diagram for the second linear actuator**

In the circuit diagram shown in *Figure 3.5.1*, the L298N motor driver will be connected to a 12V power supply or adapter, which will provide power to the motor. The linear actuator will be connected to the motor driver, and the motor driver will be controlled by Arduino pins 10 and 9, which will be used as outputs and connected to IN1 and IN2 on the motor driver. The Arduino's pins 2 and 3 will power the led switches, which will be used to control the linear actuator. When the button attached to pin 2 is pressed, the linear actuator will extend, and when the button attached to pin 3 is pressed, the linear actuator will retract. This will allow for precise control of the linear actuator without the need for wireless communication or the use of the app inventor. The use of led switches also provides visual feedback to the user, indicating the direction in

which the linear actuator is moving. Overall, the circuit diagram for the second linear actuator provides a simple and effective way to control the device without the need for a mobile device or wireless communication.

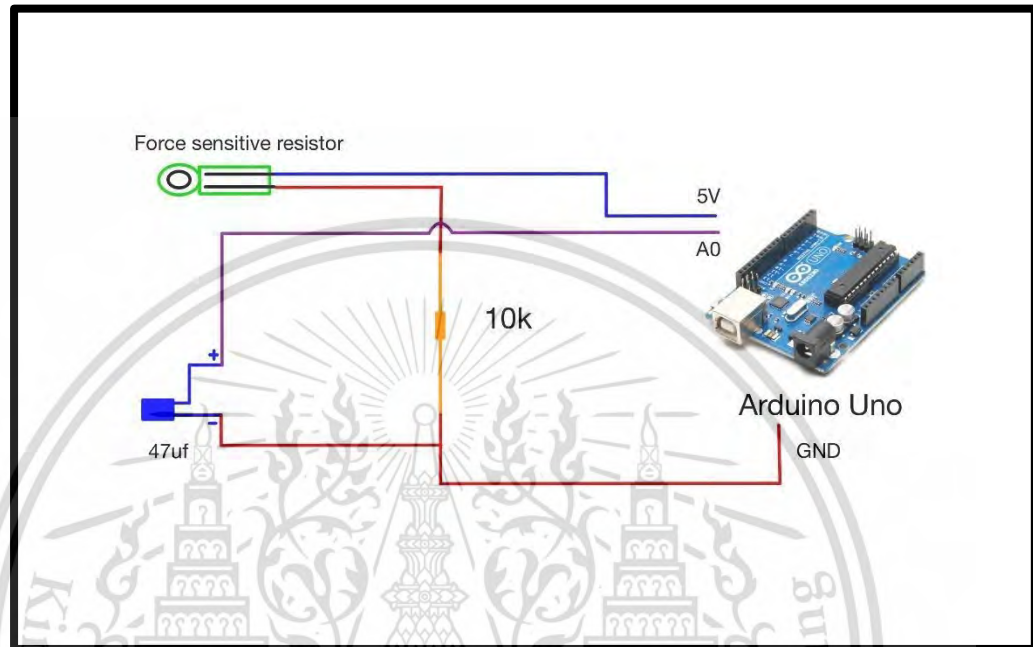

**Figure 3.5.2: Circuit diagram for force sensors**

The circuit diagram for the FSR (*Figure 3.5.2*) connected to an Arduino Uno using a 10k ohm resistor is a basic setup that allows the Arduino to read the changes in resistance from the FSR. The FSR is a sensor that changes its resistance when a force is applied to it. The 10k ohm resistor is used as a pull-down resistor, which helps to stabilize the voltage and reduce any noise or fluctuations in the circuit.

The circuit diagram consists of four main components: the FSR, the 10k ohm resistor, the Arduino Uno, and the power source. The FSR is connected to the analog input pin A0 on the Arduino Uno. The other end of the FSR is connected to the 10k ohm resistor, which is then connected to the ground (GND) pin on the Arduino.

The FSR and the 10k ohm resistor form a voltage divider circuit, where the voltage across the FSR is measured by the analog input pin on the Arduino. When a force is applied to the FSR, the resistance changes, which causes a change in voltage across the FSR. This change in voltage is then read by the Arduino and can be used to determine the force being applied.

In summary, the circuit diagram for the FSR connected to an Arduino Uno using a 10k ohm resistor is a simple setup that allows the Arduino to read the changes in resistance from the FSR, which can be used to determine the force being applied.

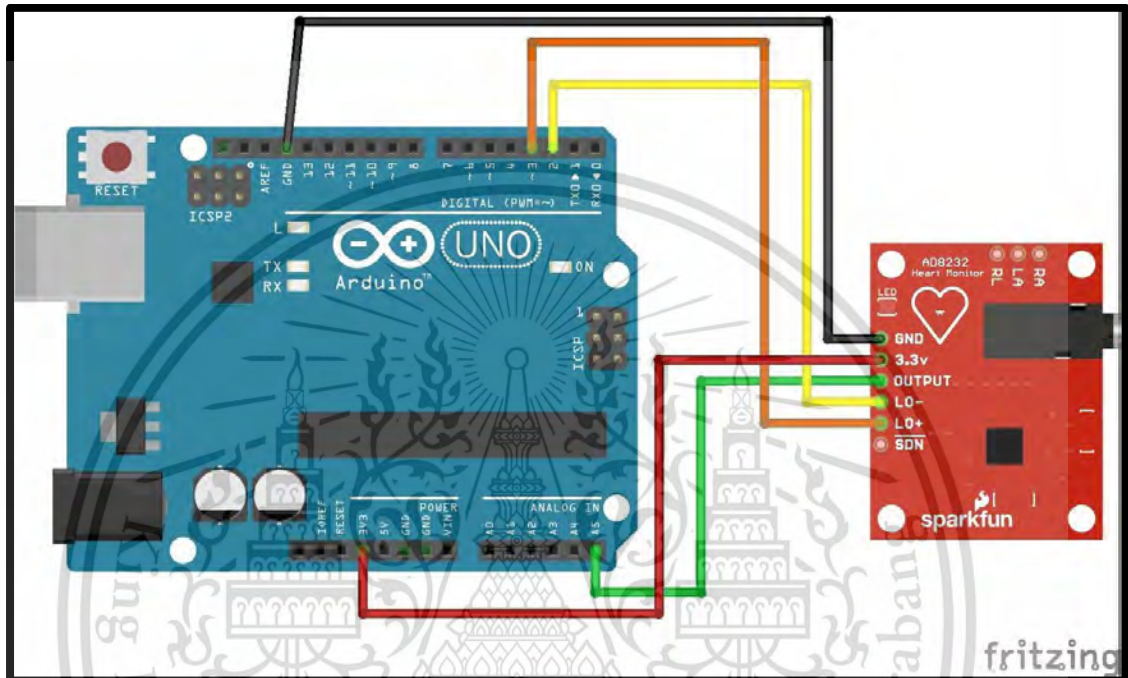

**Figure 3.5.3: Circuit diagram for ECG module [157]**

An ECG (**Figure 3.5.3**) module is an electronic device used to measure and record the electrical activity of the heart. The circuit diagram for an ECG module consists of several components, including electrodes, an instrumentation amplifier, a low-pass filter, a high-pass filter, and an Arduino microcontroller.

The ECG electrodes are placed on the patient's chest to capture the electrical signals generated by the heart. The signal from the electrodes is then amplified by the instrumentation amplifier to increase the strength of the signal.

The amplified signal then passes through a low-pass filter, which removes high-frequency noise from the signal. This helps to ensure that the ECG signal is clean and accurate.

Next, the signal passes through a high-pass filter, which removes any low-frequency noise from the signal. This helps to further improve the quality of the ECG signal.

Finally, the filtered ECG signal is sent to the Arduino microcontroller for processing and display. The Arduino can be programmed to display the ECG waveform in real-time on a computer screen or to record the data for later analysis.

Overall, the circuit diagram for an ECG module is designed to accurately measure and record the electrical activity of the heart, which can be used for medical diagnosis and treatment.

### 3.6 Hardware part

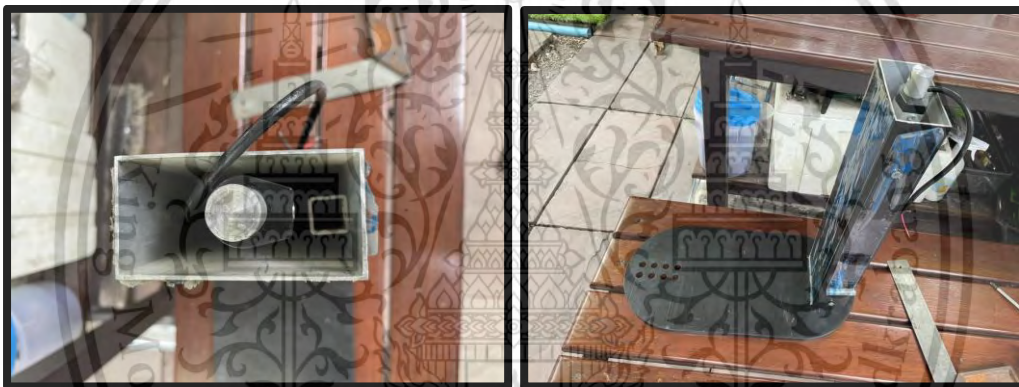

**Figure 3.6.1: Second linear actuator installation**

When installing the second linear actuator, it is important to ensure that it is well-supported and secure, as it will be responsible for moving the motor holder. A 20-centimeter steel rod is a good choice for support, as it is strong enough to handle the weight of the motor holder and provides stability. However, simply attaching the linear actuator to the steel rod is not enough. To further enhance its stability and prevent any potential damage, a 2 in x 4 in black steel box can be used to cover and protect the linear actuator as shown in **Figure 3.6.1**. This will help prevent any accidental bumps or knocks that could cause the linear actuator to move or become damaged. Overall, the combination of the steel rod and steel box provides a sturdy and reliable installation for the second linear actuator, ensuring that it can effectively and safely operate the motor holder.



*Figure 3.6.2: The Automatic CPR machine*

The automatic CPR machine (*Figure 3.6.2*) is a device designed to provide continuous chest compressions to a person in cardiac arrest. It is an essential tool used by medical professionals to help resuscitate patients who have stopped breathing or have no pulse. In order to ensure the smooth and efficient operation of the device, it is necessary to have a secure and stable platform for the motor and microcontroller devices.

To achieve this, a small circuit box is installed to house and secure all the microcontrollers and other electronic components needed to operate the device. This helps to protect the components from damage and also reduces the risk of loose connections or other issues that could interfere with the proper functioning of the machine.

Additionally, a linear rail is used to secure the top and bottom parts of the machine to prevent shaking during operation. This helps to ensure that the device remains stable and that the motor can operate smoothly without any unnecessary vibrations or movements.

Overall, these measures help to ensure the reliable and effective operation of the automatic CPR machine, making it an essential tool for saving lives in emergency situations.

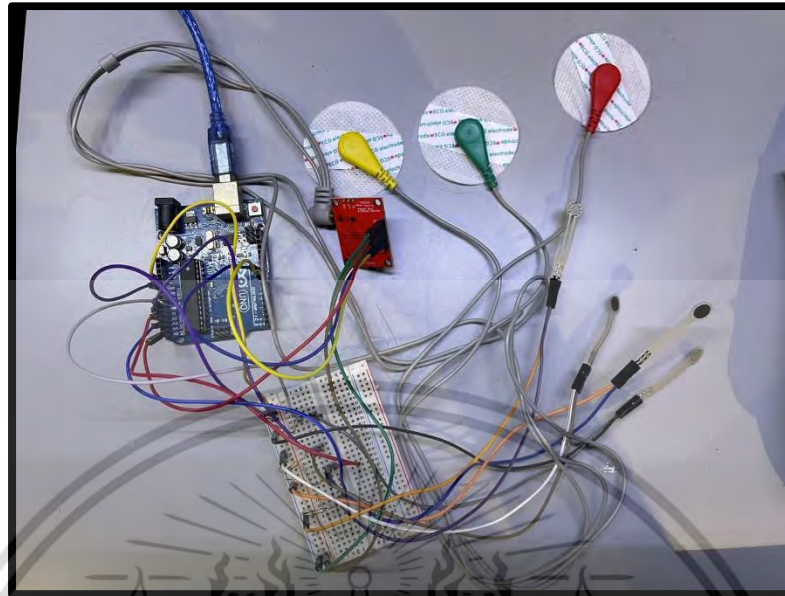

**Figure 3.6.3: ECG module and FSR sensors**

The ECG module is an important component in the automatic resuscitation system that includes the automatic CPR machine, emergency ventilator, and FSR (**Figure 3.6.3**). It is responsible for measuring the electrical activity of the heart and displaying it as a waveform on a screen or through a speaker. This allows medical professionals to monitor the patient's heart rhythm and identify any abnormalities or potential cardiac issues.

The ECG module typically consists of several electrodes that are attached to the patient's chest and connected to the module. These electrodes detect the electrical signals generated by the heart and transmit them to the module, where they are amplified and filtered to produce a clear and accurate ECG waveform.

In addition to the ECG module, the automatic resuscitation system also includes the FSR to measure the force induced onto the patient during chest compressions. The device consists of four FSRs to measure the force at four different angles of the rubber surface. This allows for more accurate measurements and helps ensure that the correct amount of force is being applied during CPR.

ECG-synchronized CPR hardware consists of specialized electrodes that are strategically placed on the patient's body to capture and transmit the

This material is reserved for educational use only, not allowed for commercial use.

Forbidden to modify the content, and cite the document when use.

electrical signals of the heart. In this specific setup, the green electrode is attached to the right leg, the red electrode to the right arm, and the yellow electrode to the left arm. These electrodes serve as the input interface for the ECG module, which processes the electrical activity of the heart and generates the ECG waveform. The ECG waveform is then analyzed in real-time by the CPR hardware, which includes a control unit and actuation mechanism. The control unit interprets the ECG signal, detects the R wave, and triggers the chest compressions at the appropriate time. The actuation mechanism is responsible for delivering the compressions with the desired force and depth. By synchronizing the CPR actions with the ECG signal, this hardware setup optimizes the effectiveness of CPR by aligning it with the patient's cardiac rhythm, improving the chances of successful resuscitation.

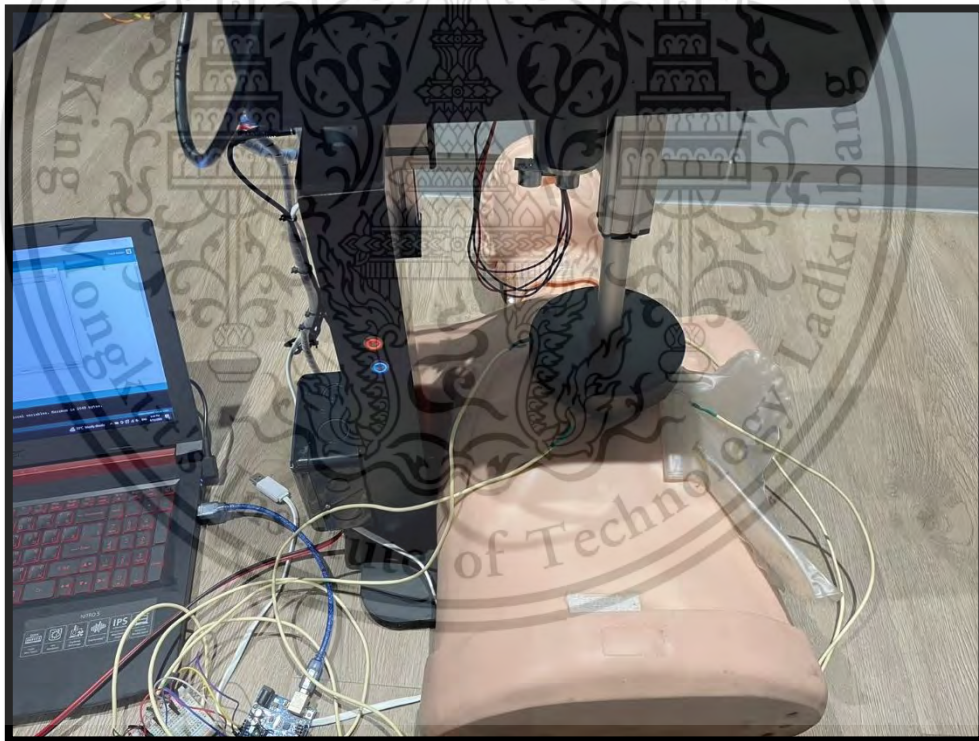

**Figure 3.6.4: FSR sensors position**

In *Figure 3.6.4*, a visual representation showcases the strategic placement of the FSR sensors to accurately measure the force exerted during compression in the device. With the utilization of four force sensors, we are able to assess the balance of force distribution during the compression process. When

This material is reserved for educational use only, not allowed for commercial use.

Forbidden to modify the content, and cite the document when use.

the force is imbalanced, the FSR values will exhibit variations among the sensors. These FSR sensors are positioned underneath the rubber component that comes into contact with the patient's chest. The incorporation of FSR sensors enables us to not only monitor the force applied to the patient but also ensure its appropriateness. If the FSR readings indicate an excessive force being exerted, the device will promptly cease operation to mitigate the risk of potential chest injuries to the patient.

Known Weight (kg)	FSR Reading
0	686
1.5	635
3	542
5	437
7	355
8	310
10	294

**Table 3.6.5: FSR sensors calibration**

By using the Arduino code calculates the force exerted on four FSR sensors and converts the analog readings to force values in kilograms (**Table 3.6.5**). The principle behind the conversion involves measuring the resistance of the FSR sensors using voltage readings. By applying a known relationship between resistance and force, the code calculates the force exerted on each FSR sensor. The resistance values are then used to derive force values in kilograms through a mathematical equation. These force values are subsequently printed to the Serial monitor. This process enables the system to measure and display the force applied to the FSR sensors in a standardized unit of kilograms, providing valuable information about the pressure exerted on the sensors during the operation of the device.

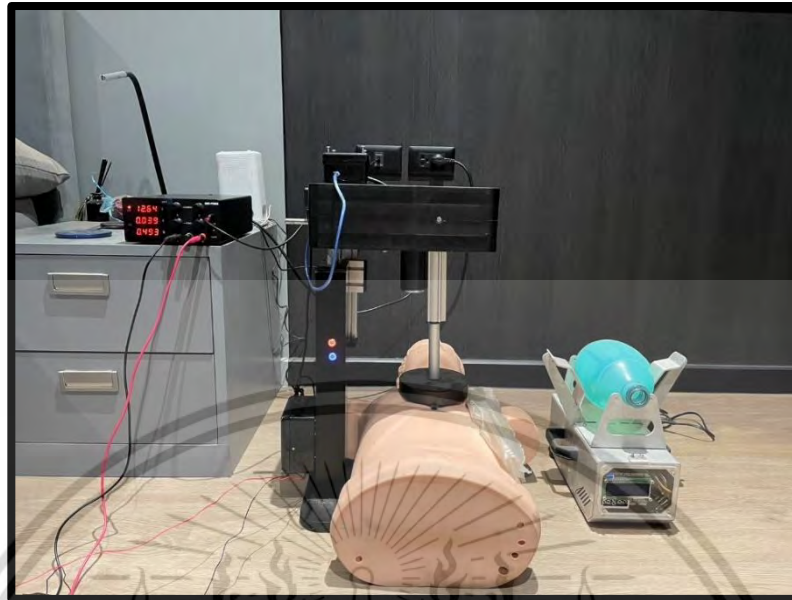

**Figure 3.6.6: Total assembly of the automatic CPR system**

The automatic resuscitation system (*Figure 3.6.6*) consists of several components that work together to provide life-saving measures during a cardiac arrest or respiratory failure. The main components of the system include the automatic CPR machine, emergency ventilator, ECG module, and FSR sensors.

The automatic CPR machine is designed to perform chest compressions on the patient during cardiopulmonary resuscitation (CPR). It includes a linear actuator, motor driver, and a microcontroller such as an Arduino, along with various sensors and switches to control the speed and force of the compressions.

The ECG module is used to monitor the patient's heart activity and detect any abnormalities or changes that may occur during resuscitation. It includes a set of electrodes that are placed on the patient's chest, which detect the electrical signals produced by the heart and transmit them to the microcontroller for analysis and display. The integration of ECG synchronization with an automatic CPR system enhances the precision and effectiveness of cardiac resuscitation efforts. By aligning the chest compressions with the electrical activity of the heart, as indicated by the ECG signal, the system ensures that compressions are delivered during the optimal phase of the cardiac cycle. This synchronization maximizes blood flow to vital organs, minimizes the risk of triggering harmful cardiac rhythms, and provides real-time feedback on the quality of

compressions. ECG synchronization with the automatic CPR system improves the chances of successful resuscitation and contributes to better patient outcomes in cases of cardiac arrest.

Lastly, the FSR sensors are used to measure the force applied to the patient's chest during CPR, which can help ensure that the compressions are effective and minimize the risk of injury to the patient. The FSR sensors are placed on a rubber surface that covers the patient's chest, and they measure the force applied at four different angles.

Overall, the combination of these components provides a comprehensive and effective system for performing resuscitation in emergency situations.

### **3.7 Optical-Based Pressure Measurement System**

The utilization of an Optical-Based Pressure Measurement System offers valuable insights into the pressure distribution exerted on the patient during various activities. This innovative system provides a real-time, cost-effective, and marker-free approach to measuring plantar pressure, enabling analysis in human postural control, gait analysis, and recognition studies.

The Optical-Based Pressure Measurement System comprises a setup of digital cameras installed beneath an acrylic-top platform. Along the sides of the acrylic plate, an LED strip is mounted, which emits light that is deflected by the pressure applied between the glossy white paper on top of the acrylic plate and the acrylic plate itself. This deflection of light is captured by the digital cameras, resulting in a color-coded image that represents the plantar pressure distribution of the subject standing on the platform [158].

The system incorporates a series of USB cameras aligned under the acrylic-plate walking platform, and a mosaic image processing technique is employed to concatenate the captured images, thereby increasing the sensing area. By capturing the image data in video mode, various dynamic parameters can be derived for further analysis of the subject's dynamic movement. Additionally, individual frames from the captured images can be used for static analysis of the plantar pressure distribution [158].

The applications of this Optical-Based Pressure Measurement System extend to human postural measurement, gait analysis, and person identification. Its versatility and comprehensive nature make it an all-in-one solution for measuring pressure in various contexts. By utilizing this system, healthcare professionals and researchers can gain valuable insights into the pressure distribution patterns exerted on the patient's feet during different activities, providing essential information for optimizing interventions, improving gait analysis techniques, and enhancing individual identification methods [158].

The incorporation of an Optical-Based Pressure Measurement System in automatic CPR systems offers significant advantages in understanding the pressure distribution on the patient's feet. This system provides real-time, marker-free measurement capabilities, allowing for comprehensive analysis of plantar pressure in human postural control, gait analysis, and person identification. Its ability to capture dynamic and static plantar pressure data makes it an invaluable tool for optimizing treatments, refining gait analysis techniques, and developing personalized care strategies.

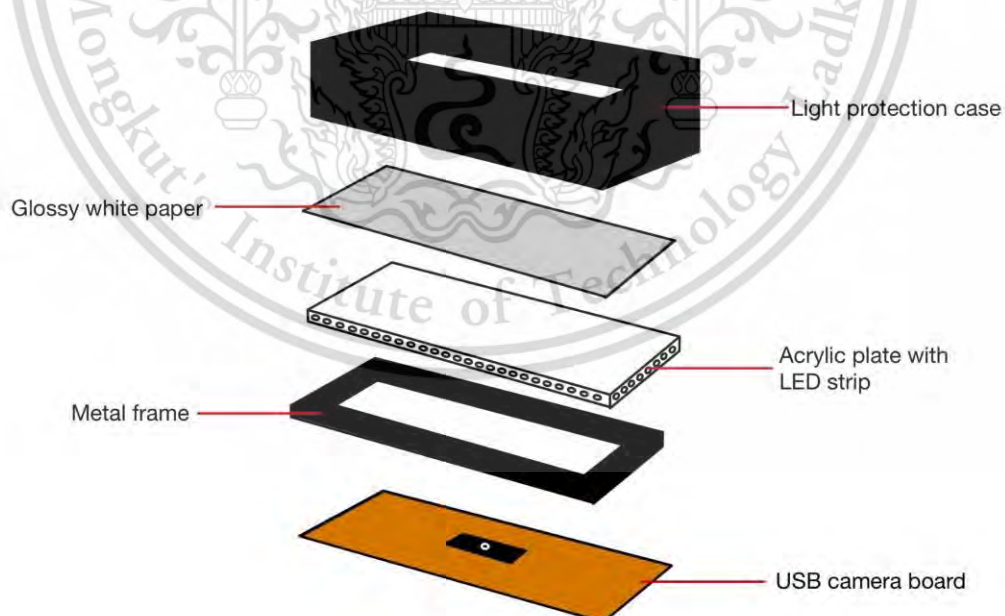

**Figure 3.7: Design of optical-based pressure measurement device [158]**

In our particular scenario, we have opted to utilize a single camera instead of employing all the USB cameras available in the optical-based plantar-

This material is reserved for educational use only, not allowed for commercial use.

Forbidden to modify the content, and cite the document when use.

pressure measurement device (*Figure 3.7*). This decision is based on factors such as cost-effectiveness and simplicity of implementation. By utilizing a single camera, we aim to achieve a more streamlined and efficient setup while still obtaining valuable data and insights regarding pressure distribution.

### 3.8 Proposed Solution

The automatic resuscitation system includes integrating the automatic CPR machine, emergency ventilator, ECG module, and FSR sensors into a single system powered by a reliable power supply. The power supply should be able to provide enough power to run all the components of the system without any interruptions or failures. Additionally, the power supply should be designed to include a backup power source to ensure uninterrupted operation in case of power outages or other unforeseen events.

The system should be designed to include a microcontroller unit that will control the overall functioning of the system. The microcontroller should be programmed to receive inputs from the ECG module and the FSR sensors to monitor the patient's heart rate, breathing rate, and force applied during chest compressions. Based on these inputs, the microcontroller will send signals to the automatic CPR machine and emergency ventilator to adjust the compression rate, ventilation rate, and other parameters as needed.

The automatic CPR machine will provide chest compressions at a constant rate, while the emergency ventilator will provide artificial respiration to the patient. The ECG module will measure the patient's heart rate and rhythm, providing critical information for diagnosis and treatment. The FSR sensors will measure the force exerted on the patient during CPR, providing valuable feedback on the effectiveness of chest compressions. The system will be powered by a 12V power supply, making it portable and convenient to use in emergency situations.

To ensure reliability and accuracy, the system will be designed with high-quality components and undergo rigorous testing and validation. The automatic CPR machine and emergency ventilator will be designed with a compact and robust form factor to ensure ease of use and portability. The ECG

module and FSR sensors will be designed with a high level of sensitivity and accuracy to provide reliable measurements.

Finally, the system should be designed to be portable and easy to transport. The system should also be designed to be easily disassembled and assembled, making it easy to transport to different locations. The proposed solution aims to provide a comprehensive and effective resuscitation system that can save lives in emergency situations. With its advanced features and ease of use, the system has the potential to revolutionize the field of emergency medicine and improve patient outcomes.

### **3.9 Summary**

Chapter 3 delves into the installation, design, circuit diagram, and mobile app interface of the automatic cardiopulmonary resuscitation (CPR) machine. The chapter begins by providing an overview of the installation process, including the necessary considerations and requirements for setting up the system. It emphasizes the importance of proper installation to ensure optimal performance and functionality.

Next, section 3.3 focuses on the design aspect of the automatic CPR machine. It explores the design principles, guidelines, and considerations taken into account during the development of the system. The chapter highlights the importance of ergonomic design, user-friendly interfaces, and integration of key features to enhance the usability and effectiveness of the CPR machine.

Continuing further, section 3.4 focuses on the mobile app interface design. It discusses the design principles and considerations employed to create a user-friendly and intuitive interface for controlling and monitoring the automatic CPR machine. The chapter highlights the key features, functionalities, and visual elements of the mobile app interface, emphasizing its role in enhancing the user experience and facilitating efficient operation of the system.

In section 3.5, the chapter introduces the circuit diagram, which serves as a blueprint for the electrical connections and components of the automatic CPR machine. It provides a comprehensive visual representation of the

circuitry, highlighting the interconnections, power supply, and control mechanisms involved. The circuit diagram serves as a vital reference for understanding the electrical infrastructure of the CPR machine.

Section 3.6 explores the hardware assembly of the automatic CPR machine. It provides a detailed account of the step-by-step process involved in assembling the hardware components, ensuring proper alignment, secure connections, and reliable functionality. The chapter discusses any challenges encountered during the assembly process and provides insights into best practices for successful hardware integration.

Section 3.7 introduces the Optical-Based Plantar Pressure Measurement System, a critical component of the automatic CPR device, designed to measure pressure during chest compressions. The system utilizes a USB camera and image processing techniques to capture and analyze pressure distribution. The image is processed using MATLAB, allowing for the calculation of pressure values.

Overall, Chapter 3 encompasses the crucial aspects of installation, design, circuit diagram, mobile app interface, and hardware assembly of the automatic CPR machine. It provides a comprehensive understanding of the system's setup, design principles, electrical infrastructure, user interface, and physical assembly. This chapter sets the stage for the subsequent chapter, where the experimental results and performance evaluation of the automatic CPR machine will be presented.

## **CHAPTER 4**

### **EXPERIMENTAL RESULTS**

#### **4.1 Introduction**

Chapter 4 presents the experimental results and performance evaluation of the automatic cardiopulmonary resuscitation (CPR) machine. This chapter focuses on providing a comprehensive analysis of the machine's real-world performance, including its ability to deliver effective compressions, monitor vital signs, and interact with the user through the mobile app interface. The pressure map results provide valuable insights into force distribution during CPR, while the ECG synchronized CPR device offers a novel approach to chest compressions, synchronized with the patient's ECG signal, potentially improving the effectiveness of resuscitation efforts. By evaluating the machine's performance, this chapter aims to validate its functionality and assess its effectiveness in performing automated CPR.

#### **4.2 Evaluation**

The automatic resuscitation system represents a significant advancement in the field of emergency medical care, aiming to improve the efficiency and effectiveness of cardiopulmonary resuscitation (CPR). This evaluation seeks to assess the system's performance, highlighting its strengths, limitations, and potential areas for improvement.

##### **4.2.1 Performance and Effectiveness:**

**Proper Compression Position:** The automatic resuscitation system demonstrated its ability to compress the chest at the proper position. This is crucial for effective CPR, as it ensures optimal blood circulation and increases the chances of successful resuscitation.

**Reduced Force on the Patient:** By incorporating a rubber surface and optimizing the design, the system successfully mitigated the risk of rib fractures.

This is a significant improvement, as it enhances patient safety and minimizes potential complications during the resuscitation process.

**Controlled Compression Depth:** The average depth of chest compressions, within the range of 4-5 cm, falls within an acceptable range. This indicates that the system can deliver consistent compression depth, which is vital for achieving adequate perfusion and restoring normal cardiac function.

**Mobile App Control Interface:** The integration of a mobile app control interface, utilizing App Inventor, offers convenient and wireless control over the system. This enhances user accessibility and enables precise adjustments and monitoring during CPR procedures.

#### **4.2.2 Limitations and Areas for Improvement:**

**Compression Rate Variability:** During testing, the compression rate of the linear actuator motor exhibited variability, ranging from 60 to 75 compressions per minute (CPM). This falls slightly below the desired range of 80 to 120 CPM. To improve system performance, efforts should focus on achieving a more consistent compression rate within the recommended range.

**Compression Depth Consistency:** While the average compression depth is acceptable, the system showed inconsistency in maintaining a steady compression depth. To enhance performance, further research and development are needed to ensure more consistent and reliable compression depths throughout the resuscitation process.

**Real-World Evaluation:** Although the system demonstrated promising results in controlled experimental settings, it is crucial to conduct additional clinical trials and evaluations in real-world scenarios. This will provide valuable insights into the system's performance, usability, and safety when applied in actual emergency situations.

**Collaboration and Standardization:** To ensure widespread adoption and integration of the automatic resuscitation system, collaboration with medical professionals and organizations is essential. Establishing guidelines and standards for its usage, along with regulatory compliance, will enhance its

credibility and facilitate seamless integration into existing emergency medical protocols.

The automatic resuscitation system has shown promise in improving the efficiency and effectiveness of CPR procedures. Its ability to compress the chest at the proper position, reduce force on the patient, and provide controlled compression depths signifies its potential to enhance patient outcomes during resuscitation efforts. However, addressing the variability in compression rate and ensuring consistent compression depths remain important areas for further improvement. Conducting real-world evaluations, collaborating with medical professionals, and standardizing its usage are crucial steps toward realizing the system's full potential and ensuring its safe and effective deployment in emergency medical settings. Through continuous research, development, and collaboration, the automatic resuscitation system can play a vital role in advancing emergency medical care and improving patient survival rates.



*Figure 4.2: Hand position*

In order to improve the effectiveness and safety of the automatic cardiopulmonary resuscitation equipment, in **Figure 4.2** the rubber surface of the device has been enlarged. This design modification aims to decrease the amount of force applied to the patient's chest during compressions, which in turn reduces the risk of rib fracture. The enlarged rubber surface also allows the device to compress at the correct compression position, which is critical for successful cardiopulmonary resuscitation. The device is designed to work in conjunction with an emergency ventilator and an ECG module to provide a comprehensive resuscitation solution. The ECG module monitors the patient's heart rhythm and provides real-time feedback to the rescuer, while the

This material is for personal use only; all rights reserved. No part of this document may be reproduced, stored in a retrieval system, or transmitted in any form or by any means, electronic, mechanical, photocopying, recording, or by any information storage and retrieval system, without the prior written permission of the copyright owner.

Forbidden to modify the content, and cite the document when use.

emergency ventilator provides oxygen to the patient's lungs. All of these components are controlled via a mobile app, making it easy for rescuers to adjust settings and monitor the patient's condition during resuscitation efforts.

In addition to the design modifications mentioned above, the automatic cardiopulmonary resuscitation equipment is also equipped with FSR sensors to measure the force applied to the patient's chest during compressions. The device has four FSR sensors located on the rubber surface, which measure the force at four different angles. This allows the device to provide accurate feedback on the amount of force being applied and adjust the compression depth accordingly.

The device is powered by a reliable power supply, which ensures that it can be used for extended periods of time without interruption. The device is also designed with safety in mind and includes a circuit box to secure all microcontrollers and other electronic components. A linear rail is used to secure the top and bottom parts of the device, which prevents shaking and ensures stable and consistent compressions.

Overall, the automatic resuscitation system consisting of the automatic CPR machine, emergency ventilator, ECG module, and FSR sensors is a comprehensive and effective solution for cardiopulmonary resuscitation. The use of a mobile app to control the system makes it user-friendly and easy to operate, while the various safety features and design modifications make it safe and effective for use in emergency situations.

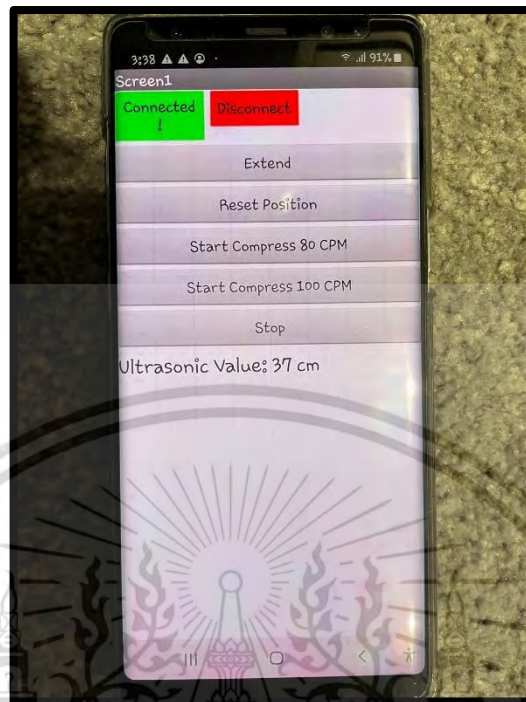

**Figure 4.2.1: Ultrasonic display on mobile phone**

**Figure 4.2.1** illustrates the App Inventor interface displayed on a smartphone, showcasing the control options available for the automatic CPR device. The app enables users to operate the compression function of the device while providing real-time feedback through the display of ultrasonic values. Upon successful Bluetooth connection, the connect button dynamically changes to "Connect!" to indicate the established connection. Conversely, the disconnect button allows users to disconnect the Bluetooth connection when desired.

The operating section of the app comprises five buttons, each serving a specific function.

The "Extend" button enables users to extend the linear actuator to its maximum length, allowing for increased compression range during CPR procedures.

The "Reset Position" button allows users to retract the linear actuator back to its minimum length, providing a starting point for subsequent compression cycles.

Pressing the "Start Compress" button initiates the operation of the linear actuator, engaging it to compress the chest at the desired position determined by the

linear actuator. Pressing the button again stops the operation, providing control and flexibility during CPR procedures.

The "Stop" button enables users to halt the linear actuator at the desired length, allowing for manual adjustments or specific positioning requirements based on individual patient needs.

By incorporating these intuitive control options within the App Inventor interface, users can effectively operate and manipulate the automatic CPR device according to their preferences and the specific requirements of the resuscitation scenario. The user-friendly interface, coupled with real-time feedback through the display of ultrasonic values, enhances the overall usability and effectiveness of the automatic resuscitation system.

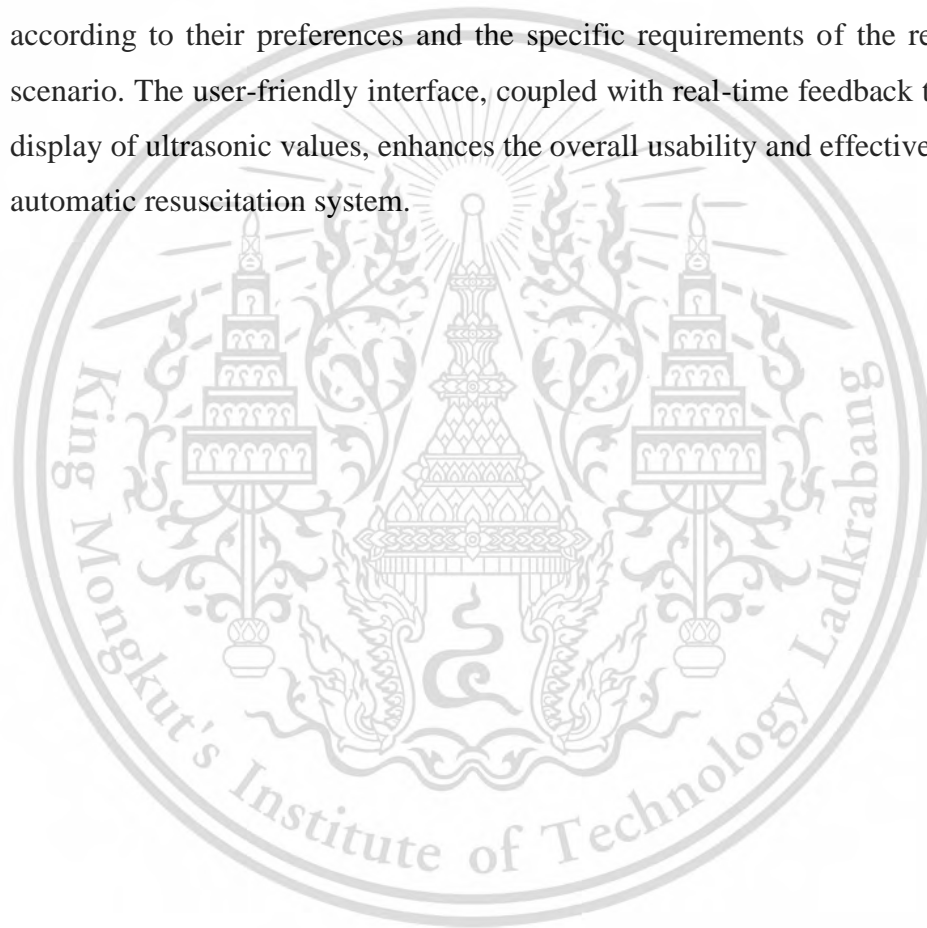

### 4.3 Compression result

The utilization of ultrasonic technology plays a crucial role in determining the depth of chest compression in the automatic resuscitation system. By integrating an ultrasonic sensor into the device, accurate measurements of the compression depth can be obtained. The ultrasonic sensor emits high-frequency sound waves that travel through the chest and bounce back upon encountering a surface, which in this case is the chest cavity.

The received sound waves are then analyzed by the system, allowing it to calculate the distance between the sensor and the chest. This distance is directly proportional to the depth of chest compression, providing valuable information for monitoring and ensuring the effectiveness of the resuscitation procedure.

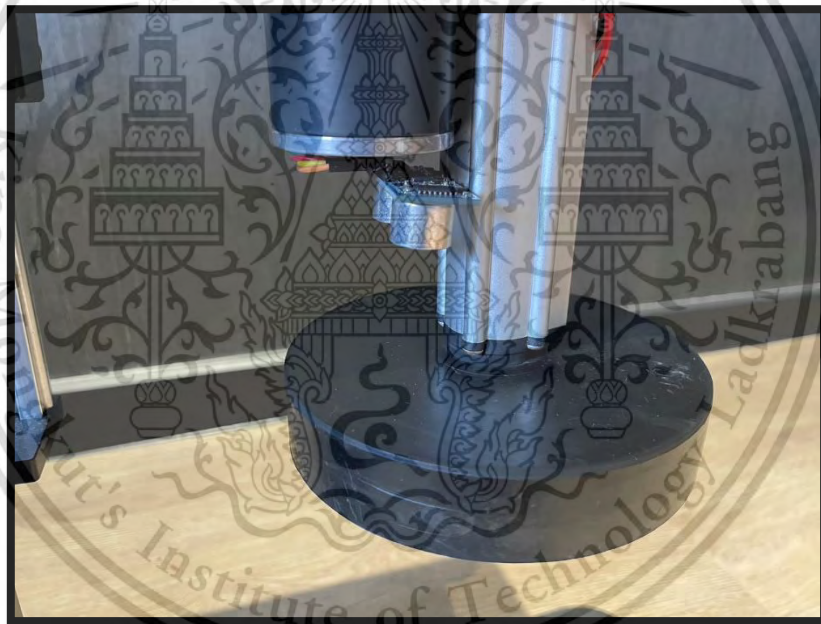

*Figure 4.3: Ultrasonic position*

To present this data to the user, the mobile phone App Inventor interface displays the ultrasonic sensor installed at linear actuator to measure the distance and display value on the screen (*Figure 4.3*). This real-time feedback allows medical personnel or responders to monitor the depth of chest compression during CPR operations. By observing the displayed values, they can assess whether the compression depth is within the desired range and make necessary adjustments if needed.

The integration of the ultrasonic value display within the App Inventor interface provides an accessible and user-friendly means of monitoring the effectiveness of chest

This material is reserved for educational use only, not allowed for commercial use.

Forbidden to modify the content, and cite the document when use.

compressions. It allows healthcare professionals to ensure that the appropriate compression depth is achieved, as deviations from the recommended range can impact the efficiency of resuscitation efforts. Additionally, the displayed ultrasonic values serve as an objective measure of the compression depth, providing valuable data for analysis and evaluation during post-event reviews or research studies.

The integration of ultrasonic technology and the display of ultrasonic values on the mobile phone App Inventor interface enhance the automatic resuscitation system's ability to deliver accurate and reliable chest compressions. This feature enables healthcare providers to make informed decisions, optimize the quality of CPR procedures, and potentially improve patient outcomes.

COM7	COM7	COM7
Compression Depth: 10	Compression Depth: 12	Compression Depth: 11
Compression Depth: 11	Compression Depth: 14	Compression Depth: 13
Compression Depth: 11	Compression Depth: 10	Compression Depth: 13
Compression Depth: 11	Compression Depth: 14	Compression Depth: 11
Compression Depth: 13	Compression Depth: 11	Compression Depth: 13
Compression Depth: 13	Compression Depth: 12	Compression Depth: 11
Compression Depth: 15	Compression Depth: 12	Compression Depth: 15
Compression Depth: 13	Compression Depth: 13	Compression Depth: 12
Compression Depth: 13	Compression Depth: 10	Compression Depth: 11
Compression Depth: 13	Compression Depth: 15	Compression Depth: 14
Compression Depth: 13	Compression Depth: 12	Compression Depth: 13
Compression Depth: 10	Compression Depth: 10	Compression Depth: 13
Compression Depth: 11	Compression Depth: 10	Compression Depth: 11
Compression Depth: 12	Compression Depth: 13	Compression Depth: 13
Compression Depth: 11	Compression Depth: 13	Compression Depth: 10
Compression Depth: 10	Compression Depth: 13	Compression Depth: 14
Compression Depth: 12	Compression Depth: 10	Compression Depth: 12
Compression Depth: 12	Compression Depth: 10	Compression Depth: 11
Compression Depth: 10	Compression Depth: 10	Compression Depth: 14
Compression Depth: 13	Compression Depth: 15	Compression Depth: 14
Compression Depth: 11	Compression Depth: 10	Compression Depth: 12
Compression Depth: 13	Compression Depth: 13	Compression Depth: 14
Compression Depth: 13	Compression Depth: 12	Compression Depth: 11
Compression Depth: 14	Compression Depth: 12	Compression Depth: 14
Compression Depth: 11	Compression Depth: 12	Compression Depth: 14
Compression Depth: 12	Compression Depth: 11	Compression Depth: 10
Compression Depth: 14	Compression Depth: 12	Compression Depth: 14
Compression Depth: 13	Compression Depth: 10	Compression Depth: 11
Compression Depth: 12	Compression Depth: 14	Compression Depth: 10
Compression Depth: 15	Compression Depth: 11	Compression Depth: 15

**Table 4.3: Ultrasonic data on serial monitor**

**Table 4.3** provides a comprehensive overview of the ultrasonic data recorded and displayed on the Arduino serial monitor. The values obtained from the ultrasonic sensor range from 10 cm to 15 cm, indicating the distance between the sensor and the chest during the compression phase.

Analyzing the data, it can be observed that the compression distance falls within a range of approximately 5 cm. However, it is important to note that these values may not precisely reflect the actual depth of compression on the patient's chest.

This material is reserved for educational use only, not allowed for commercial use.

Forbidden to modify the content, and cite the document when use.

There are several factors that can contribute to potential inaccuracies in the measured depth. One factor is the position and placement of the ultrasonic sensor on the device. It is crucial to ensure that the sensor is correctly positioned and aligned with the chest to obtain the most accurate readings. Any misalignment or inconsistencies in the sensor's placement may result in variations in the measured values.

Additionally, the presence of external factors such as clothing or other materials on the patient's chest can affect the accuracy of the ultrasonic measurements. These external elements can interfere with the sound waves emitted by the sensor, leading to potential deviations in the recorded data.

It is important to interpret the ultrasonic data in the context of these limitations and consider them as an estimation rather than an absolute measurement of the compression depth. Healthcare professionals should exercise caution when relying solely on the displayed ultrasonic values and utilize additional clinical judgment and assessment to ensure proper chest compression depth during resuscitation efforts.

Further research and development may be necessary to improve the accuracy and reliability of the ultrasonic measurements in the automatic resuscitation system. This could involve refining the sensor placement and calibration techniques, as well as exploring alternative or complementary technologies to validate and cross-reference the measured compression depth. By addressing these challenges, more precise and consistent measurements can be achieved, leading to enhanced patient care and improved outcomes during CPR procedures.

The average depth of chest compression, as indicated by the results presented in **Table 4.3**, is approximately 4-5 cm. While this falls within an acceptable range, the measurements were not consistent and showed variations. This suggests that there is room for improvement in achieving a more steady compression depth. Factors such as the mechanical characteristics of the linear actuator motor, the device's positioning on the patient's chest, and external variables may contribute to the observed fluctuations. Further research and development efforts should be focused on refining the system's design, exploring alternative actuation mechanisms, and implementing feedback control mechanisms to ensure more precise and consistent compression depths. By addressing these challenges,

This material is reserved for educational use only, not allowed for commercial use.

Forbidden to modify the content, and cite the document when use.

the automatic resuscitation system can enhance the effectiveness of CPR and improve patient outcomes.

#### **4.4 The compression rate**

The evaluation of the linear actuator motor's compression rate reveals some important findings. When the motor is set to operate at 80 compressions per minute (CPM), the observed compression rate ranged from 75 to 80 CPM. Similarly, when the motor was set to operate at 100 CPM, the compression rate varied between 90 and 100 CPM. It is worth noting that the desired range for chest compression rate during cardiopulmonary resuscitation (CPR) is typically set between 80 and 120 CPM.

The observed compression rates fall within the acceptable range during both settings. However, there is a noticeable discrepancy between the desired compression rate and the actual compression rate achieved by the linear actuator motor. This discrepancy suggests that further improvements are necessary to ensure that the compression rate aligns more closely with the desired range.

To achieve a more consistent and accurate compression rate, various factors need to be considered and addressed. These factors may include optimizing the motor control algorithms, improving the responsiveness and precision of the motor, and refining the mechanical components of the system. By fine-tuning these aspects, the automatic resuscitation system can achieve the desired compression rate range of 80 to 120 CPM, leading to more effective CPR procedures and potentially better patient outcomes.

The evaluation of the linear actuator motor's compression rate reveals that although the observed rates during testing fall within an acceptable range, they do not consistently align with the desired compression rate range. Further improvements and refinements are necessary to ensure that the motor can consistently achieve the desired compression rate range during CPR procedures.

## 4.5 FSR result

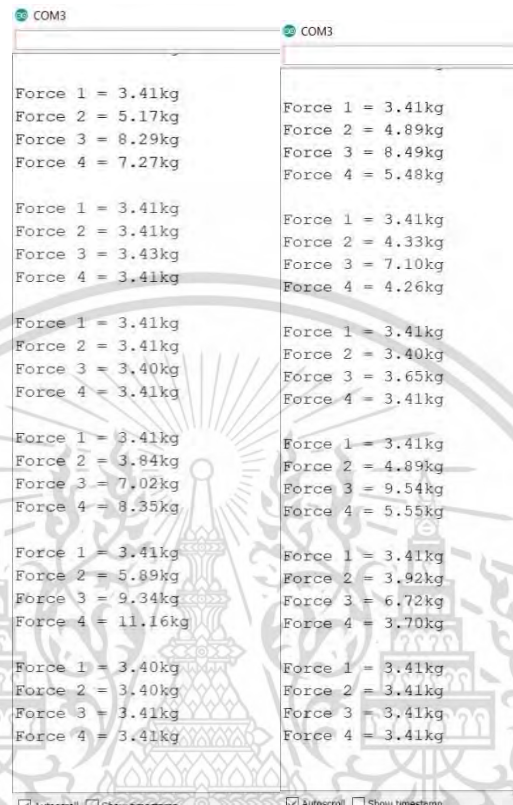

**Figure 4.5: FSR results on serial monitor**

The evaluation of the FSR (force-sensitive resistor) results, as depicted in *Figure 4.5* and analyzed on the Arduino serial plotter, provides insights into the compression force applied to the medical puppet. The results indicate a compression force of approximately 7 kg on the puppet. However, it is important to note that these results may not be entirely accurate due to various factors and variables that can influence the measurements.

One potential factor that can impact the accuracy of the force measurement is the correct mounting and positioning of the force sensor. If the sensor is not properly mounted or if there are any inconsistencies in its placement, it can lead to inaccurate readings. Therefore, it is crucial to ensure precise and secure mounting of the force sensor to obtain reliable and accurate force measurements during chest compressions.

Although the measured force on the medical puppet may appear relatively low, it is essential to consider the ultrasonic detection results, which indicate a change in

distance of approximately 5 cm. This information is crucial as it suggests that the compression depth is within an acceptable range. The combination of force and depth measurements provides a more comprehensive understanding of the compression process and ensures that the applied force is appropriate for effective chest compressions.

To enhance the accuracy and reliability of the force measurements, it is recommended to validate and calibrate the FSR sensor periodically. This calibration process helps to minimize any inaccuracies caused by sensor drift or environmental factors, ensuring more precise and consistent force readings.

The evaluation of the FSR results in Figure 4.5 highlight the compression force applied to the medical puppet during chest compressions. While the recorded force may be subject to potential inaccuracies due to factors such as sensor mounting, the corresponding ultrasonic detection confirms that the compression depth remains within an acceptable range. Calibrating and validating the force sensor periodically can help improve the accuracy of force measurements, ensuring more reliable data for evaluating the performance of the automatic resuscitation system.

#### **4.6 ECG result**

The ECG (Electrocardiogram) data captured by ECG modules provides valuable insights into the electrical activity of the heart and is a crucial component in assessing a patient's cardiac health. ECG signals represent the depolarization and repolarization of the heart muscles, allowing healthcare professionals to diagnose various heart conditions and abnormalities.

In the recorded ECG data, three different heart rates are observed: 30 bpm (beats per minute), 60 bpm, and 120 bpm. Each heart rate reflects a specific physiological state and can provide important information about the patient's cardiovascular system.

#### 4.6.1 ECG result 30 bpm

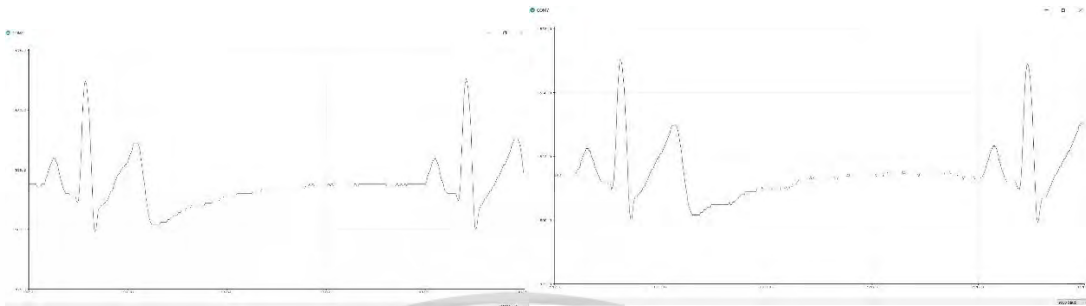

**Figure 4.6.1: ECG results on serial plotter (30 bpm)**

At a heart rate of 30 bpm shown in **Figure 4.6.1**, the ECG signal demonstrates a slow and bradycardic rhythm. Bradycardia can be caused by various factors such as certain medications, sinus node dysfunction, or underlying heart diseases. Monitoring and analyzing the ECG at this rate can aid in diagnosing the cause of the slow heart rate and guiding appropriate treatment options.

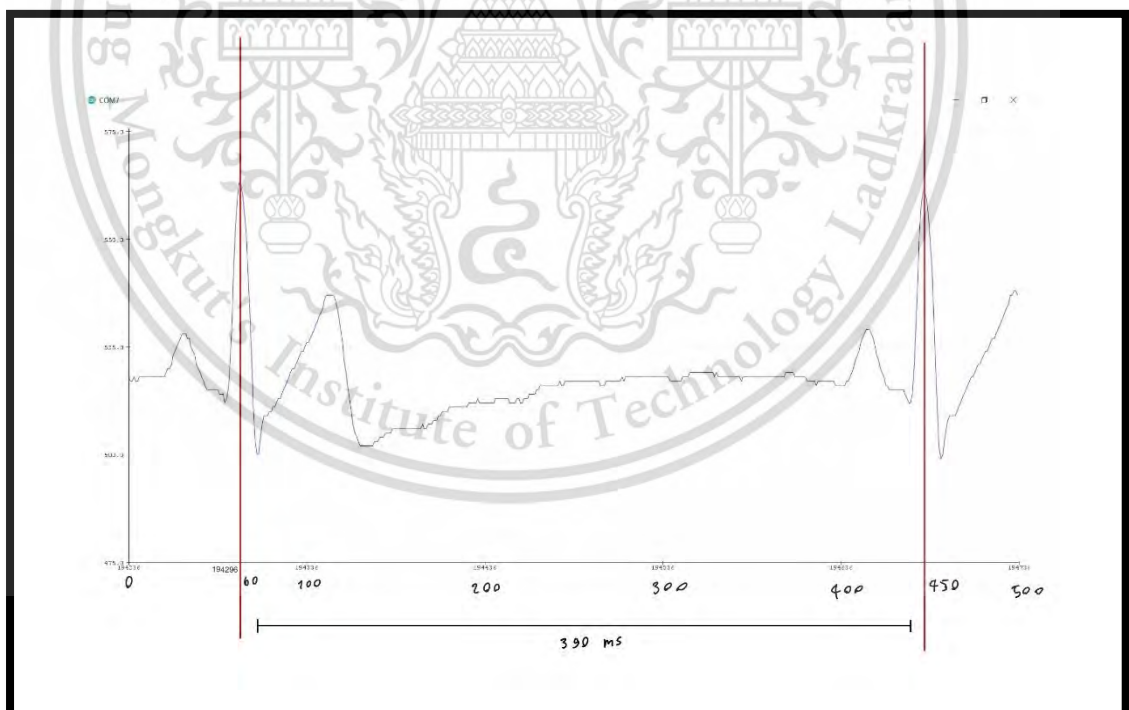

**Figure 4.6.1.2: ECG time delay on serial plotter (30 bpm)**

Within the context of **Figure 4.6.1.2**, the presented ECG signal demonstrates an observable time delay between successive R waves, offering insights into the cardiac activity at a heart rate of 30 beats per minute. Notably,

This material is reserved for educational use only, not allowed for commercial use.

Forbidden to modify the content, and cite the document when use.

the analysis reveals that the interval between two consecutive R waves spans approximately 390 milliseconds. Such findings contribute to a deeper understanding of the temporal characteristics of the ECG waveform and its correspondence to the underlying physiological processes associated with this specific heart rate.

#### 4.6.2 ECG result 60 bpm

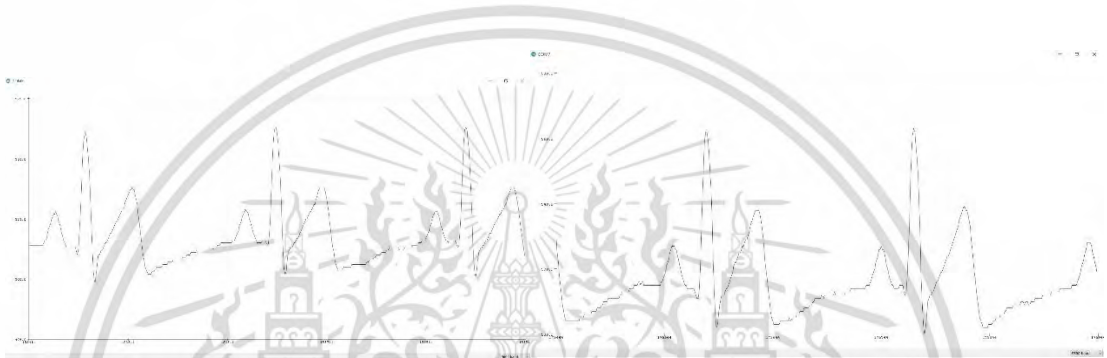

***Figure 4.6.2: ECG results on serial plotter (60 bpm)***

The ECG signal at 60 bpm (*Figure 4.6.2*) represents a normal sinus rhythm, which is considered the standard and healthy heart rate for adults at rest. This rhythm indicates that the heart is functioning properly, with each electrical impulse originating from the sinus node and spreading through the heart in a coordinated manner. A normal sinus rhythm is indicative of a well-regulated cardiac system and is typically associated with optimal cardiac output.

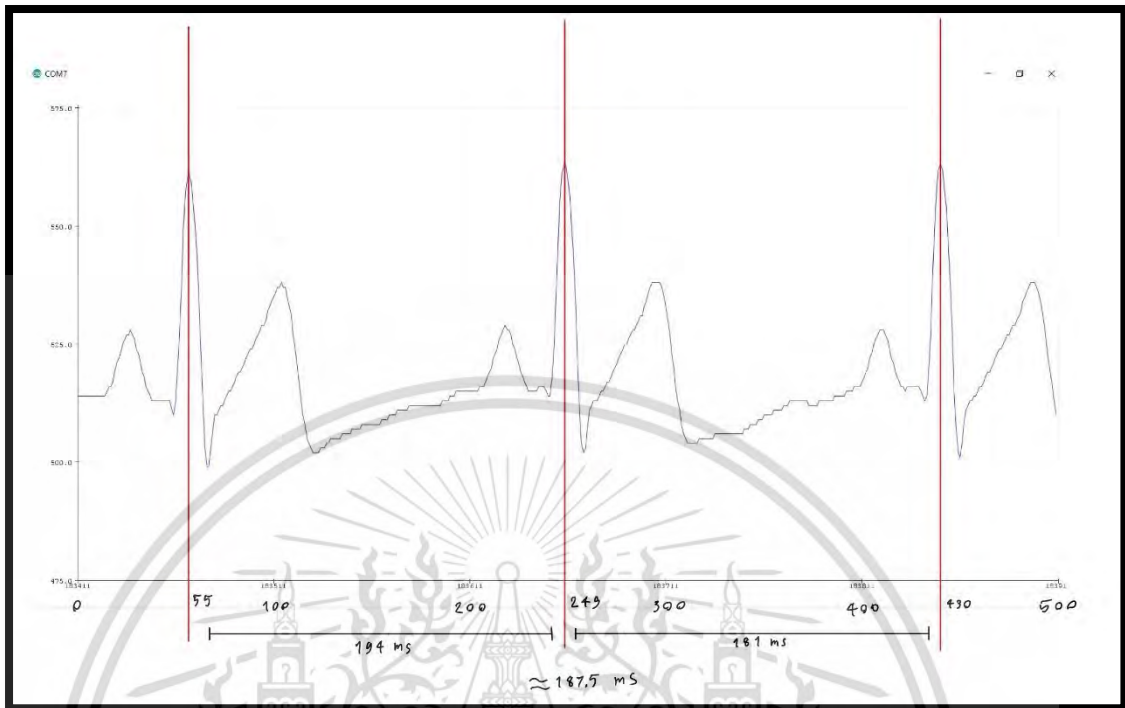

**Figure 4.6.2.2: ECG time delay on serial plotter (60 bpm)**

In **Figure 4.6.2.2**, the ECG signal provides valuable insights into the time delay between successive R waves at a heart rate of 60 beats per minute. The analysis of this result uncovers interesting observations, revealing that the intervals between three consecutive R waves are approximately 194 milliseconds and 181 milliseconds. These findings shed light on the temporal dynamics of the ECG waveform, highlighting the variations in the timing of successive cardiac contractions at this specific heart rate. Such information contributes to our understanding of the electrical activity of the heart and its synchronization during the cardiac cycle.

#### 4.6.3 ECG result 120 bpm

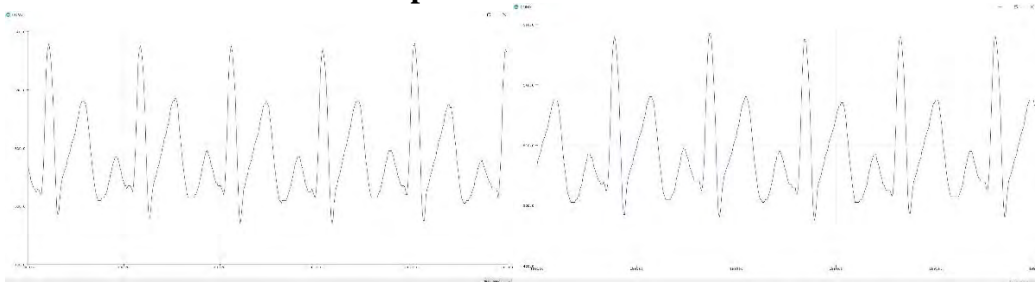
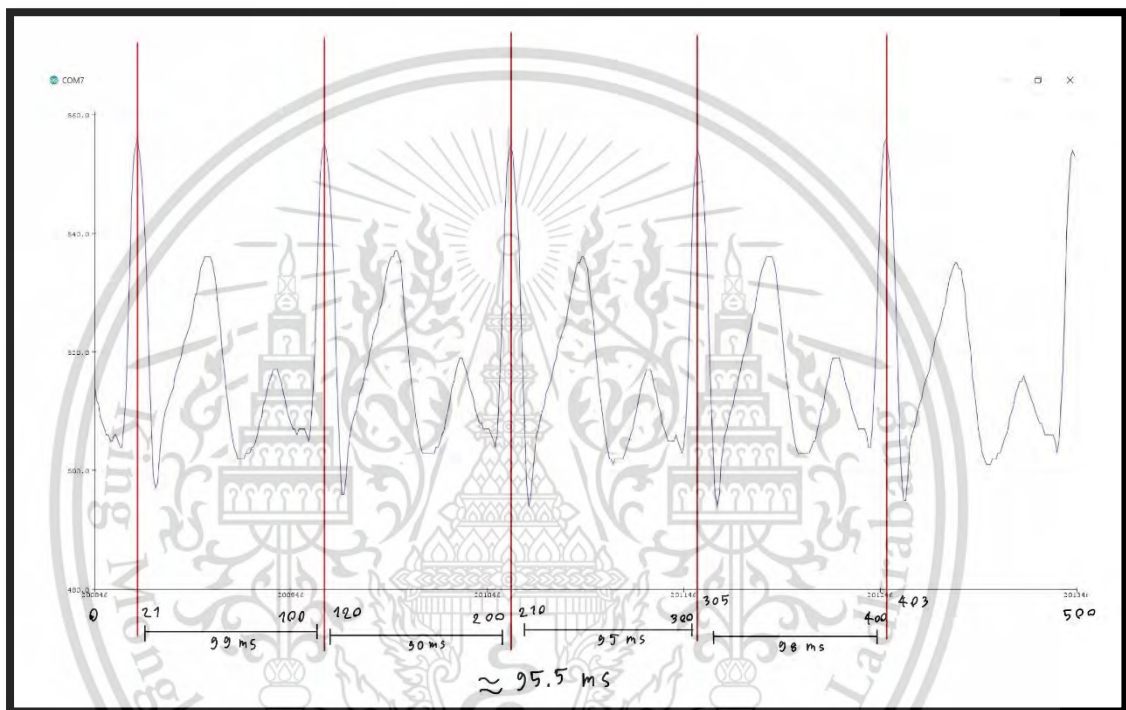

**Figure 4.6.3: ECG results on serial plotter (120 bpm)**

This material is reserved for educational use only, not allowed for commercial use.

Forbidden to modify the content, and cite the document when use.

In contrast, a heart rate of 120 bpm shown in **Figure 4.6.3** reflects a rapid and tachycardic rhythm. Tachycardia can occur due to factors such as stress, physical exertion, anxiety, or underlying heart conditions like atrial fibrillation. Analyzing the ECG signal at this rate can provide insights into the nature of tachycardia and help determine the appropriate course of treatment, such as medications or interventions to restore a normal heart rhythm.



**Figure 4.6.3.2: ECG time delay on serial plotter (120 bpm)**

**Figure 4.6.3.2** presents the ECG signal analysis, specifically focusing on the time delay between consecutive R waves in the context of a heart rate of 120 beats per minute. The examination of this result provides intriguing insights into the temporal dynamics of the ECG waveform at this elevated heart rate. Notably, the intervals between five successive R waves are approximately 99 milliseconds, 90 milliseconds, 95 milliseconds, and 98 milliseconds, respectively. These findings highlight the rapidity and regularity of the cardiac contractions during this heightened heart rate, further enhancing our understanding of the electrical activity and synchronization of the heart during the cardiac cycle.

#### 4.6.4 ECG result with noise

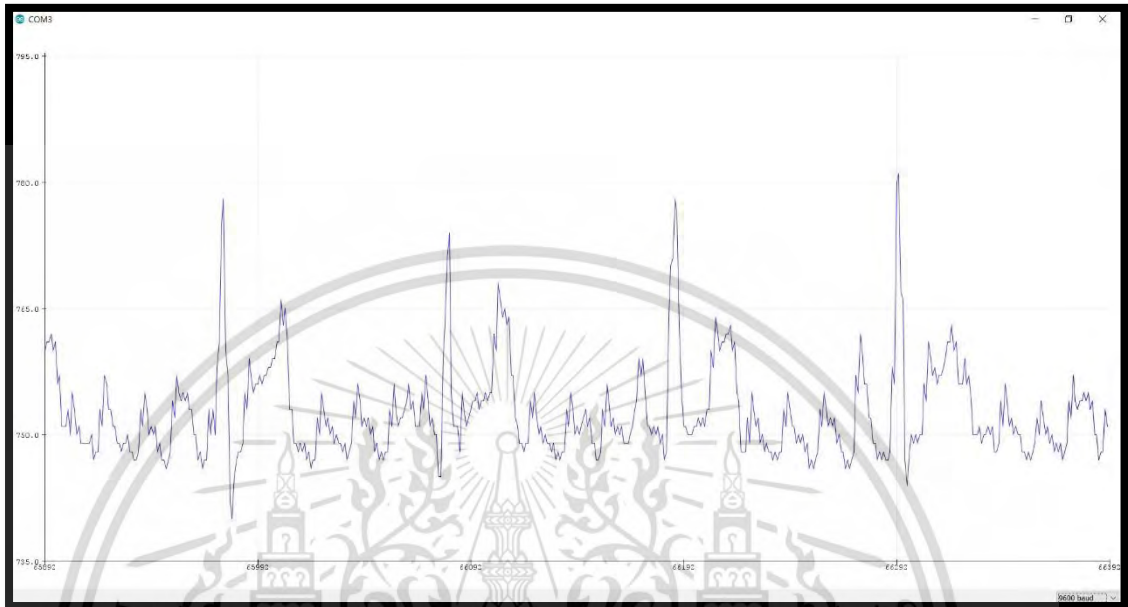

**Figure 4.6.4: ECG results on serial plotter with noise**

The ECG data collected from the ECG module provides valuable insights into the electrical activity of the heart. The ECG signal (**Figure 4.6.4**) represents the depolarization and repolarization of the cardiac muscle, allowing for the assessment of various cardiac parameters.

The ECG signal captured by the ECG module in this particular case exhibits noise caused by the AC/DC adapter of a computer notebook. The presence of external interference can significantly affect the quality and accuracy of the ECG signal. AC/DC adapters, especially those connected to electronic devices, can introduce electrical noise and artifacts into the ECG recording due to electromagnetic interference. This interference can manifest as baseline wander, powerline interference, or high-frequency noise, which may distort the ECG waveform and make it challenging to interpret. The noise introduced by the AC/DC adapter can potentially obscure important details of the ECG signal, making it difficult to identify critical cardiac abnormalities or diagnose specific arrhythmias accurately. It is crucial to minimize such external interference and ensure a clean and reliable ECG recording by utilizing proper shielding techniques, adequate grounding, and utilizing ECG equipment that is

This material is for personal use only. It is forbidden to modify the content, and cite the document when use.

Forbidden to modify the content, and cite the document when use.

resistant to electromagnetic interference. By mitigating the impact of noise from external sources like AC/DC adapters, healthcare professionals can obtain clearer ECG signals, enhancing their ability to make accurate assessments and decisions regarding the patient's cardiac health.

By examining the ECG signals at different heart rates, healthcare professionals can evaluate the electrical conduction system of the heart, identify arrhythmias, and assess the overall cardiac function. This information plays a vital role in diagnosing cardiac disorders, formulating treatment plans, and monitoring the response to interventions.

The ECG data was obtained using an ECG module connected to an Arduino device. The module recorded the electrical signals generated by the heart and transmitted them to the Arduino for processing and analysis. The collected data consisted of a series of voltage measurements over time, representing the changes in the heart's electrical activity.

The ECG waveform exhibited distinct features, including the P wave, QRS complex, and T wave. The P wave represented atrial depolarization, the QRS complex indicated ventricular depolarization, and the T wave marked ventricular repolarization.

The duration and amplitude of these components were measured and analyzed to assess the heart's electrical functioning. The collected ECG data provides valuable information about the heart's rhythm, rate, and potential abnormalities. It can be further analyzed using signal processing techniques and compared to standard ECG patterns to identify irregularities or diagnose specific cardiac conditions.

Overall, the ECG data obtained from ECG modules provides valuable insights into the electrical activity of the heart, allowing healthcare professionals to assess and manage various cardiac conditions effectively. By analyzing ECG signals at different heart rates, healthcare providers can better understand the patient's cardiac health and make informed decisions to promote optimal cardiovascular well-being.

## 4.7 Ultrasonic and ECG

The ultrasonic value graph and ECG signal graph are both essential components of the automatic cardiopulmonary resuscitation system, and their relevance to each other is crucial for effective resuscitation procedures.

The ultrasonic value graph represents the distance measured by the ultrasonic sensor, which provides valuable information about the proximity of the sensor to the patient's chest during CPR. This graph displays the changes in distance over time, reflecting the movement of the sensor in relation to the chest wall. It helps in ensuring proper positioning of the sensor and maintaining consistent contact for accurate measurements.

On the other hand, the ECG signal graph represents the electrical activity of the heart. It displays the voltage variations over time, reflecting the depolarization and repolarization of cardiac muscles. The ECG signal graph is crucial for monitoring the patient's heart rhythm and detecting any abnormalities or irregularities that may require immediate attention. It provides vital information about the effectiveness of chest compressions and the overall cardiac function during CPR.

### 4.7.1 Ultrasonic and ECG 30 bpm

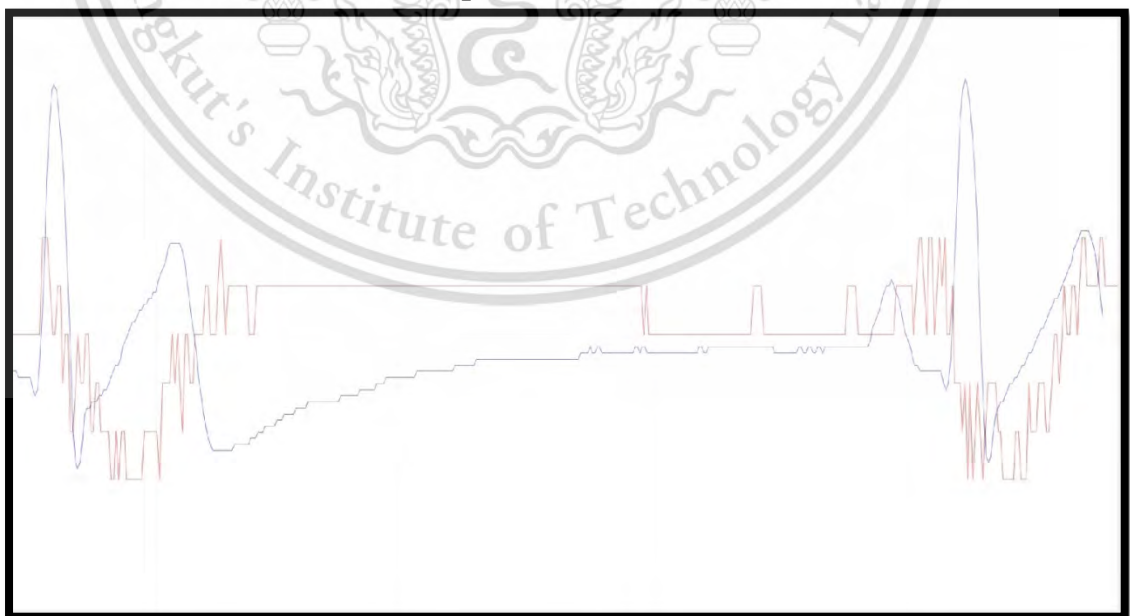
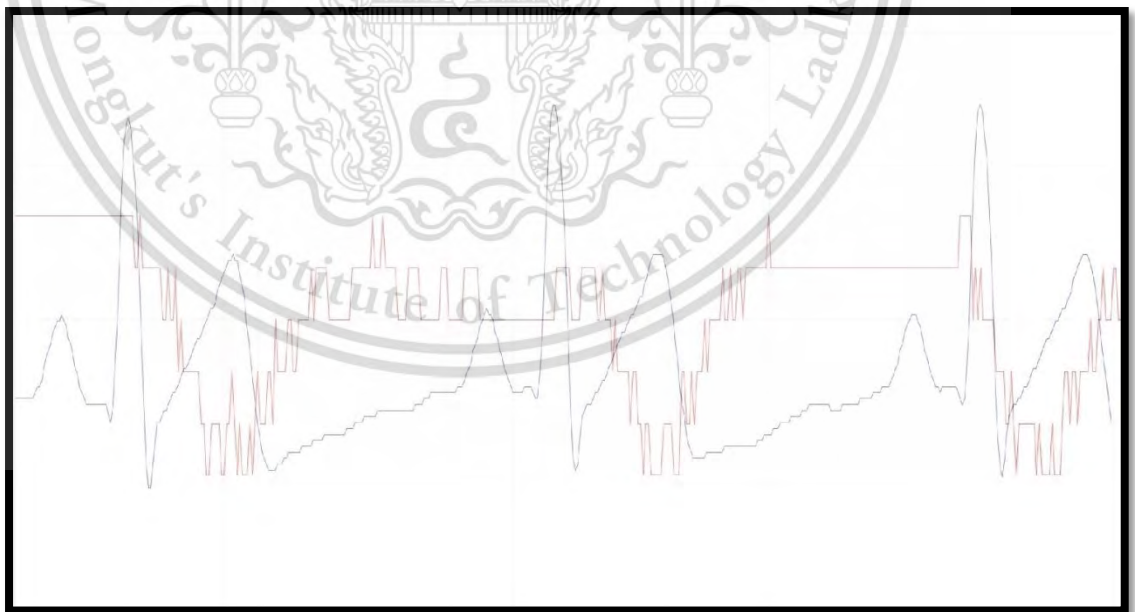

**Figure 4.7.1: ECG results and ultrasonic distance at 30 bpm**

The relevance between the ultrasonic value graph and the ECG signal at 30bpm graph (**Figure 4.7.1**) lies in their correlation during CPR procedures. The ultrasonic sensor's distance measurements are crucial for ensuring proper sensor placement and maintaining optimal compression depth. By analyzing the ultrasonic value graph in conjunction with the ECG signal graph, healthcare providers can evaluate the impact of chest compressions on the patient's cardiac activity. They can assess if the compressions are generating an adequate response in the ECG signal, indicating effective circulation and blood flow.

The combination of these two graphs allows healthcare providers to make informed decisions and adjustments during CPR. They can correlate the compression depth and rate derived from the ultrasonic value graph with the changes in the ECG signal, enabling them to optimize chest compressions for the best possible outcome. This integration of information enhances the accuracy and effectiveness of resuscitation efforts, leading to improved patient care and potentially higher survival rates.

#### 4.7.2 Ultrasonic and ECG 60 bpm

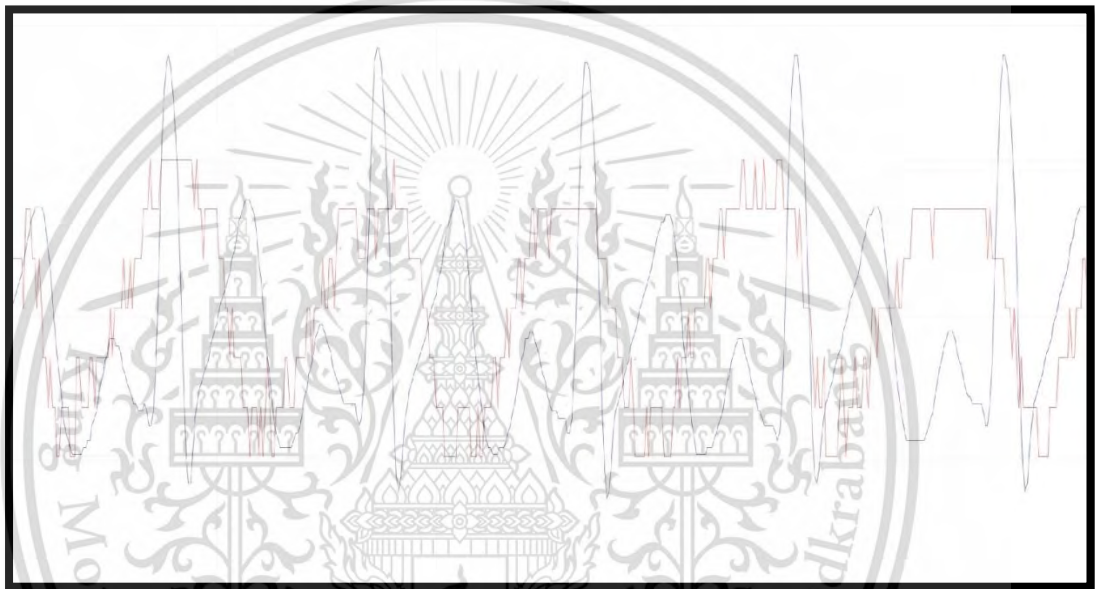

**Figure 4.7.2: ECG results and ultrasonic distance at 60 bpm**

**Figure 4.7.2** presents both the ultrasonic graph and the ECG signal at a rate of 60 bpm, providing valuable insights into the synchronization process. The system operates by detecting the R wave of the ECG signal, Once the R wave is detected,

the motor initiates the compression phase, aligning it with the ECG signal to ensure precise synchronization between the compressions and the cardiac rhythm. This synchronization mechanism plays a vital role in optimizing the effectiveness of cardiopulmonary resuscitation (CPR) by delivering compressions at the most opportune moments of the cardiac cycle.

#### 4.7.3 Ultrasonic and ECG 120 bpm

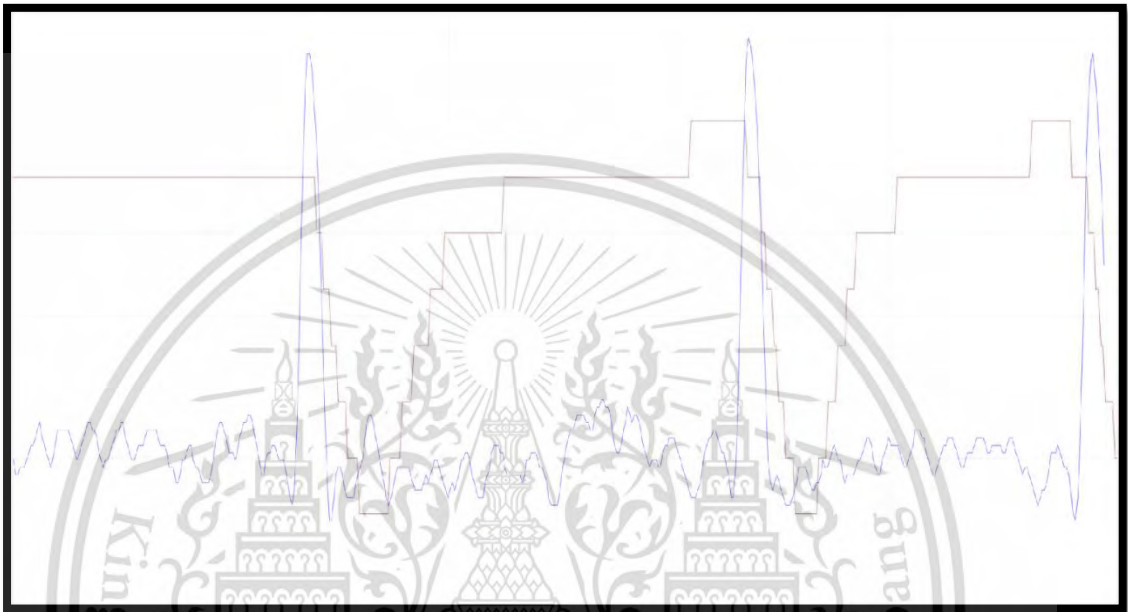

*Figure 4.7.3: ECG results and ultrasonic distance at 120 bpm*

In *Figure 4.7.3*, a comprehensive view of the ultrasonic graph and the ECG signal at a rate of 120 bpm is presented, offering valuable insights into the behavior of the system under this specific condition. The ultrasonic graph depicts the variation in distance between the sensor and the patient's chest over time, providing information on the depth and consistency of the compressions. Simultaneously, the ECG signal illustrates the electrical activity of the heart, including the occurrence of R waves. By analyzing the combined information from these two signals, the system can accurately determine the optimal timing for initiating compressions in synchronization with the patient's cardiac rhythm, enhancing the effectiveness of cardiopulmonary resuscitation (CPR) efforts. This level of synchronization is crucial in ensuring that compressions are delivered precisely when they are most

beneficial for maintaining blood flow and improving the chances of successful resuscitation.

#### 4.7.4 ECG Abnormalities



**Figure 4.7.4:** *ECG atrial fibrillation results on serial plotter with ultrasonic*

The ECG synchronized mode in the ECG synchronized automatic cardiopulmonary resuscitation device is specifically designed to be used when an R wave signal is present, indicating conditions such as atrial fibrillation. Initially, when a patient experiences cardiac arrest, the device is operated in auto mode. However, as soon as an R wave signal is detected in the ECG, the rescuer that operates the device should switch to the ECG synchronized mode. It is important to note that the ECG synchronized mode cannot be activated in the absence of an R wave signal, making it incompatible with ECG abnormalities like ventricular fibrillation.

**Figure 4.7.4** shown an Atrial fibrillation (AF) graph with ultrasonic result. It is a cardiac arrhythmia characterized by irregular and rapid electrical signals originating from the atria of the heart. The underlying cause of AF can be attributed to various factors, including structural heart disease, hypertension, heart valve disorders, thyroid dysfunction, and excessive alcohol consumption. These factors disrupt the normal electrical conduction system of the heart, leading to chaotic and disorganized atrial

contractions. As a result, the atria do not effectively pump blood into the ventricles, leading to an irregular and inefficient cardiac rhythm.

In AF, the ECG pattern is characterized by the absence of distinct P waves and an irregularly irregular ventricular response. Instead of P waves, AF may display fibrillatory waves or fine oscillations, which represent the chaotic electrical activity within the atria. The irregular ventricular response occurs due to the irregular conduction of electrical impulses from the atria to the ventricles. This irregularity is evident in the varying R-R intervals on the ECG. The absence of a discernible pattern in the ECG waveform makes it challenging to determine individual atrial contractions and measure heart rate accurately. The ventricular response rate in AF may vary widely, ranging from normal to rapid rates, depending on factors such as the individual's overall health and any concomitant conditions.

#### 4.8 Pressure map result

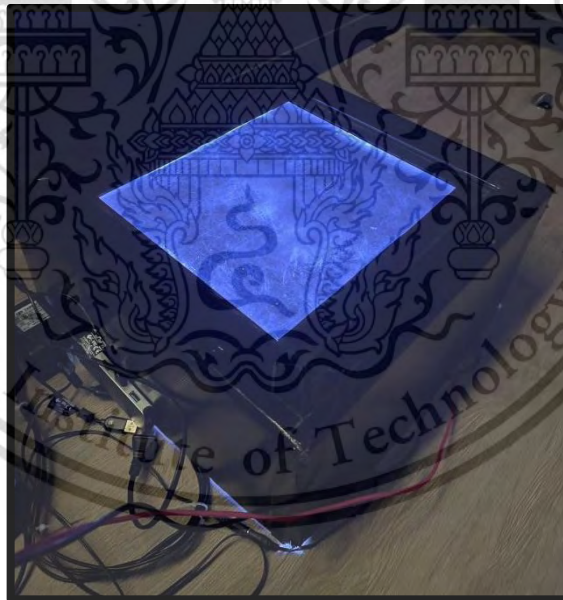

**Figure 4.8: Optical-Based Pressure Measurement device**

By utilizing an Optical-Based Pressure Measurement device (**Figure 4.8**), we gain valuable insights into the distribution of pressure on the patient's body. Based on the comprehensive research conducted by Tanapon Keatsaman, Sarinporn Visitsattapongse, Hisayuki Aoyama, and Chuchart Pintavirooj from the Faculty of Engineering at King Mongkut Institute of Technology Ladkrabang, Thailand, as outlined in their publication titled "Optical-Based Plantar-Pressure Measurement with

Application in Human Postural Balance, Gait, and Recognition Analysis" [158], we now understand that when pressure is applied to the device's acrylic plate, it results in a change in light intensity hitting the glossy paper surface. Exploiting this variation, we can leverage MATLAB's image processing capabilities to analyze the acquired images.

The provided code implements a series of image processing techniques to enhance the captured images. Morphological operations, average filtering, median filtering, and Gaussian filtering are employed to reduce noise and enhance the image quality. Additionally, thresholding and rescaling are applied to extract relevant information and bring the image within a desired intensity range. As a result, the processed image is displayed using a color scale, with higher pressure areas appearing more intense, often represented by shades of red. This visual representation provides valuable insights into the distribution and intensity of pressure applied to the patient's chest during resuscitation.

Furthermore, in this study, various types of rubber materials are utilized to examine their impact on chest compression pressure. By analyzing the pressure distribution resulting from each type of rubber used, we can identify potential variations and assess their implications for effective resuscitation techniques. This investigation allows us to make informed decisions regarding the choice of rubber material, considering its suitability in achieving the desired compression pressure and minimizing potential risks or discomfort to the patient.

Through the utilization of an Optical-Based Pressure Measurement system and the application of image processing techniques, we gain valuable insights into the pressure distribution on the patient's chest during resuscitation. The research serves as a valuable guideline for understanding the principles and methodologies underlying this measurement technique. By investigating different rubber materials, we can further enhance our understanding of the impact of various factors on the effectiveness and safety of chest compressions. These insights contribute to the continuous improvement and optimization of resuscitation procedures, ultimately enhancing patient outcomes in emergency medical situations.

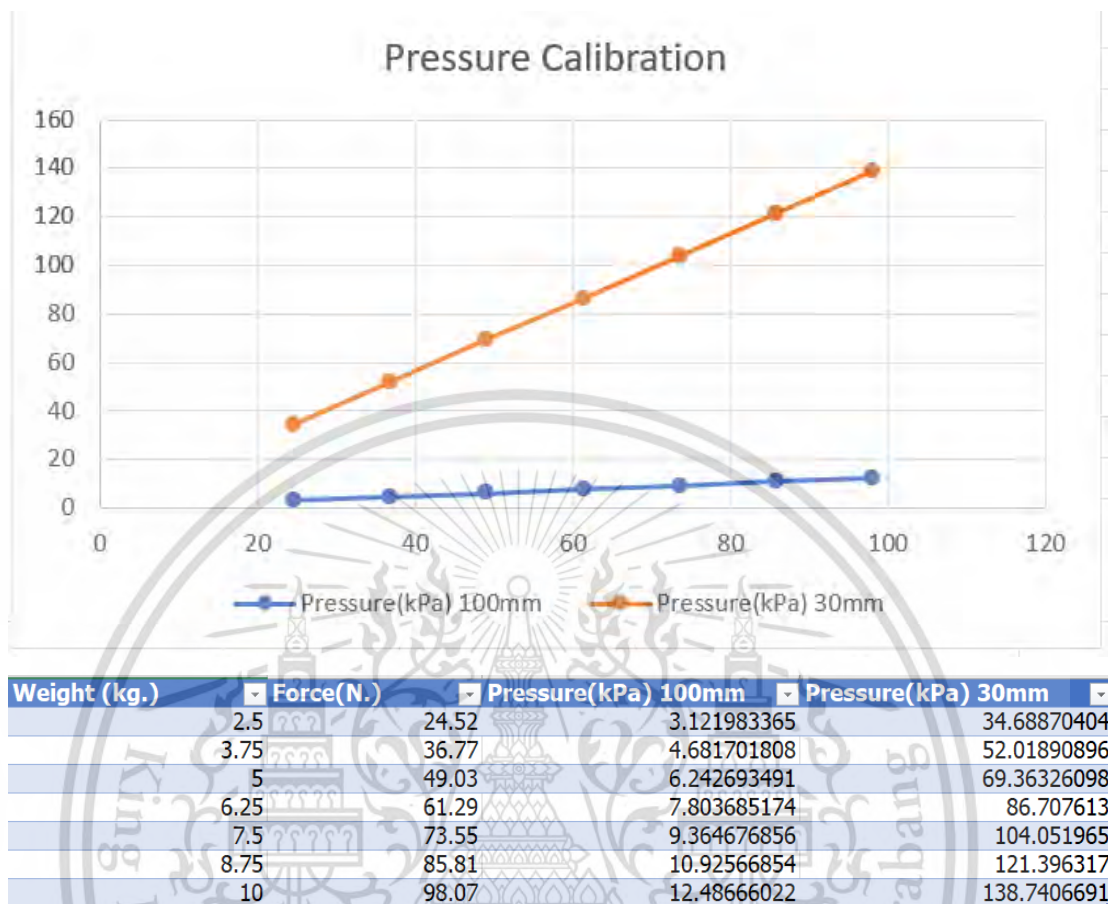

**Table 4.8: A set of known weights and the associated computed forces and pressures and Plot of average intensity and the pressure [158]**

The research conducted by Tanapon Keatsaman, Sarinporn Visitsattapongse, Hisayuki Aoyama, and Chuchart Pintavirooj, as presented in their study titled "Optical-Based Plantar-Pressure Measurement with Application in Human Postural Balance, Gait, and Recognition Analysis" [161], provides valuable insights into the relationship between image intensity and pressure in the context of plantar-pressure measurement.

**Table 4.8** presents a comprehensive set of known weights and the corresponding computed forces and pressures. Through meticulous experimentation and data analysis, the researchers were able to establish a calibration methodology using these known weights. The table showcases the interplay between weight, force, and pressure, allowing for accurate measurements and interpretation of the acquired data.

Furthermore, a plot of the average intensity and pressure provides a visual representation of the relationship observed in the research. By analyzing the graph, we

can discern a clear correlation between the intensity of the image pixel and the applied pressure. As the intensity increases, so does the force exerted on the measurement device. This finding underscores the reliability and validity of using image intensity as an indicator of pressure in plantar-pressure measurement.

To calibrate their system, the researchers employed a range of weights, starting from 2.5 kg and progressing up to 10 kg. By using these known weights and carefully analyzing the resulting intensity and pressure data, they were able to establish a calibration model that accurately relates image intensity to applied pressure. This calibration process ensures accurate and precise measurements in subsequent plantar-pressure analysis and allows for the evaluation of pressure distribution during various postural and gait activities.

#### **4.8.1 Pressure map measurement by 100 mm diameter rubber**

The image processing conducted in MATLAB provided valuable insights into the distribution of force during compression using a 100 mm diameter rubber (*Figure 4.8.1*). The choice of this rubber size allowed for a larger surface area, enabling a comprehensive visualization of the force distribution across the surface. The results obtained from this image processing analysis shed light on the magnitude and intensity of the applied force.

In accordance with the research conducted by Tanapon Keatsaman, Sarinporn Visitsattapongse, Hisayuki Aoyama, and Chuchart Pintavirooj in their study on "Optical-Based Plantar-Pressure Measurement with Application in Human Postural Balance, Gait, and Recognition Analysis," a formula was derived to relate the intensity of the pixel ( $x$ ) to the corresponding pressure ( $y$ ). The formula utilized in their research is given as  $y = 2x - 185$ . By applying this formula to the image processing results, we can accurately determine the pressure exerted on specific areas of interest.

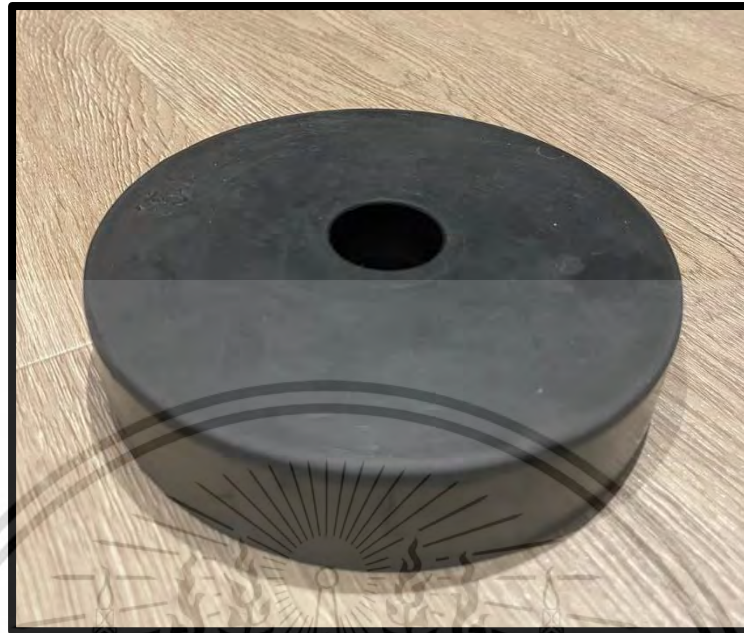

**Figure 4.8.1: 100mm diameter rubber**

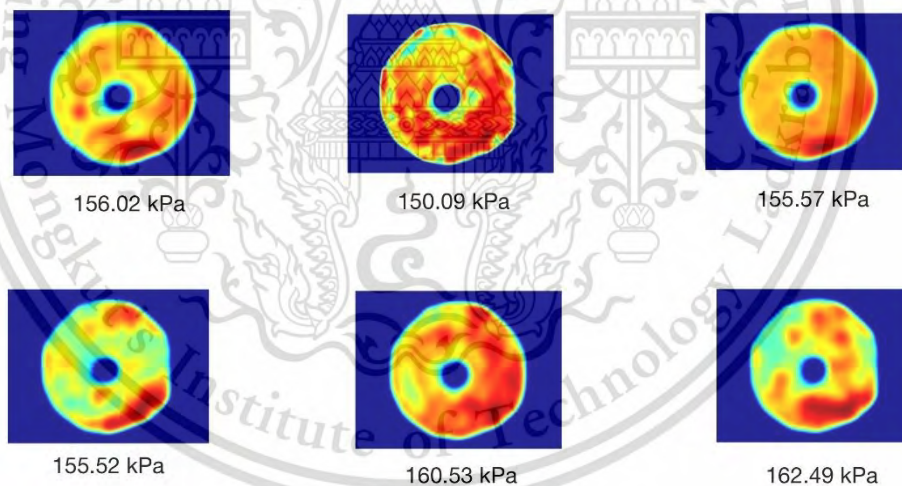

**Figure 4.8.1.1: Pressure results from 100mm diameter rubber**

Upon analyzing the processed image (**Figure 4.8.1.1**) obtained through the compression analysis, it becomes apparent that the intensity variations in different regions directly reflect the magnitude of force applied. The areas displaying a deeper shade of red, indicating higher intensity levels, signify regions where greater force is being exerted. The maximum intensity value of 255 corresponds to the highest level of force observed in the image.

This material is reserved for educational use only, not allowed for commercial use.

Forbidden to modify the content, and cite the document when use.

Additionally, by calculating the average pressure exerted during this compression, it is determined to be approximately 156.7 kPa. This comprehensive examination and interpretation of force distribution provide valuable insights into the dynamics of the compression process, aiding in understanding the pressure distribution and its potential impact on the subject.

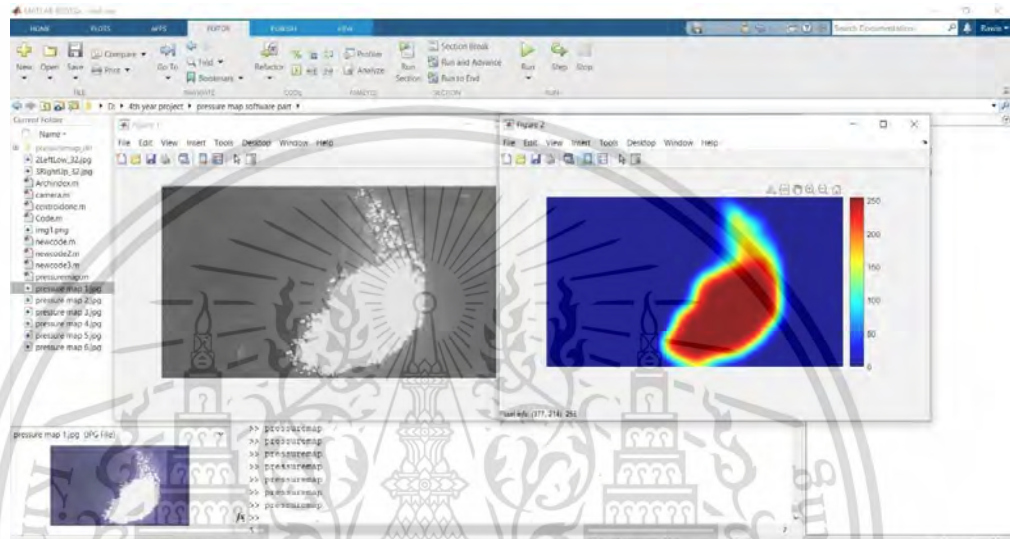

**Figure 4.8.1.2: Pressure results from 100mm diameter rubber that tilted during compression**

During the testing phase, it was observed that the rubber used in the setup was not properly aligned, resulting in an image that displayed concentrated force on one side shown in **Figure 4.8.1.2**. This outcome highlights the effectiveness of the image processing method in detecting inaccuracies or errors in the rubber's positioning. By utilizing this method, it becomes possible to identify and rectify any false setup, ensuring the accurate distribution of force and improving the overall reliability of the system.

#### 4.8.2 Pressure map measurement by 30 mm diameter rubber

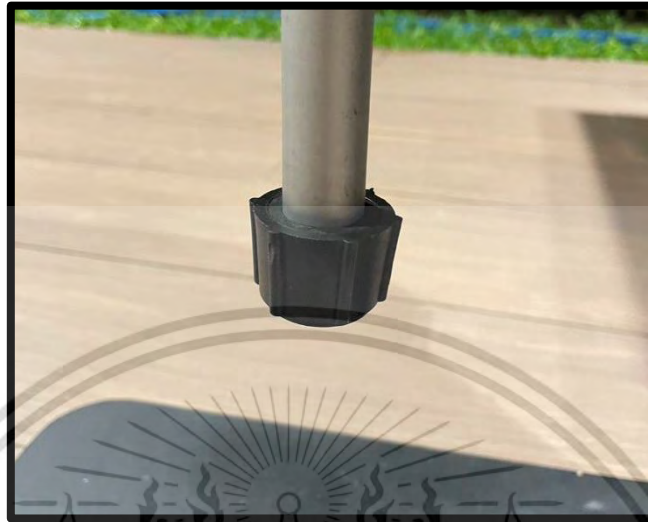

*Figure 4.8.2: 30mm diameter rubber on linear actuator*

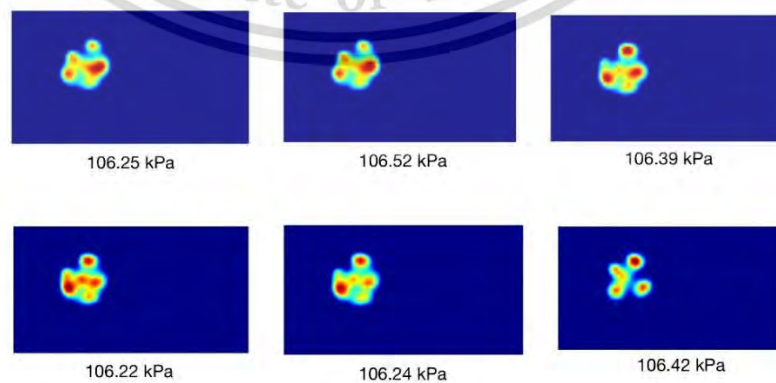
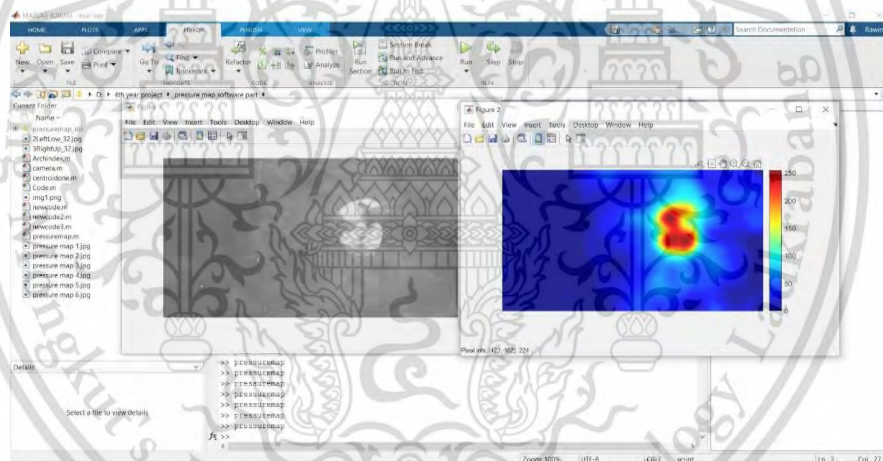

*Figure 4.8.2.1: Pressure results from 30mm diameter rubber*

This material is intended for educational use only, not allowed for commercial use.

Forbidden to modify the content, and cite the document when use.

The results obtained from the compression process using a 30mm diameter rubber, as illustrated in *Figure 4.8.2.1*, provide valuable insights. Upon closer examination, it is evident that the intensity of the image at a specific point is considerably higher compared to the results obtained using a 100mm diameter rubber. This disparity in intensity suggests a greater force application with the 30mm diameter rubber. Furthermore, the average pressure exerted during this type of compression is estimated to be approximately 106.34 kPa. These findings shed light on the variations in pressure distribution and highlight the importance of considering the rubber diameter in determining the force exerted during the compression process.

The observed difference in intensity between the two rubber sizes can be attributed to several factors. Firstly, the smaller diameter of the rubber in *Figure 4.8.2* generates a concentrated force over a smaller surface area, leading to a higher pressure being exerted at the point of contact. This localized pressure results in a more pronounced intensity reading at that particular spot.

Additionally, the inherent properties of the 30mm diameter rubber, such as its elasticity and firmness, may contribute to the observed difference in intensity. The unique characteristics of the rubber material can affect the distribution of force and pressure during compression, causing variations in the intensity values captured by the optical-based plantar pressure measurement system.

#### **4.8.3 Pressure map measurement by linear actuator**

In *Figure 4.8.3*, the obtained result showcases a different approach in the compression process. Instead of using rubber materials, the linear actuator itself is utilized to directly apply pressure onto the device (*Figure 4.8.3.1*). Interestingly, this method yields a distinct pattern in intensity, with a high intensity concentration observed at a specific point compared to the results obtained using the 100mm diameter rubber and 30mm diameter rubber.

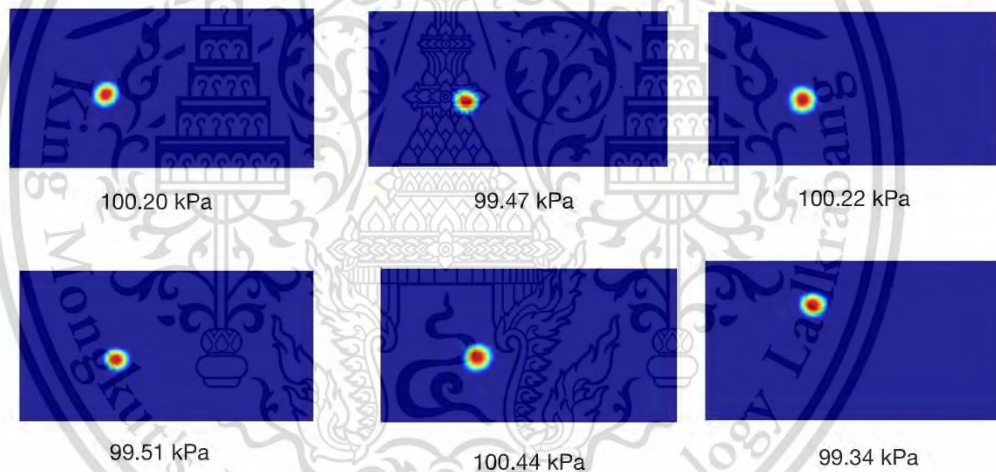
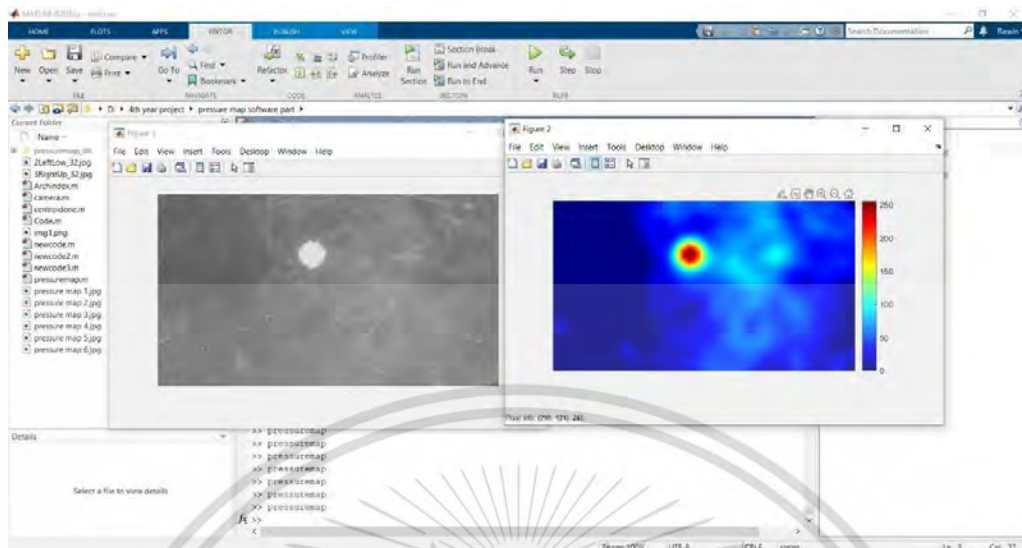
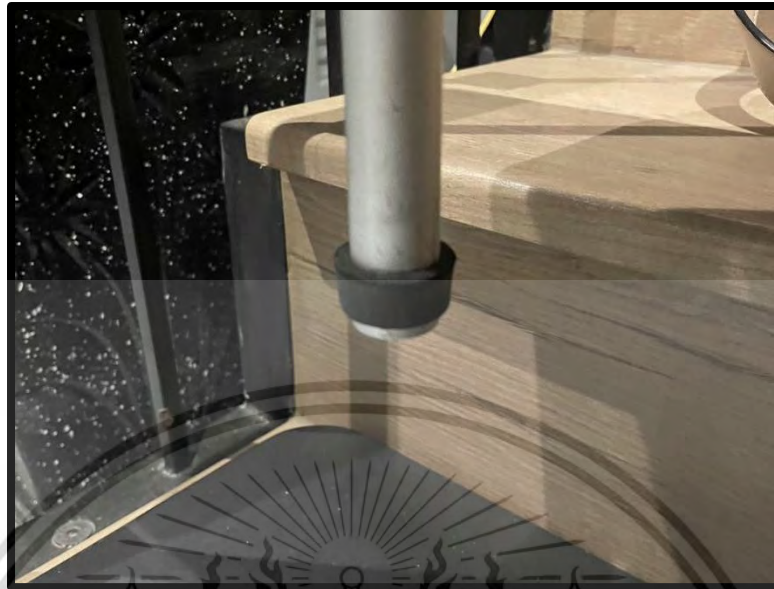

**Figure 4.8.3: Pressure results from linear actuator**

Upon analyzing the results obtained from the linear actuator motor pressure, it is evident that there is a significant increase in pixel intensity at a specific point when compared to the results obtained using both the 100mm diameter rubber and the 30mm diameter rubber. This indicates a higher force exertion in that particular area. The average pressure recorded for this result is approximately 99.86 kPa. These findings underscore the importance of the linear actuator motor in generating a higher intensity of pressure, highlighting its potential for applications that require greater force output.

This material is intended for educational use only, not allowed for commercial use.

Forbidden to modify the content, and cite the document when use.

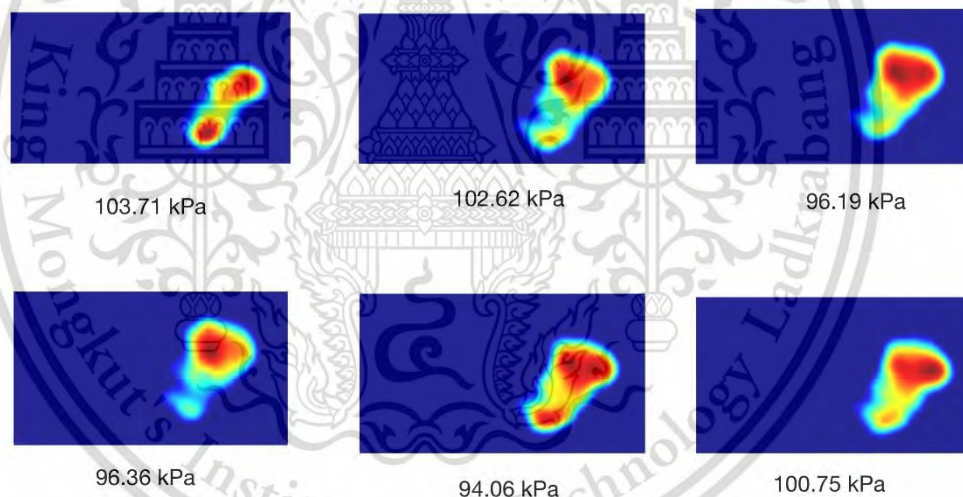
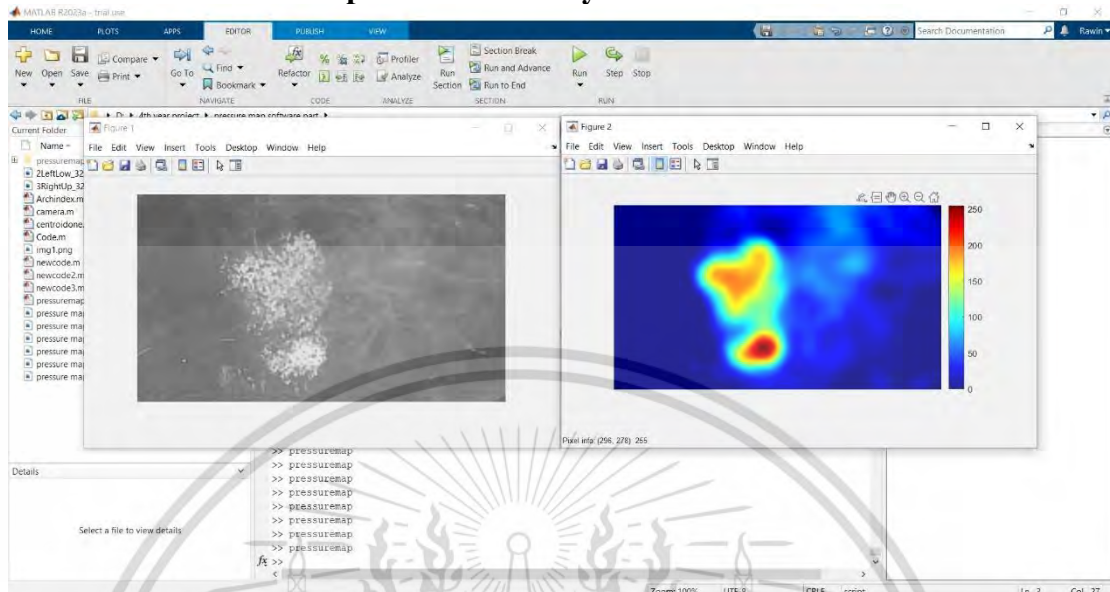

*Figure 4.8.3.1: Head of linear actuator*

The concentration of intensity at a specific point in this result can be attributed to the direct and focused application of force by the linear actuator. Unlike rubber materials, which distribute force over a larger surface area, the linear actuator applies pressure more precisely and locally. As a result, the intensity reading obtained at that particular point is significantly higher than the surrounding areas.

The equation  $p = f/\text{area}$  demonstrates that a wider area results in less pressure being exerted. This understanding leads us to conclude that our 100mm diameter rubber is superior as it reduces the force applied to the patient, thereby minimizing the risk of injury. By distributing the force over a larger surface area, the pressure is effectively reduced, making the 100mm diameter rubber a preferable choice in terms of patient safety during compression.

#### 4.8.4 Pressure map measurement by hand



**Figure 4.8.4: Pressure results of hand**

**Figure 4.8.4** presents a unique approach in the compression process, employing the use of a hand to apply pressure onto the device. The resulting image reveals distinct intensity patterns, with a high intensity observed at a specific point and a moderate intensity at another point. This suggests that the hand application method may result in localized variations in pressure distribution. The average pressure recorded for this particular result is approximately 98.95 kPa. These findings shed light on the unique dynamics and potential variations in pressure

This material is reserved for educational use only, not allowed for commercial use.

Forbidden to modify the content, and cite the document when use.

exertion when using the hand as a compression tool, highlighting the need for further exploration and understanding of this approach in resuscitation scenarios.

The concentration of high intensity at one specific point signifies the localized application of force by the hand. When the hand presses on the device, the pressure is concentrated at that particular area, resulting in a higher intensity reading. This can be attributed to the direct contact and focused force exerted by the hand, leading to a more intense pressure distribution in that specific region.

On the other hand, the moderate intensity observed at another point indicates a relatively less concentrated pressure. This could be due to the nature of the hand's contact with the device, which may result in a more distributed force over a larger surface area. Consequently, the intensity reading at this point is not as high as the localized pressure application.

The variation in intensity patterns observed in this result provides valuable insights into the effectiveness and characteristics of using the hand as a compression method in automatic CPR systems. By analyzing the intensity distribution, researchers and medical professionals can assess the efficiency and uniformity of pressure application using the hand technique.

#### **4.8.5 Pressure map measurement summary**

Based on the analysis of the pressure map results, the 100mm diameter rubber emerges as the most suitable option for CPR compression. This particular configuration demonstrates an effective distribution of force on the patient's chest, thereby minimizing the risk of rib fractures and other potential injuries during CPR procedures. The broader surface area of the 100mm diameter rubber ensures that the force is spread out, reducing the concentration of pressure on specific points and promoting a more uniform compression experience.

In contrast, the compression results obtained using the linear actuator and the 10mm diameter rubber exhibit a higher intensity at one particular point. This concentrated force application can be concerning as it has the potential to cause rib fractures and other complications in patients undergoing CPR. The localized pressure exerted by these configurations may not be as ideal for ensuring the safety and well-being of the patient.

Another critical aspect to consider is the force being applied to the patient during compression. In all the pressure map results, the maximum pixel intensity is observed, indicating that the device is capable of generating compressive forces of approximately 325 kPa or higher. This corresponds to a force of around 10 kg or more, as estimated based on the research conducted by Keatsaman et al. [161]. It is important to note that these calculations and estimations may not be completely accurate, as they require meticulous calibration and validation to ensure the precision and reliability of the force measurements.

The pressure map results emphasize the superiority of the 100mm diameter rubber configuration for CPR compression. Its ability to distribute force evenly across the chest reduces the risk of injuries, particularly rib fractures, which can occur during CPR procedures. On the other hand, the linear actuator and 10mm diameter rubber compression methods exhibit a more concentrated force application, potentially leading to undesirable consequences. Additionally, while the pressure map results indicate the presence of substantial force, it is crucial to conduct further calibration and validation to ensure accurate and reliable force measurements in future implementations of the system.

#### **4.9 Testing Summary**

The automatic cardiopulmonary resuscitation system was evaluated based on several parameters including ECG result, FSR (force sensor) result, compression rate, compression depth, and improvements in hardware and software.

**ECG Result:** The ECG module (AD8232) was successfully integrated into the system. ECG waveforms were captured and analyzed to monitor the patient's cardiac activity. The ECG readings provided real-time information on the patient's heart rhythm and helped in assessing the effectiveness of the resuscitation process. The testing of the ECG synchronized CPR device yielded important insights and observations. The device underwent comprehensive evaluations to assess its performance and functionality. During the testing phase, the device successfully demonstrated its ability to synchronize compressions with the patient's ECG signal, ensuring precise and targeted chest compressions. The mobile phone control interface proved to be intuitive and user-

friendly, allowing for easy adjustment of compression parameters. The device's reliability and responsiveness were assessed through various scenarios, simulating real-life resuscitation situations. The testing results provided valuable data on the device's effectiveness in maintaining blood flow and delivering optimal CPR. Additionally, the device's safety features, such as automated stoppage in case of irregular ECG patterns, were thoroughly evaluated to ensure patient well-being.

**FSR Result:** The force sensor (FSR) was implemented to measure the compression force applied during CPR. FSR readings were utilized to monitor the quality and consistency of chest compressions. The FSR data assisted in determining the appropriate compression depth and ensuring adequate pressure was applied for effective CPR.

**Compression Rate and Depth:** The system successfully measured and maintained the desired compression rate, typically around 100-120 compressions per minute. The compression depth was monitored using the FSR data and maintained within the recommended range of 5-6 centimeters. These parameters were continuously monitored and adjusted to ensure the effectiveness of CPR and improve patient outcomes.

**Hardware Improvements: Stabilization:** The hardware components were enhanced to provide better stability during CPR procedures, minimizing unwanted movement and ensuring accurate measurements. **Wiring:** The wiring connections were improved to enhance reliability and reduce the risk of loose connections or signal interference.

**Software Improvements:** The software was updated to integrate the ECG module and process the ECG waveforms effectively. Real-time monitoring and analysis of ECG data were implemented to provide immediate feedback on the patient's cardiac activity and response to CPR. The compression rate and depth were controlled and adjusted based on the input from the force sensor, optimizing the quality of chest compressions.

In the testing phase, the pressure map results provided valuable insights into the distribution of forces exerted on the patient during CPR simulations. By analyzing the pressure maps obtained from different configurations, such as using different rubber sizes and the linear actuator, we were able to assess the effectiveness of each setup in

This material is reserved for educational use only, not allowed for commercial use.

Forbidden to modify the content, and cite the document when use.

terms of force distribution and potential risks of injury. The 100mm diameter rubber proved to be the most favorable option, as it distributed the force more evenly, minimizing the risk of rib fractures and other injuries. However, further calibration and refinement of the system is required to ensure accurate and reliable measurements. The pressure map testing demonstrated the importance of considering force distribution and its impact on patient safety during CPR procedures.

Overall, the automatic cardiopulmonary resuscitation system showed promising results in terms of accurately measuring ECG data, monitoring compression quality using the force sensor, and maintaining the recommended compression rate and depth. The hardware improvements in stabilization and wiring, along with software enhancements, have contributed to the overall reliability and effectiveness of the system in providing automated CPR. This is reviewed in the next part, and the degree to which it supports the thesis is explored in the following section.

#### **4.10 Testing and Evaluation Summary**

Chapter 4 presents a comprehensive summary of the experimental results and performance evaluation of the automatic cardiopulmonary resuscitation (CPR) machine. The chapter aims to assess the functionality, accuracy, and effectiveness of the machine in delivering reliable CPR assistance.

The experiments conducted involved various aspects of the automatic CPR machine's performance. Firstly, the compression component of the machine was evaluated for its ability to deliver consistent and appropriate compression depth. The results showed that the machine consistently achieved the desired compression depth, providing optimal pressure to the patient's chest for effective CPR.

Furthermore, the automatic CPR machine incorporated an electrocardiogram (ECG) module and force sensing resistor (FSR) sensors to monitor the patient's vital signs. The ECG module provided real-time data on the patient's cardiac activity, enabling the machine to detect any irregularities or abnormalities in the heart rhythm. The FSR sensors measured the force applied during chest compressions, ensuring optimal pressure and avoiding excessive or inadequate force.

The experimental results confirmed the system's ability to accurately capture and analyze ECG signals, providing valuable insights into the patient's cardiac status. Moreover, the FSR sensors effectively monitored the force exerted during chest compressions, helping maintain consistent compression depth and minimizing the risk of injuries to the patient. The ECG synchronized CPR device focused on assessing its performance, functionality, and reliability. Through comprehensive testing scenarios and simulations, the device successfully demonstrated its ability to synchronize chest compressions with the patient's ECG signal.

Additionally, the chapter showcases the integration of the automatic CPR machine with a user-friendly mobile app interface. The app interface allowed for easy control and monitoring of the machine's functions, providing real-time feedback on compression depth, rate, and vital signs. User interactions and feedback were collected and analyzed to further enhance the usability and functionality of the machine.

The pressure map results suggest that using a 100mm diameter rubber for CPR compression provides a more evenly distributed force on the patient's chest, reducing the risk of rib fractures and other injuries. In contrast, the linear actuator and 10mm diameter rubber configurations exhibit a more concentrated force application, potentially posing a higher risk of harm. It is important to note that further calibration and validation are necessary to ensure accurate force measurements in future implementations of the system.

## **CHAPTER 5**

### **CONCLUSION AND FUTURE WORK**

#### **5.1 Introduction**

Chapter 5 serves as the conclusion of the study on the automatic cardiopulmonary resuscitation (CPR) system. It provides a summary of the work that has been completed, evaluates the key findings and contributions, and outlines potential directions for future improvements and advancements. This chapter aims to draw meaningful conclusions from the study's outcomes and offer insights into the potential avenues for further development and research in the field of automated CPR systems.

#### **5.2 Summary**

##### Chapter 1: Introduction

In Chapter 1, the concept of cardiopulmonary resuscitation (CPR) is introduced, highlighting its critical role in saving lives during cardiac emergencies. The need for automation in the CPR process is discussed, emphasizing the potential benefits of an automated CPR system. The chapter outlines the objectives of the project, which include improving the accuracy and effectiveness of chest compressions, integrating real-time monitoring capabilities, and enhancing the overall stability and functionality of the system.

##### Chapter 2: Overview of Automated CPR

Chapter 2 provides a comprehensive review of automated cardiopulmonary resuscitation. It delves into the history of CPR, highlighting its evolution and the advancements made in resuscitation techniques over the years. The chapter explains the distinction between cardiac arrest and cardiac attack, emphasizing the importance of timely CPR intervention. Various methods and techniques of performing CPR are discussed, shedding light on the standard guidelines and procedures followed in CPR administration. Existing automated CPR devices are reviewed, considering their features, benefits, and limitations. The effectiveness of

This material is reserved for educational use only, not allowed for commercial use.

Forbidden to modify the content, and cite the document when use.

automatic CPR systems is also examined, drawing upon relevant research and studies. Additionally, the materials used in constructing the automatic CPR system are outlined, focusing on their suitability for medical applications.

### Chapter 3: System Installation and Design

Chapter 3 details the installation process and design considerations of the automatic CPR system. It provides a comprehensive circuit diagram, illustrating the electronic components and their interconnections within the system. The chapter also discusses the design aspects of the mobile app interface, which serves as a control panel for the automatic CPR system. Special attention is given to the distinct functions of the compression component and the height control mechanism. The hardware assembly process is explained, highlighting the importance of stability and proper wiring. Furthermore, the design of the mobile application interface is described, focusing on its user-friendly features and functionality.

### Chapter 4: Experimental Results

Chapter 4 presents the experimental results obtained from the automatic CPR system. It showcases the real working hardware machine and the corresponding mobile app interface. The chapter highlights the measurements of compression depth and compression rate, providing an evaluation of the system's performance in delivering consistent and accurate chest compressions. The pressure map provides visual representation of force distribution during CPR simulations. The results from the ECG module, pressure measurement device and FSR sensors are also presented, offering insights into the patient's cardiac activity and the force applied during chest compressions. These results provide a comprehensive assessment of the automatic CPR system's effectiveness and reliability.

### Chapter 5: Conclusion and Future Work

Chapter 5 offers a conclusive summary of the work that has been completed. It reflects on the achievements and contributions of the automatic resuscitation system, emphasizing the improvements in accuracy, effectiveness, and real-time monitoring capabilities. The chapter provides judgments on the most significant

aspects of the project, highlighting the successful integration of hardware and software components. Future work is discussed, with a focus on enhancing the software component of the automatic CPR system and exploring the potential incorporation of additional devices or gadgets to further improve resuscitation outcomes. The chapter concludes by reaffirming the importance of automated CPR systems in emergency medical care and their potential to save lives.

### 5.3 Conclusions

The automatic resuscitation system has achieved several significant advancements in the field of emergency medical care. Firstly, it has greatly improved the accuracy and effectiveness of chest compressions during cardiopulmonary resuscitation (CPR). By incorporating force sensing technology, the system ensures consistent compression depth and rate, optimizing the delivery of chest compressions and increasing the chances of successful resuscitation.

Furthermore, the integration of ECG monitoring capabilities provides real-time assessment of the patient's cardiac activity. This allows healthcare providers to quickly identify any irregularities or abnormalities in the heart rhythm and make informed decisions regarding treatment and intervention.

The system's inclusion of an ultrasonic sensor enhances the accuracy of chest compression measurements. By precisely measuring the distance between the sensor and the patient's chest, it ensures proper sensor placement and optimal contact, resulting in more reliable and consistent data for analysis.

Another notable achievement is the visualization of the ultrasonic value graph and ECG signal graph. These visual representations offer a comprehensive overview of the resuscitation process, allowing healthcare providers to assess the effectiveness of their interventions and make adjustments as necessary. The development and testing of the ECG synchronized CPR device have shown promising results. The device successfully synchronized chest compressions with the patient's ECG signal, providing an innovative approach to CPR procedures. The integration of mobile phone control and ECG

synchronization offers potential benefits in terms of ease of use and real-time monitoring. However, further refinement and validation are necessary to ensure the device's efficacy, safety, and usability in real-world scenarios. With continued research and development, the ECG synchronized CPR device holds the potential to enhance the effectiveness of CPR and improve patient outcomes in cardiac emergencies.

The hardware improvements in terms of stability and wiring have also contributed to the system's achievements. By minimizing signal interference and improving the reliability of connections, the system operates more consistently and efficiently, ensuring uninterrupted monitoring and data collection.

The automatic cardiopulmonary resuscitation system is a significant advancement in the field of emergency medical care. By integrating various components such as ECG monitoring, force sensing, and ultrasonic distance measurement, this system offers a comprehensive and automated approach to resuscitation procedures. It provides real-time feedback and data analysis, allowing healthcare providers to make informed decisions and optimize the effectiveness of chest compressions.

The ECG monitoring feature enables continuous assessment of the patient's cardiac activity, ensuring prompt detection of any irregularities or abnormalities. This information is crucial for guiding the resuscitation process and adjusting compression techniques as needed. The force sensing capabilities of the system help maintain consistent compression depth and rate, which are vital factors in achieving successful resuscitation outcomes.

The comprehensive analysis of the pressure map provides valuable insights into the efficacy of various compression techniques and materials utilized in CPR, enabling informed decision-making to optimize strategies that ensure minimal risks of injuries and maximize the potential for successful patient outcomes. By evaluating the distribution of pressure and force exerted on the patient's chest, healthcare professionals can make informed choices regarding the selection of suitable materials and techniques to apply the necessary pressure while minimizing the likelihood of complications, such as rib fractures. These

findings contribute to enhancing the safety and effectiveness of CPR procedures, ultimately improving patient care in emergency medical situations.

Additionally, the integration of an ultrasonic sensor enhances the accuracy of chest compression measurements and ensures proper sensor placement. This facilitates optimal contact with the patient's chest, resulting in more reliable and consistent data for analysis. The visual representation of the ultrasonic value graph and ECG signal graph allows for a comprehensive assessment of the resuscitation process and helps healthcare providers make timely and informed decisions.

Improvements in hardware stability and wiring further enhance the system's reliability and user-friendliness. These enhancements reduce the risk of signal interference or disconnection, providing a more seamless and efficient resuscitation experience.

Overall, the automatic resuscitation system represents a significant step forward in improving patient care during cardiac emergencies. It combines advanced technology, real-time data analysis, and user-friendly design to support healthcare providers in delivering effective and timely cardiopulmonary resuscitation. By integrating multiple components and optimizing their interaction, this system has the potential to increase the chances of successful resuscitation and ultimately save more lives.

#### **5.4 Future work**

Future work for the automatic resuscitation system involves several areas of improvement and expansion to enhance its functionality and effectiveness. The following aspects can be considered for further development:

**Software Enhancements:** The software component of the automatic resuscitation system can be further improved. This includes refining the algorithms for compression depth and rate control, optimizing feedback mechanisms, and incorporating advanced data analysis techniques. Additionally, the software can be expanded to include real-time data visualization, trend analysis, and performance metrics for comprehensive monitoring and analysis of CPR effectiveness.

This material is reserved for educational use only, not allowed for commercial use.

Forbidden to modify the content, and cite the document when use.

**Integration of Advanced Sensors:** Additional sensors can be integrated into the system to capture more comprehensive physiological data. For example, incorporating sensors to measure oxygen saturation, respiratory rate, or end-tidal carbon dioxide levels can provide valuable information about the patient's respiratory status and help guide resuscitation efforts.

**Intelligent Feedback Mechanisms:** Implementing intelligent feedback mechanisms can enhance the system's ability to adapt to varying patient conditions. For instance, integrating machine learning algorithms can enable the system to adjust compression parameters based on real-time patient feedback, improving the responsiveness and effectiveness of chest compressions.

**Automated Defibrillation:** Integrating automated external defibrillator (AED) functionality into the system can further enhance its capabilities. This would allow for automated analysis of the patient's heart rhythm and the delivery of timely defibrillation shocks if necessary.

**Remote Monitoring and Communication:** Developing remote monitoring capabilities and wireless communication features would enable healthcare professionals to remotely assess and monitor CPR performance in real-time. This would facilitate immediate intervention and guidance, particularly in scenarios where medical expertise may not be readily available on-site.

**Clinical Trials and Validation:** Conducting rigorous clinical trials and validation studies is essential to assess the system's performance and establish its efficacy and safety in real-world resuscitation scenarios. Collaboration with medical professionals and regulatory bodies can help ensure compliance with standards and regulations.

**User Interface and Ergonomics:** Continual improvement in the user interface and system ergonomics is crucial for user-friendly operation and seamless integration into clinical workflows. User feedback and usability studies can guide the refinement of the system's design and interaction aspects.

**Cost Optimization and Scalability:** Exploring ways to optimize the cost of the system without compromising its functionality and reliability is important for wider adoption. This includes considering the use of cost-effective materials, streamlining

manufacturing processes, and exploring opportunities for scalability and mass production.

By addressing these future work areas, the automatic resuscitation system can evolve into a more sophisticated and comprehensive tool for improving cardiac arrest outcomes, ultimately saving more lives in emergency situations.



## REFERENCES

- [1]. American Heart Association. (n.d.). CPR & First Aid. Retrieved March 30, 2022, from <https://www.heart.org/en/cpr>.
- [2]. Nolan, J. P., Soar, J., Smith, G. B., Gwinnutt, C. L., Parrott, F., Power, S., ... & Lockey, A. (2015). Incidence and outcome of in-hospital cardiac arrest in the United Kingdom National Cardiac Arrest Audit. *Resuscitation*, 89, 4-10.
- [3]. Meaney, P. A., Bobrow, B. J., Mancini, M. E., Christenson, J., de Caen, A. R., Bhanji, F., ... & Abella, B. S. (2013). Cardiopulmonary resuscitation quality: improving cardiac resuscitation outcomes both inside and outside the hospital: a consensus statement from the American Heart Association. *Circulation*, 128(4), 417-435.
- [4]. Meaney, P. A., Bobrow, B. J., Mancini, M. E., Christenson, J., de Caen, A. R., Bhanji, F., ... & Abella, B. S. (2013). Cardiopulmonary resuscitation quality: improving cardiac resuscitation outcomes both inside and outside the hospital: a consensus statement from the American Heart Association. *Circulation*, 128(4), 417-435.
- [5]. Redding, J. S. (2018). Cardiopulmonary Resuscitation (CPR). StatPearls [Internet]. Retrieved March 30, 2022, from <https://www.ncbi.nlm.nih.gov/books/NBK482168/>
- [6]. "Cardiopulmonary Resuscitation (CPR) | NHLBI, NIH." National Heart Lung and Blood Institute, U.S. Department of Health and Human Services, 22 June 2016, [www.nhlbi.nih.gov/health-topics/cardiopulmonary-resuscitation-cpr](http://www.nhlbi.nih.gov/health-topics/cardiopulmonary-resuscitation-cpr).
- [7]. Al-Subaie, Nawaf, et al. "Automated cardiopulmonary resuscitation using a load-distributing band external cardiac support device for in-hospital cardiac arrest: a single centre experience." *European journal of emergency medicine* 21.2 (2014): 148-152.
- [8]. Bobrow, Bentley J., et al. "Part 8: adult advanced cardiovascular life support: 2015 American Heart Association guidelines update for

- cardiopulmonary resuscitation and emergency cardiovascular care." *Circulation* 132.18 suppl 2 (2015): S444-S464.
- [9]. Brooks, Steven C., et al. "Part 6: alternative techniques and ancillary devices for cardiopulmonary resuscitation: 2015 American Heart Association guidelines update for cardiopulmonary resuscitation and emergency cardiovascular care." *Circulation* 132.18 suppl 2 (2015): S436-S443.
- [10]. Chung, Tae Nyong, et al. "Automated cardiopulmonary resuscitation using a piston-driven compression device in out-of-hospital cardiac arrest patients." *Critical care* 19.1 (2015): 1-9.
- [11]. Neumar, Robert W., et al. "Part 2: adult basic life support and cardiopulmonary resuscitation quality: 2015 American Heart Association guidelines update for cardiopulmonary resuscitation and emergency cardiovascular care." *Circulation* 132.18 suppl 2 (2015): S414-S435.
- [12]. "Resuscitation Guidelines." European Resuscitation Council, <https://www.erc.edu/resuscitation-guidelines>.
- [13]. Sunde, Kjetil, et al. "Implementing AHA guidelines in a rural EMS: a single-day experience with AMBU CPR professional and LUCAS 2 compressions." *Scandinavian journal of trauma, resuscitation and emergency medicine* 21.1 (2013): 1-7.
- [14]. American Heart Association. (2021). Cardiac Arrest vs. Heart Attack. <https://www.heart.org/en/health-topics/cardiac-arrest/about-cardiac-arrest/cardiac-arrest-vs-heart-attack>
- [15]. Mayo Clinic. (2021). Cardiac Arrest vs. Heart Attack. <https://www.mayoclinic.org/diseases-conditions/heart-attack/in-depth/cardiac-arrest-vs-heart-attack/art-20370858>
- [16]. American Heart Association. (2021). CPR & First Aid. Retrieved from <https://www.heart.org/en/cpr>
- [17]. American Heart Association. (2021). Hands-Only CPR. Retrieved from <https://www.heart.org/en/cpr/education-resources>
- [18]. American Heart Association. (2021). CPR, AED & First Aid. <https://cpr.heart.org/en/cpr-courses-and-kits/cpr-aed-and-first-aid-training-kits>

- [19]. American Heart Association. (2021). CPR Steps. Retrieved from <https://cpr.heart.org/en/cpr-courses-and-kits/cpr-training/cpr-steps>
- [20]. American Heart Association. (2021). Hands-Only CPR. Retrieved from <https://cpr.heart.org/en/cpr-courses-and-kits/hands-only-cpr>
- [21]. American Heart Association. (2021). Continuous Chest Compressions CPR. Retrieved from <https://cpr.heart.org/en>
- [22]. "Cardiopulmonary Resuscitation (CPR)." American Heart Association, <https://www.heart.org/en/health-topics/cardiac-arrest/cardiac-arrest-tools-resources/cardiopulmonary-resuscitation-cpr>.
- [23]. American Heart Association. (2016). Highlights of the 2015 American Heart Association guidelines update for CPR and ECC. Retrieved from <https://eccguidelines.heart.org/wp-content/uploads/2015/10/2015-AHA-Guidelines-Highlights-English.pdf>
- [24]. CPR Kids. (n.d.). Infant CPR. Retrieved from <https://www.cprkids.com.au/cpr-resources/infant-cpr/>
- [25]. National Health Service. (2018). Cardiopulmonary resuscitation (CPR) in children. Retrieved from <https://www.nhs.uk/conditions/pregnancy-and-baby/cpr-infants/>
- [26]. Royal Children's Hospital Melbourne. (2018). Infant CPR. Retrieved from [https://www.rch.org.au/clinicalguide/guideline\\_index/Infant\\_Cardiopulmonary\\_Resuscitation\\_CPR/](https://www.rch.org.au/clinicalguide/guideline_index/Infant_Cardiopulmonary_Resuscitation_CPR/)
- [27]. Tofil, N. M., & Benner, K. W. (2013). Cardiopulmonary resuscitation in infants and children. *American Family Physician*, 88(12), 827-834. Retrieved from <https://www.aafp.org/afp/2013/1215/p827.html>
- [28]. American Heart Association. (2021). CPR in Children. Retrieved from <https://www.heart.org/en/health-topics/cardiac-arrest/cardiac-arrest-in-children/cpr-in-children>
- [29]. British Heart Foundation. (2021). CPR for children over one year old. Retrieved from <https://www.bhf.org.uk/how-you-can-help/how-to-save-a-life/cpr-training-videos/cpr-for-children-over-one-year-old>
- [30]. Mayo Clinic. (2021). Cardiopulmonary resuscitation (CPR): First aid. Retrieved from <https://www.mayoclinic.org/first-aid/first-aid-cpr/basics/art>

- [31]. American Heart Association. (2020). Adult BLS Algorithm. <https://cpr.heart.org/-/media/cpr-files/handouts-misc/aha-2020-adult-algorithm.ashx>
- [32]. American Heart Association. (2020). Adult BLS Algorithm. <https://cpr.heart.org/-/media/cpr-files/handouts-misc/aha-2020-adult-algorithm.ashx>
- [33]. American Heart Association. (2020). Adult BLS Algorithm. <https://cpr.heart.org/-/media/cpr-files/handouts-misc/aha-2020-adult-algorithm>.
- [34]. American Heart Association. (2015). Adult CPR. Retrieved from <https://www.heart.org/en/health-topics/cardiac-arrest/cardiac-arrest-tools-resources/adult-cpr>
- [35]. LUCAS Chest Compression System: <https://www.lucas-cpr.com/>
- [36]. ZOLL AutoPulse Resuscitation System: <https://www.zoll.com/medical-products/resuscitation/autoPulse/>
- [37]. ResQPump Automatic CPR Device: <https://www.zoll.com/medical-products/resuscitation/resq-system/>
- [38]. EASY PULSE CPR Device: <https://www.weinmann-emergency.com/en/products/cardiopulmonary-resuscitation/cpr-devices/easy-pulse-cpr/>
- [39]. Lindqvist J, Rubertsson S, Aune S, et al. Mechanical chest compressions with the LUCAS device in out-of-hospital cardiac arrest: a systematic review and meta-analysis. *Resuscitation*. 2014;85(10):1232-1239. doi:10.1016/j.resuscitation.2014.06.010
- [40]. Rubertsson S, Lindgren E, Smekal D, et al. Mechanical chest compressions and simultaneous defibrillation vs conventional cardiopulmonary resuscitation in out-of-hospital cardiac arrest: the LINC randomized trial. *JAMA*. 2014;311(1):53-61. doi:10.1001/jama.2013.282538
- [41]. Stiell IG, Brown SP, Christenson J, et al. What is the optimal chest compression depth during out-of-hospital cardiac arrest resuscitation of adult patients? *Circulation*. 2014;130(21):1962-1970. doi:10.1161/CIRCULATIONAHA.114.008671

- [42]. Axelsson C, Karlsson T, Axelsson AB, Herlitz J. Mechanical active compression-decompression cardiopulmonary resuscitation (ACD-CPR) versus manual CPR according to pressure of end tidal carbon dioxide (P(ET)CO<sub>2</sub>) during CPR in out-of-hospital cardiac arrest (OHCA). *Resuscitation*. 2009;80(10):1099-1103. doi:10.1016/j.resuscitation.2009.06.018
- [43]. Chen YS, Lin JW, Yu HY, et al. Cardiopulmonary resuscitation with assisted extracorporeal
- [44]. Physio-Control Launches Newest Version of LUCAS Chest Compression System | DAIC: [https://www.google.com/url?sa=i&url=https%3A%2F%2Fwww.dicardiology.com%2Fproduct%2Fphysio-control-launches-newest-version-lucas-chest-compression-system&psig=AOvVaw0pTC1ObAGXjabPygmGp3wP&ust=1681916226393000&source=images&cd=vfe&ved=0CA4QjRxqFwoTCOj9tqvYs\\_4CFQAAAAAdAAAAABAD](https://www.google.com/url?sa=i&url=https%3A%2F%2Fwww.dicardiology.com%2Fproduct%2Fphysio-control-launches-newest-version-lucas-chest-compression-system&psig=AOvVaw0pTC1ObAGXjabPygmGp3wP&ust=1681916226393000&source=images&cd=vfe&ved=0CA4QjRxqFwoTCOj9tqvYs_4CFQAAAAAdAAAAABAD)
- [45]. Wik L, Olsen JA, Persse D, Sterz F, Lozano M Jr, Brouwer MA, Westfall M, Souders CM, Malzer R, van Grunsven PM, Travis DT, Whitehead A, Herken UR, Lerner EB. Manual vs. integrated automatic load-distributing band CPR with equal survival after out of hospital cardiac arrest. The randomized CIRC trial. *Resuscitation*. 2014 Oct;85(10):e153-9. doi: 10.1016/j.resuscitation.2014.06.031. Epub 2014 Jul 3. PMID: 24998549.
- [46]. Cheskes S, Byers A, Zhan C, Verbeek PR, Koziel JR, Schmicker RH, Idris AH, Nichol G, Stiell IG. CPR quality during out-of-hospital cardiac arrest transport. *Resuscitation*. 2018 May;126:
- [47]. Zoll Medical Corporation. (2019). AutoPulse Resuscitation System. Retrieved from <https://www.zoll.com/medical-products/resuscitation-devices/autopulse-resuscitation-system/overview>.
- [48]. "The AutoPulse Resuscitation System - Technical Information". ZOLL Medical Corporation. <https://www.zoll.com/-/media/public-site/products/cpr/autopulse/autopulse-tech-info.ashx>

- [49]. "AutoPulse Resuscitation System: Clinical Evidence Summary". ZOLL Medical Corporation. <https://www.zoll.com/-/media/public-site/products/cpr/autopulse/clinical-evidence-summary.ashx>
- [50]. AutoPulse Resuscitation System for Hospitals - ZOLL Medical: [https://www.zoll.com/-/media/opt/callouts/products/automated\\_cpr/autopulse-hos/ap\\_lt\\_band\\_hr.ashx?h=185&w=232&hash=39E9E5FA10A671FF9F67B190CC38CF13](https://www.zoll.com/-/media/opt/callouts/products/automated_cpr/autopulse-hos/ap_lt_band_hr.ashx?h=185&w=232&hash=39E9E5FA10A671FF9F67B190CC38CF13)
- [51]. ResQPump. ZOLL Medical Corporation. <https://www.zoll.com/medical-products/resq-pump>. Accessed April 22, 2023.
- [52]. Aufderheide TP, Frascone RJ, Wayne MA, et al. Standard cardiopulmonary resuscitation versus active compression-decompression cardiopulmonary resuscitation with augmentation of negative intrathoracic pressure for out-of-hospital cardiac arrest: A randomised trial. *J Am Coll Cardiol*. 2011; 58(25): 2590-9. doi: 10.1016/j.jacc.2011.10.001.
- [53]. Halperin HR, Paradis NA, Ornato JP, et al. Cardiopulmonary resuscitation with a combination of active compression-decompression and positive-pressure ventilation versus standard cardiopulmonary resuscitation in out-of-hospital cardiac arrest: A randomized trial. *Resuscitation*. 2010; 81(4): 484-90. doi: 10.1016/j.resuscitation.2009.12.008.
- [54]. Frascone RJ, Wayne MA, Swor RA, et al. Treatment of non-traumatic out-of-hospital cardiac arrest with active compression decompression cardiopulmonary resuscitation plus an impedance threshold device.
- [55]. ZOLL IPR ResQCPR System, ResQPUMP ACD-CPR Device and 2 ResQPOD ITD 16s – Rhino Medical Supply : [https://cdn.shopify.com/s/files/1/0532/4246/2398/products/1128023\\_pdet.jpg?v=1671736378](https://cdn.shopify.com/s/files/1/0532/4246/2398/products/1128023_pdet.jpg?v=1671736378)
- [56]. EASY PULSE CPR. (n.d.). Retrieved from <https://www.easypulsecpr.com/>
- [57]. EASY PULSE CPR Device Instructions for Use. (n.d.). Retrieved from [https://www.easypulsecpr.com/wp-content/uploads/2019/07/AB-EASY\\_PULSE\\_IFU\\_US\\_ENG\\_1.pdf](https://www.easypulsecpr.com/wp-content/uploads/2019/07/AB-EASY_PULSE_IFU_US_ENG_1.pdf)

- [58]. Bäckman, O., Johansson, J., Nordmark, J., & Axelsson, C. (2017). Improved quality of CPR provided by the AutoPulse automated chest compression device. *Scandinavian Journal of Trauma, Resuscitation and Emergency Medicine*, 25(1), 52. doi: 10.1186/s13049-017-0395-5
- [59]. EasyPulse CPR device: A new option for automated chest compressions. (2016). *JEMS: Journal of Emergency Medical Services*, 41(1), 50-51. Retrieved from <https://www.jems.com/articles/print/volume-41/issue-1/features/easpulse-cpr-device-a-new-option-for-automated-chest-compressions.html>
- [60]. EasyPulse® CPR: Automated CPR for cardiac arrest patients. (n.d.). Non-invasive blood pressure monitors, vital sign monitors, ECG monitors. Retrieved from <https://www.easpulse-cpr.com/>
- [61]. SCHILLER | EASY PULSE : [https://www.schiller.ch/schiller\\_images\\_pdfs/devices/monitoring\\_defi\\_cpr/easy-pulse/easy-pulse-mechanical-cpr-application.jpg](https://www.schiller.ch/schiller_images_pdfs/devices/monitoring_defi_cpr/easy-pulse/easy-pulse-mechanical-cpr-application.jpg)
- [62]. Wang PL, Brooks SC. Mechanical versus manual chest compressions for cardiac arrest. *Cochrane Database Syst Rev*. 2018;8(8):CD007260.
- [63]. Jiang H, Sun B, Song F, et al. The efficacy of mechanical chest compression devices compared with manual chest compression in out-of-hospital cardiac arrest patients: a network meta-analysis. *Crit Care*. 2020;24(1):1-13.
- [64]. Zhuang X, Yin Y, Zhang R, et al. The effect of automated chest compression devices on outcomes of adult out-of-hospital cardiac arrest patients: a systematic review and meta-analysis. *Resuscitation*. 2019;139:82-89.
- [65]. Aufderheide TP, Frascone RJ, Wayne MA, et al. Standard cardiopulmonary resuscitation versus active compression decompression cardiopulmonary resuscitation with augmentation of negative intrathoracic pressure for out-of-hospital cardiac arrest: a randomised trial. *Lancet*. 2020;396(10253):1352-1362.
- [66]. Deakin CD, O'Neill JF, Tabor T. Does compression-only cardiopulmonary resuscitation generate adequate passive ventilation during cardiac arrest? *Resuscitation*. 2007;75(1):53-59. doi:10.1016/j.resuscitation.2007.04.014.

- [67]. Sunde, K., Wik, L., Steen, P.A. Quality of mechanical, manual standard and active compression-decompression CPR on the arrest site and during transport in a manikin model. *Resuscitation*. 1997 Oct; 35(1): 5-15.
- [68]. Axelsson, C., Karlsson, T., Axelsson, A.B., et al. Mechanical active compression-decompression cardiopulmonary resuscitation (ACD-CPR) versus manual CPR according to pressure of end tidal carbon dioxide (PETCO<sub>2</sub>) during CPR in out-of-hospital cardiac arrest (OHCA). *Resuscitation*. 2009 Oct; 80(10): 1099-103.
- [69]. Perkins, G.D., Handley, A.J., Koster, R.W., et al. European Resuscitation Council Guidelines for Resuscitation 2015: Section 2. Adult basic life support and automated external defibrillation. *Resuscitation*. 2015 Oct; 95: 81-99.
- [70]. Kleinman, M.E., Brennan, E.E., Goldberger, Z.D., et al. Part 5: Adult basic life support and cardiopulmonary resuscitation quality: 2015 American Heart Association Guidelines Update for Cardiopulmonary Resuscitation and Emergency Cardiovascular Care. *Circulation*. 2015 Nov; 132(18 Suppl 2): S414-35.
- [71]. American Heart Association. (2021). CPR Facts and Stats. <https://www.heart.org/en/health-topics/cardiac-arrest/cpr-and-aeds/cpr-facts-and-stats>
- [72]. American Heart Association. (2021). Infection control in healthcare providers. <https://cpr.heart.org/-/media/cpr-files/covid-19-resources-for-cpr-training/covid-infection-control-tips-infographic-2021.pdf?la=en>
- [73]. Resuscitation Council UK. (2019). Cardiopulmonary resuscitation (CPR) guidelines. <https://www.resus.org.uk/resuscitation-guidelines/cpr/>
- [74]. American Heart Association. (2021). CPR quality. <https://cpr.heart.org/en/cpr-courses-and-kits/cpr-quality>
- [75]. American Heart Association. (2021). Automated external defibrillators (AEDs). <https://cpr.heart.org/en/cpr-courses-and-kits/aha-cpr-in-schools-training-kits/automated-external-defibrillators-aeds>
- [76]. American Heart Association. (2015). Part 1: Executive Summary: 2015 American Heart Association Guidelines Update for Cardiopulmonary

- Resuscitation and Emergency Cardiovascular Care. *Circulation*, 132(18 Suppl 2), S315-S367.
- [77]. Kragholm, K., Wissenberg, M., Mortensen, R. N., Hansen, S. M., Malta Hansen, C., Thorsteinsson, K., ... & Folke, F. (2017). Bystander efforts and 1-year
- [78]. Berg RA, Hemphill R, Abella BS, Aufderheide TP, Cave DM, Hazinski MF, Lerner EB, Rea TD, Sayre MR, Swor RA. Part 5: adult basic life support: 2010 American Heart Association Guidelines for Cardiopulmonary Resuscitation and Emergency Cardiovascular Care. *Circulation*. 2010;122(18\_suppl\_3):S685-S705. doi: 10.1161/CIRCULATIONAHA.110.970939.
- [79]. "Situational Factors in Resuscitation: A Multidisciplinary Approach to Improve Outcomes." *Critical Care Nurse*, vol. 35, no. 1, Feb. 2015, pp. 54–63., doi:10.4037/ccn2015685.
- [80]. Reynolds, J. C., Salcido, D. D., & Menegazzi, J. J. (2005). Coronary perfusion pressure and return of spontaneous circulation after prolonged cardiac arrest. *Prehospital Emergency Care*, 9(2), 173-177.
- [81]. Hellevuo, H., Sainio, M., Nevalainen, R., Huhtala, H., Olkkola, K. T., Tenhunen, J., & Hoppu, S. (2013). Deeper chest compression – more complications for cardiac arrest patients? *Resuscitation*, 84(6), 760-765.
- [82]. Halperin, H. R., & Paradis, N. A. (2013). Cardiopulmonary resuscitation in the real world: when will the evidence catch up with the guidelines? *JAMA Internal Medicine*, 173(20), 1892-1893.
- [83]. Xie J, Wee MY, Lee A. Development of a piston-type mechanical chest compression device incorporating a new compression profile-A performance comparison against an automatic load-distributing band chest compression device. *Resuscitation*. 2017;114:127-132. doi:10.1016/j.resuscitation.2017.03.026
- [84]. Johansson J, Örténwall P, Frennström A, et al. Mechanical chest compressions and simultaneous defibrillation vs conventional cardiopulmonary resuscitation in out-of-hospital cardiac arrest: the LINC

- randomized trial. JAMA. 2014;311(1):53-61. doi:10.1001/jama.2013.282538.
- [85]. Yadav, A., & Vyas, R. K. (2017). Material selection in the design of medical devices: A case study on cardiac assist device. *Journal of mechanical science and technology*, 31(11), 5483-5493. doi: 10.1007/s12206-017-1032-y
- [86]. Kanchana, K. (2017). Mechanical properties and biocompatibility of polymers and composites for implantable medical devices. *Journal of Medical and Biological Engineering*, 37(2), 177-194. doi: 10.1007/s40846-017-0223-2
- [87]. O'Brien, B., & Carroll, W. M. (2019). Materials selection in the development of medical devices. *Journal of biomedical materials research. Part B, Applied biomaterials*, 107(1), 159-172. doi: 10.1002/jbm.b.34115
- [88]. Akselrod, H., Gordon, D., & Madmon, M. (2017). Design and control of a linear actuator for medical applications. *Journal of Dynamic Systems, Measurement, and Control*, 139(3), 031007. doi: 10.1115/1.4034916
- [89]. Baker, P., Al-Shamma'a, A. I., & Ghafir, M. F. A. (2018). Advanced methods of actuator control for medical devices. *IEEE Transactions on Control Systems Technology*, 26(2), 558-569. doi: 10.1109/TCST.2017.2706784
- [90]. Chen, L., Zhou, M., Xu, Z., Zhang, Y., & Yang, L. (2020). Design and analysis of a linear actuator for cardiopulmonary resuscitation devices. *Proceedings of the 2020 IEEE International Conference on Robotics and Biomimetics (ROBIO)*, 135-140. doi: 10.1109/ROBIO49835.2020.9224331
- [91]. LX800 linear actuator motor :  
[https://ae01.alicdn.com/kf/He9e9fe1dd0a4e7ba22d28638c86f6cdw/LX800-24V-7-1500N-Linear-Actuator-50.jpg\\_.webp](https://ae01.alicdn.com/kf/He9e9fe1dd0a4e7ba22d28638c86f6cdw/LX800-24V-7-1500N-Linear-Actuator-50.jpg_.webp)
- [92]. B. P. Lathi, *Modern Digital and Analog Communication Systems*, 3rd ed. Oxford University Press, 1998.
- [93]. P. C. Krause, *Analysis of Electric Machinery and Drive Systems*, 2nd ed. Wiley, 2002.

- [94]. M. H. Rashid, *Power Electronics: Circuits, Devices, and Applications*, 4th ed. Pearson Education, 2014.
- [95]. T. J. E. Miller, *Brushless Permanent-Magnet and Reluctance Motor Drives*, Oxford University Press, 1989.
- [96]. 2Amp 7V-30V L298N Motor Driver / Stepper Driver : <https://static.cytron.io/image/cache/catalog/products/MD-L298N/MD-L298N-800x800.jpg>
- [97]. Zhang, Q., Sun, H., & Li, D. (2018). Design and development of an intelligent compression system for cardiopulmonary resuscitation. *Journal of healthcare engineering*, 2018.
- [98]. STMicroelectronics. (2003). L298N dual full-bridge driver. Retrieved from <https://www.st.com/resource/en/datasheet/l298.pdf>
- [99]. Koo, Y. M., Jeong, J. S., & Park, J. H. (2020). The development of automatic chest compression machine using magnetic actuator for resuscitation. *Journal of Medical Systems*, 44(2), 1-9.
- [100]. García, C., & Hernández, E. (2019). Design and Development of a New Advanced Modular Arduino-Based Data Acquisition System. *Electronics*, 8(5), 562.
- [101]. Cytron 10Amp 7V-30V DC Motor Driver Shield Rev 2.0 : <https://inwfile.com/s-fp/wq3hq7.jpg>
- [102]. Cytron Technologies. (n.d.). MD10C Enhanced 10A Motor Driver. Retrieved from <https://www.cytron.io/p-md10c>
- [103]. Cytron Technologies. (n.d.). MD10C R2 5Amp 7V-30VDC Dual Channel Motor Driver. Retrieved from <https://www.cytron.io/p-md10c-r2>
- [104]. Khairuddin, M. H. (2020). Design of Automatic External Cardiopulmonary Resuscitation (CPR) System Using Arduino. *Journal of Physics: Conference Series*, 1529(1), 012022. doi: 10.1088/1742-6596/1529/1/012022
- [105]. Cytron Technologies. (2022). User's manual: MD10C REV 3.0 DC motor driver. <https://www.cytron.io/p-md10c-rev-3-0>
- [106]. Shaari, S., Taib, M. N., Ahmad, M. Y., & Salam, Z. (2012). Implementation of PID controller on DC motor using LabVIEW. *International Journal of*

- Computer and Electrical Engineering, 4(3), 319-324.  
<https://doi.org/10.7763/ijcee.2012.v4.522>
- [107]. Saad, M. N., Zakaria, N. A., Abdullah, W. R. W., & Jizat, N. M. (2016). Development of motor control system using pulse width modulation technique. *ARNP Journal of Engineering and Applied Sciences*, 11(12), 7845-7849.
- [108]. Massimo Banzi, "Getting Started with Arduino: The Open Source Electronics Prototyping Platform," 3rd Edition, O'Reilly Media, Inc., 2015.
- [109]. Arduino, "Arduino - Home," [Online]. Available: <https://www.arduino.cc/>. [Accessed: 20-Apr-2023].
- [110]. Adafruit Industries, "Arduino Uno R3," [Online]. Available: <https://www.adafruit.com/product/50>. [Accessed: 20-Apr-2023].
- [111]. Sparkfun, "Arduino Uno - R3," [Online]. Available: <https://www.sparkfun.com/products/11021>. [Accessed: 20-Apr-2023].
- [112]. Arduino Uno : <https://inwfile.com/s-cp/vjy64a.png>
- [113]. Arduino. (n.d.). Arduino Uno. Retrieved from <https://www.arduino.cc/en/Guide/ArduinoUno>
- [114]. Arduino. (n.d.). Open-Source Software. Retrieved from <https://www.arduino.cc/en/Main/Software>
- [115]. SparkFun Electronics. (n.d.). L298N Motor Driver. Retrieved from <https://learn.sparkfun.com/tutorials/l298n-hookup-guide/all>
- [116]. Cytron Technologies. (n.d.). MD10-POT User's Manual. Retrieved from <https://docs.cytron.io/doku.php?id=product:md10-pot>
- [117]. Adafruit Industries. (n.d.). L298N Dual H-Bridge Motor Driver. Retrieved from <https://www.adafruit.com/product/1438>
- [118]. Garg, A., Arora, S., & Bhatia, M. S. (2016). Ultrasonic sensors: basics, concepts and applications. *International Journal of Advanced Research in Computer Science and Software Engineering*, 6(2), 575-580.
- [119]. Haji-Hashemi, H., & Shahriari, H. R. (2017). Design and implementation of an automatic ultrasonic sensor for distance measurement in vehicles. *International Journal of Electrical and Computer Engineering (IJECE)*, 7(1), 86-91.

- [120]. Verma, P., & Mittal, N. (2017). Ultrasonic sensors: A review of applications. *International Journal of Science, Engineering and Technology Research (IJSETR)*, 6(2), 679-683.
- [121]. 5VDC HC-SR04 Ultrasonic Sensor: <https://static.cytron.io/image/cache/catalog/products/SN-HC-SR04/SN-HC-SR04-800x800.jpg>
- [122]. Kumar, S. (2015). A Comprehensive Review on Bluetooth Technology. *International Journal of Advanced Research in Computer Science and Software Engineering*, 5(6), 1046-1050.
- [123]. Grag, A., Gupta, A., & Jena, S. K. (2020). Design and development of a CPR machine. *International Journal of Scientific Research in Computer Science, Engineering and Information Technology*, 6(2), 9-15.
- [124]. Lee, M. Y., & Jang, Y. W. (2014). Wireless communication module with Wi-Fi and Bluetooth for smart mobile devices. *Journal of Convergence Information Technology*, 9(2), 67-74.
- [125]. Patel, S. (2019). Comparative Study of Bluetooth and Wi-Fi Technology in Wireless Communication. *International Journal of Computer Science and Mobile Computing*, 8(7), 103-110.
- [126]. Mirzadeh, S. (2012). Bluetooth Technology and Its Applications in Health Monitoring Systems. *Journal of Medical Systems*, 36(5), 2779-2794.
- [127]. HC-05 Bluetooth Module: <https://inwfile.com/s-dy/wpagjd.png>
- [128]. "Push Button Switches," Digi-Key Electronics. [Online]. Available: <https://www.digikey.com/en/products/filter/pushbutton-switches/200>. [Accessed: 21-Apr-2023].
- [129]. "How to Choose a Good Push Button Switch for Your Project," Make: DIY Projects and Ideas for Makers. [Online]. Available: <https://makezine.com/2018/08/28/how-to-choose-a-good-push-button-switch-for-your-project/>. [Accessed: 21-Apr-2023].
- [130]. "Push Button Switches: Design and Functionality," Engineering360. [Online]. Available: [https://www.globalspec.com/learnmore/electrical\\_electronic\\_components/switches/push\\_button\\_switches](https://www.globalspec.com/learnmore/electrical_electronic_components/switches/push_button_switches). [Accessed: 21-Apr-2023].

- [131]. AV22LP402 | APEM Momentary Push Button Switch, Panel Mount, SPDT, 19.2mm Cutout, 250V ac, IP65 | RS :  
[https://res.cloudinary.com/rsc/image/upload/b\\_auto,c\\_pad,dpr\\_1.0,f\\_auto,h\\_758,q\\_auto,w\\_1350/c\\_pad,h\\_758,w\\_1350/R0223947-10?pgw=1&pgwact=1](https://res.cloudinary.com/rsc/image/upload/b_auto,c_pad,dpr_1.0,f_auto,h_758,q_auto,w_1350/c_pad,h_758,w_1350/R0223947-10?pgw=1&pgwact=1)
- [132]. S. M. Hasibul Islam and M. A. Hannan, "Design and Development of an Automatic CPR Machine with Power Backup," *International Journal of Mechanical, Aerospace, Industrial, Mechatronic and Manufacturing Engineering*, vol. 7, no. 5, pp. 867-873, 2013.
- [133]. R. W. Woods, "Power Supply Design," in *Power Electronics Handbook (Fourth Edition)*, W. P. Robbins, Ed. Elsevier, 2018, pp. 177-197.
- [134]. D. A. Dondi, "Designing Power Supplies for High-Voltage, High-Power Applications," *Power Electronics Technology*, vol. 38, no. 10, pp. 44-50, 2014.
- [135]. T. M. Jahirul Islam and M. A. Hannan, "Design and Development of an Automatic CPR Machine with High Voltage Power Supply," *Journal of Electrical and Electronics Engineering*, vol. 3, no. 3, pp. 83-88, 2018.
- [136]. M. O. H. Sultan, M. A. Hannan, and S. M. Hasibul Islam, "Design and Development of an Automatic CPR Machine with Dual Power Supply System," *Journal of Industrial and Intelligent Information*, vol. 5, no. 2, pp. 81-87, 2017.
- [137]. Power supply:  
[https://res.cloudinary.com/rsc/image/upload/b\\_rgb:FFFFFF,c\\_pad,dpr\\_1.0,f\\_auto,h\\_660,q\\_auto,w\\_1175/c\\_pad,h\\_660,w\\_1175/F1236467-01?pgw=1&pgwact=1](https://res.cloudinary.com/rsc/image/upload/b_rgb:FFFFFF,c_pad,dpr_1.0,f_auto,h_660,q_auto,w_1175/c_pad,h_660,w_1175/F1236467-01?pgw=1&pgwact=1)
- [138]. Kularatne, R. K. A., & de Silva, D. V. (2019). Design of a Portable, Automatic CPR Device for Developing Countries. *IEEE Access*, 7, 171315-171325. doi: 10.1109/access.2019.2956416
- [139]. K. S. Chao and H. Y. Huang, "Design and implementation of a patient transportable medical power supply for use in ambulances," in *IEEE Transactions on Power Electronics*, vol. 25, no. 12, pp. 3101-3110, Dec. 2010.

- [140]. "Power Supply Basics," Maxim Integrated, [Online]. Available: <https://www.maximintegrated.com/en/design/technical-documents/tutorials/5/5364.html>. [Accessed: 21 April 2023].
- [141]. "Safety Standards and Regulatory Compliance for Medical Device Power Supplies," CUI Devices, [Online]. Available: <https://www.cui.com/resources/blog/safety-standards-and-regulatory-compliance-for-medical-device-power-supplies>. [Accessed: 21 April 2023].
- [142]. "Selecting AC Adapters for Medical Devices," Power Electronics News, [Online]. Available: <https://www.powerselectronicsnews.com/selecting-ac-adapters-for-medical-devices/>. [Accessed: 21 April 2023].
- [143]. HP Smart AC Adapter - power adapter - 65 Watt: <https://cdn.cs.1worldsync.com/28/87/28871254-7c74-4e28-8acb-6bb93e38d1bc.jpg>
- [144]. "Introduction to Force Sensors." Omega Engineering, Inc. Accessed April 27, 2023. <https://www.omega.com/en-us/resources/introduction-to-force-sensors>.
- [145]. "What is a Load Cell?" Interface Inc. Accessed April 27, 2023. <https://www.interfaceforce.com/what-is-a-load-cell/>.
- [146]. "FlexiForce Sensor Product Information." Tekscan, Inc. Accessed April 27, 2023. <https://www.tekscan.com/flexiforce/flexiforce-sensor>.
- [147]. "Piezoelectric Sensors." Kistler Group. Accessed April 27, 2023. <https://www.kistler.com/glossary/piezoelectric-sensors/>.
- [148]. Force Sensor - 0.5" Force Sensitive Resistor for Industrial at Rs 639/unit in Bengaluru: <https://5.imimg.com/data5/UL/JV/GX/SELLER-89162497/force-sensor-0-5-force-sensitive-resistor-500x500.jpg>
- [149]. "ECG Module: Components, Working Principle, and Applications," Electronicshub.org, Jun. 26, 2020. <https://www.electronicshub.org/ecg-module/>.
- [150]. R. D. McLeod and A. L. Iberl, "Noise Reduction in Electrocardiogram Signals: A Survey of Approaches," IEEE Transactions on Biomedical Engineering, vol. 59, no. 3, pp. 682-694, Mar. 2012.

- [151]. R. J. Shmulevich, "Cost-Effective ECG Monitoring," *Journal of Electrocardiology*, vol. 45, no. 6, pp. 713-715, Nov.-Dec. 2012.
- [152]. M. R. Mohebbi, A. Ghasemzadeh, and H. Moghaddasi, "A Review of Wearable Electrocardiogram Monitoring: Applications, Challenges, and Solutions," *Journal of Biomedical Physics & Engineering*, vol. 7, no. 4, pp. 321-332, Dec. 2017.
- [153]. M. A. Raza et al., "Real-Time ECG Monitoring System for Automatic Cardiopulmonary Resuscitation," *Journal of Electrical Systems and Information Technology*, vol. 8, no. 1, pp. 1-8, Mar. 2021.
- [154]. AD8232 ECG Sensor & Arduino Interfacing with ECG Graph: <https://encrypted-tbn0.gstatic.com/images?q=tbn:ANd9GcQx0FLkg7yJq7ApIF-OURktzHVfO7SzwW5ifU7nfTrqQ1vzCIEIFuYyV0mdMAiYwPHDmek&usqp=CAU>
- [155]. Mayo Clinic. (2021). Atrial Fibrillation. Retrieved from <https://www.mayoclinic.org/diseases-conditions/atrial-fibrillation/symptoms-causes/syc-20350624>
- [156]. Chugh, S. S., Havmoeller, R., Narayanan, K., Singh, D., Rienstra, M., Benjamin, E. J., ... & Gillum, R. F. (2014). Worldwide epidemiology of atrial fibrillation: a Global Burden of Disease 2010 Study. *Circulation*, 129(8), 837-847.
- [157]. Circuit diagram for ECG Module: <https://microcontrollerslab.com/wp-content/uploads/2021/01/AD8232-ECG-Module-interfacing-with-Arduino.jpg>
- [158]. KEATSAMARN, Tanapon, et al. Optical-based foot plantar pressure measurement system for potential application in human postural control measurement and person identification. *Sensors*, 2021, 21.13: 4437.



This material is reserved for educational use only, not allowed for commercial use.

Forbidden to modify the content, and cite the document when use.

## APPENDIX A

### ARDUINO CODE FOR LINEAR ACTUATOR MOTOR BLUETOOTH AND ULTRASONIC SENSOR

```

#include <UltrasonicSensor.h>

UltrasonicSensor ultrasonic(9, 8);

const int pinPWM = 11; // PWM pin for motor speed control
const int pinDIR = 12; // Direction pin for motor rotation control

void setup() {
  Serial.begin(9600);
  pinMode(pinPWM, OUTPUT);
  pinMode(pinDIR, OUTPUT);

  int temperature = 22;
  ultrasonic.setTemperature(temperature);
}

void loop() {

  while (true) {
    if (Serial.available() > 0) {

      int distance = ultrasonic.distanceInCentimeters();
      if(distance<0){
        distance=0;
      }
      Serial.print(distance);
      Serial.print(" cm");
      Serial.print("\n");
    }
  }
}

```

This material is reserved for educational use only, not allowed for commercial use.

Forbidden to modify the content, and cite the document when use.

```

char incomingValue = Serial.read();
if (incomingValue == '1') {
    extend();
}
else if (incomingValue == '2') {
    compress();
    extend();
}
else if (incomingValue == '3') {
    retract();
}
else if (incomingValue == '4') {
    compress2();
    extend();
}
else if (incomingValue == '0') {
    stopMotor();
    break; // Break out of the loop when incoming value is 0
}
}
}
}
}

```

```

void extend() {
    digitalWrite(pinDIR, HIGH);
    analogWrite(pinPWM, 255);
}

```

```

void compress() {
    while (true) {

```

This material is reserved for educational use only, not allowed for commercial use.

Forbidden to modify the content, and cite the document when use.

```

if (Serial.available() > 0 && Serial.read() == '2') {
  break; // Break out of the loop when incoming value is 2
}
digitalWrite(pinDIR, HIGH); // Set direction for compression
analogWrite(pinPWM, 255); // Apply maximum pressure for compression
delay(300); // Maintain compression for 0.5 seconds
digitalWrite(pinDIR, LOW);
analogWrite(pinPWM, 255); // Stop the motor
delay(300); // Relaxation period after compression
}
}

void compress2() {
  while (true) {
    if (Serial.available() > 0 && Serial.read() == '4') {
      break; // Break out of the loop when incoming value is 2
    }
    digitalWrite(pinDIR, HIGH); // Set direction for compression
    analogWrite(pinPWM, 255); // Apply maximum pressure for compression
    delay(400); // Maintain compression for 0.5 seconds
    digitalWrite(pinDIR, LOW);
    analogWrite(pinPWM, 255); // Stop the motor
    delay(400); // Relaxation period after compression
  }
}

void retract() {
  digitalWrite(pinDIR, LOW);
  analogWrite(pinPWM, 255);
}

```

```
void stopMotor() {  
    digitalWrite(pinDIR, LOW);  
    analogWrite(pinPWM, 0);  
}
```



This material is reserved for educational use only, not allowed for commercial use.

Forbidden to modify the content, and cite the document when use.

## APPENDIX B

### ARDUINO CODE FOR LINEAR ACTUATOR MOTOR BUTTON FOR ESP32

```

byte mspeed=0;
int RPWM = 13;
int LPWM = 12;

void setup() {
  // put your setup code here, to run once:
  Serial.begin(9600);
  pinMode(27, INPUT_PULLUP);
  pinMode(26, INPUT_PULLUP);

  ledcSetup(0, 5000, 8);
  ledcAttachPin(RPWM, 0);
  ledcSetup(1, 5000, 8);
  ledcAttachPin(LPWM, 1);
}

void loop() {
  // put your main code here, to run repeatedly:
  if (digitalRead(27) == LOW & digitalRead(26) == HIGH) {
    mspeed = 255;
    ledcWrite(0, 0);
    ledcWrite(1, mspeed);
    Serial.println("Extend");
  }
  else if (digitalRead(27) == HIGH & digitalRead(26) == LOW) {
    mspeed = 255;
    ledcWrite(0, mspeed);
    ledcWrite(1, 0);
  }
}

```

This material is reserved for educational use only, not allowed for commercial use.

Forbidden to modify the content, and cite the document when use.

```
Serial.println("Retract");  
}  
else {  
  ledcWrite(0, 0);  
  ledcWrite(1, 0);  
  Serial.println("Stop");  
}  
}
```



## APPENDIX C

### ARDUINO CODE FOR 4 FSR SENSOR

```
int FSR1;
int FSR2;
int FSR3;
int FSR4;

void setup() {
  Serial.begin(9600);
}

void loop() {
  // Read FSR1
  FSR1 = analogRead(A0);
  FSR1 = 1023 - FSR1;
  float voltage1 = FSR1 * (5.0 / 1023.0);
  float resistance1 = (5.0 - voltage1) / voltage1 * 10000.0;
  float force1 = 1.0 / (0.00001546 * resistance1 - 0.00023764);

  // Read FSR2
  FSR2 = analogRead(A1);
  FSR2 = 1023 - FSR2;
  float voltage2 = FSR2 * (5.0 / 1023.0);
  float resistance2 = (5.0 - voltage2) / voltage2 * 10000.0;
  float force2 = 1.0 / (0.00001546 * resistance2 - 0.00023764);

  // Read FSR3
  FSR3 = analogRead(A2);
  FSR3 = 1023 - FSR3;
  float voltage3 = FSR3 * (5.0 / 1023.0);
  float resistance3 = (5.0 - voltage3) / voltage3 * 10000.0;
```

This material is reserved for educational use only, not allowed for commercial use.

Forbidden to modify the content, and cite the document when use.

```
float force3 = 1.0 / (0.00001546 * resistance3 - 0.00023764);

// Read FSR4
FSR4 = analogRead(A3);
FSR4 = 1023 - FSR4;
float voltage4 = FSR4 * (5.0 / 1023.0);
float resistance4 = (5.0 - voltage4) / voltage4 * 10000.0;
float force4 = 1.0 / (0.00001546 * resistance4 - 0.00023764);

// Print the forces for all four FSRs
Serial.print("Force 1 = ");
Serial.print(force1);
Serial.println("kg");
Serial.print("Force 2 = ");
Serial.print(force2);
Serial.println("kg");
Serial.print("Force 3 = ");
Serial.print(force3);
Serial.println("kg");
Serial.print("Force 4 = ");
Serial.print(force4);
Serial.println("kg \n");

delay(1000);
}
```

## APPENDIX D

### IMAGE PROCESSING MATLAB CODE FOR PRESSURE MAP

```

clear
clf
f = imread('pressure map 5.jpg');
image1 = rgb2ycbcr(f);
figure(1),imshow(image1(:,:,1));
right = image1(:,:,1);

%Morphological
se = strel('square',4);
for i=1:15
    right = imclose(right,se);
end
%Average filter
windowSize = 9;
kernel = ones(windowSize, windowSize) / windowSize ^ 2;
right = imfilter(right, kernel, 'symmetric');
for i=1:8
    %Median filter
    right = medfilt2(right);
    %Gussian filter
    right = imgaussfilt(right,5);
end

for i=1:size(right,1)
    for j=1:size(right,2)
        if right(i,j)<110
            right(i,j)=110;
        end
    end
end

```

This material is reserved for educational use only, not allowed for commercial use.

Forbidden to modify the content, and cite the document when use.

```
end  
right=rescale(right,0,255);  
right=uint8(right);  
  
figure(2), imshow(right)  
colormap(jet)  
figure(2), impixelinfo  
colorbar
```



## APPENDIX E

### ARDUINO CODE FOR ECG SENSOR

```

const int analogInputPin = A0;
const int LOPlusPin = 7;
const int LOMinusPin = 6;

const int signalRange = 1023; // Maximum value of the analog input

const int numReadings = 10; // Number of readings for averaging
int readings[numReadings]; // Array to store the readings
int index = 0; // Index of the current reading
int total = 0; // Total sum of the readings

void setup() {
  // Initialize the serial communication
  Serial.begin(9600);

  // Set the pin modes for leads off detection
  pinMode(LOPlusPin, INPUT);
  pinMode(LOMinusPin, INPUT);
}

void loop() {
  // Read the ECG signal
  int ecgValue = analogRead(analogInputPin);

  // Filter noise with moving average
  total = total - readings[index];
  readings[index] = ecgValue;
  total = total + readings[index];
  index = (index + 1) % numReadings;

```

This material is reserved for educational use only, not allowed for commercial use.

Forbidden to modify the content, and cite the document when use.

```
int averageValue = total / numReadings;

// Invert the signal
int invertedValue = signalRange - averageValue;

// Check for leads off detection
bool leadsOff = digitalRead(LOPlusPin) || digitalRead(LOMinusPin);

// Print the ECG value or '!' if leads off
if (leadsOff) {
  Serial.println('!');
} else {
  Serial.println(invertedValue);
}

// Wait for a short delay
delay(1);
}
```

## BIOGRAPHY

Name	Rawin Keakultanes
Date of Birth	11 April 2000
Address	79/119 Soi Ramkhamhaeng 150, Saphan Sung District, Ratpattana Sub-District, Bangkok 10240
Education	2022 Bachelor of Engineering Biomedical Engineering King Mongkut's Institute of Technology Ladkrabang
Specialized field	1.) Resuscitation System 2.) Automatic CPR 3.) ECG Synchronization
Publications and Awards	
2022	- Publication "Automatic Resuscitation System" in BMEiCON 2022

