

CIEON INVENTORY MANAGEMENT SYSTEM

BY

Mr. Krittatee Thongsiriprapa

Ms. Jilaporn Pukasemvarangkool

Mr. Rapichat Sitthiworranant

**A PROJECT SUBMITTED IN PARTIAL FULFILLMENT OF THE
REQUIREMENTS FOR THE DEGREE OF BACHELOR OF
ENGINEERING IN COMPUTER INNOVATION ENGINEERING
KING MONGKUT'S INSTITUTE OF TECHNOLOGY
LADKRABANG
ACADEMIC YEAR 2020**

This material is reserved for educational use only, not allowed for commercial use.

Forbidden to modify the content, and cite the document when use

SCHOOL OF ENGINEERING
KING MONGKUT'S INSTITUTE OF TECHNOLOGY LADKRABANG
PROJECT CERTIFICATE

Project Title: CIEON Inventory Management System

Student Name: Mr. Krittatee Thongsiriprapa

Student ID. 60011228

Miss. Jilaporn Pukasemvarangkool

Student ID. 60011218

Mr. Rapichat Sitthiworant

Student ID. 60011264

Degree: Bachelor of Engineering in Computer
Innovation Engineering

Project Advisor Signed: _____
(Asst. Prof. Dr. Sutheera Puntheeranurak)

Project Advisor Signed: _____
(Asst. Prof. Dr. Panarat Cherntanom)

Project Title	CIEON Inventory Management System
Student Name	Mr. Krittatee Thognsiriprapa Miss. Jilaporn Pukasemvarangkool Mr. Rapichat Sitthiworant
Degree	Bachelor of Engineering in Computer Innovation Engineering
Project Advisor	Asst. Prof. Dr. Sutheera Puntheeranurak
Project Advisor	Asst. Prof. Dr. Panarat Cherntanom
Academic Years	2020

ABSTRACT

The goal of this research project is to develop a tool to reduce inventory management issues especially missing items by assisting companies with stock management, missing items, items and users' summaries, and item tracking status. The CIEON Inventory Management System is an add-on solution that helps to increase product security. Using the CIEON Inventory Management System website's functions to operate the lockers improves the system in terms of self-borrowing and self-returning.

This project has two aspects: software and hardware. Log in, borrow, return, reservation, extend, broken, lost, and enter OTP are the eight main features of the software part. Student, teacher, and admin are the three users of this system: each with different limitations of website usage. Students get access to the eight main features as teachers, except the time constraint and object amount. Admins have four main functions: edit, view, add, and delete. The hardware part detects the items by using RFID readers and RFID tags. PHP, HTML, and JavaScript language were tools used to develop CIEON Inventory Management System website.

This report describes the software and hardware design and provides an example of user interface, required equipment list, and methodology of this system.

ACKNOWLEDGEMENTS

Several significant encounters for work are provided through this project including aptitudes and capacities to match the appropriate ability by applying a wide range of knowledge. Without our companions in the Computer Innovation Engineering field, we were unable to have completed this project. Their suggestion, magnificent direction, support, and assistance for our improvement and development up until completion contributed to our success. Additionally, we genuinely appreciate the help from other staff whose names are not included for their help with offering us the assets for running the program.

We profoundly appreciate the project name, “CIEON Inventory Management System.” We would like to express our sincere gratitude towards our thesis supervisor Asst. Prof. Dr. Sutheera Puntheeranurak and Asst. Prof. Dr. Panarat Cherntanomwong for their valuable commitment and contribution to this project. We would not have accomplished the report without all the support from them. Finally, we would like to thank all the participation and supporters who helped us in this project.

Mr. Krittatee Thongsiriprapa

Ms. Jilaporn Pukasemvarangkool

Mr. Rapichat Sitthiworranant

TABLE OF CONTENTS

Topics	Page
ABSTRACT	(i)
ACKNOWLEDGEMENTS	(ii)
LIST OF TABLES	(vii)
LIST OF FIGURES	(viii)
LIST OF SYMBOLS/ABBREVIATIONS	(xiii)
CHAPTER 1 INTRODUCTION	1
1.1 Background	1
1.2 Objective	2
1.3 Scope	2
1.4 Method	2
1.5 Expected outcome	3
1.6 Table of operation	3
CHAPTER 2 REVIEW OF LITERATURE	5
2.1 Related software technology	5
2.1.1 Methods for front-end	5
2.1.2 Methods for back-end	5
2.2 Related hardware technology	8
2.2.1 Method of detection devices	8
2.2.2 Processing device	10
2.2.3 Output device	10

CHAPTER 3 METHODOLOGY	11
3.1 Introduction	11
3.2 Design methodology	11
3.2.1 Overall system	11
3.2.2 Hardware system	13
3.2.2.1 The hardware operation	13
3.2.2.2 Hardware state	13
3.2.3 Architecture of software	15
3.3 System development	28
3.3.1 Use case diagram	28
3.3.2 Sequence diagram	29
3.4 Database	56
3.4.1 ER diagram	56
3.4.2 Database table	57
3.5 Design business model	61
3.5.1 Define pain points and customer insight	61
3.5.2 Ideation and objective	61
3.5.3 Business model canvas	61
3.5.4 Business cost analysis	62
3.6 Summary	62
CHAPTER 4 EXPERIMENTAL RESULT	68
4.1 Introduction	68
4.2 Testing summary	68
4.2.1 Overall system	68
4.2.2 Software system	69
4.2.2.1 Authentication	69
4.2.2.2 Registration	69
4.2.2.3 Edit profile	69
4.2.2.4 Forget password	70
4.2.2.5 Homepage	70
4.2.2.6 Borrow	70

4.2.2.7 Return	71
4.2.2.8 Reserve	71
4.2.2.9 Broken	72
4.2.2.10 Lost	73
4.2.2.11 Enter OTP	73
4.2.2.12 Extend date/time	73
4.2.2.13 Add data	74
4.2.2.14 View data	74
4.2.2.15 Edit data	74
4.2.2.16 Delete data	74
4.2.2.17 Add item	75
4.2.2.18 History	75
4.2.2.19 Reports	75
4.2.2.20 Controlling locker	75
4.2.3 Hardware system	94
4.2.3.1 Locker part	94
4.2.3.2 Panel part	96
4.2.3.3 Door part	97
4.2.3.4 Item box part	98
4.3 Evaluation	99
CHAPTER 5 CONCLUSION	107
5.1 Introduction	107
5.2 Conclusions	107
5.3 Discussion	108
5.3.1 Interesting problems	109
5.3.2 Proposed solution	109
REFERENCES	110
APPENDICES	113
APPENDIX A	114

This material is reserved for educational use only, not allowed for commercial use.

Forbidden to modify the content and cite the document when use



LIST OF TABLES

Tables	Page
1.1 Table of operation time for first semester	3
1.2 Table of operation time for second semester	4
2.1 Table of advantage and disadvantage of detection device	9
3.1 Database user	58
3.2 Database locker	58
3.3 Database forget password token	58
3.4 Database item detail	59
3.5 Database category	59
3.6 Database reserve	60
3.7 Database activity	60



LIST OF FIGURES

Figures	Page
Figure 1.1 Workplace theft is on the rise	2
Figure 2.1 Authentication method	7
Figure 2.2 Example of navicat premium	7
Figure 2.3 Example of sql workbench	8
Figure 3.1 Architecture of full system	12
Figure 3.2 Architecture of hardware system	14
Figure 3.3 Architecture of login by using phpMyAdmin	17
Figure 3.4 Architecture of reservation feature	18
Figure 3.5 Architecture of borrow feature	19
Figure 3.6 Architecture of lost feature	20
Figure 3.7 Architecture of return feature	21
Figure 3.8 Architecture of broken feature	22
Figure 3.9 Architecture of extend date/time feature	23
Figure 3.10 Architecture of enter OTP feature	24
Figure 3.11 Architecture of controlling locker feature	25
Figure 3.12 Architecture of admin adds item	26
Figure 3.13 Architecture of admin feature	27
Figure 3.14 The use case diagram of a teacher and a student	28
Figure 3.15 The use case diagram of an admin	29
Figure 3.16 Diagram for user's login	43
Figure 3.17 Diagram for user's registration	43
Figure 3.18 Diagram for user's edit profile feature	44
Figure 3.19 Diagram for user's forget password feature	45
Figure 3.20 Diagram for user's reservation feature	46
Figure 3.21 Diagram for user's borrow feature	47
Figure 3.22 Diagram for user's return feature	48
Figure 3.23 Diagram for user's enter OTP feature	49
Figure 3.24 Diagram for user's lost feature	50

Figure 3.25 Diagram for user's broken feature	51
Figure 3.26 Diagram for user's extend feature	52
Figure 3.27 Diagram for admin's add data feature	53
Figure 3.28 Diagram for admin's view data feature	53
Figure 3.29 Diagram for admin's edit data feature	54
Figure 3.30 Diagram for admin's delete data feature	54
Figure 3.31 Diagram for admin's adds item feature	55
Figure 3.32 Diagram for admin's control locker feature	56
Figure 3.33 ER diagram of CIEON Inventory Management System	57
Figure 3.34 Business model canvas	63
Figure 3.35 CIEON Inventory Management System cost	64
Figure 3.36 Investment cost	65
Figure 3.37 Variable cost	65
Figure 3.38 Sample variable cost	66
Figure 3.39 CIE inventory expense in items	66
Figure 3.40 Return of investment and payback in CIE	67
Figure 3.41 Selling outsider cost	67
Figure 4.1 CIEON Inventory Management System	68
Figure 4.2 Login page	76
Figure 4.3 The system announces message "Username or password is incorrect. If you forgot your password, please use the 'forget password' button."	76
Figure 4.4 The registration form of student	76
Figure 4.5 The registration form of teacher	77
Figure 4.6 The edit profile page	77
Figure 4.7 The forget password page	78
Figure 4.8 The system announcement the email has sent to user's email	78
Figure 4.9 The change password page.	78
Figure 4.10 The offline homepage	79
Figure 4.11 The online homepage	79
Figure 4.12 The admin homepage	80
Figure 4.13 The borrow page	80
Figure 4.14 Example of using search items	81

Figure 4.15 Example of the item detail page	81
Figure 4.16 The system alerts message “Borrow over limit”	82
Figure 4.17 The system alerts message “Success”	82
Figure 4.18 Example of the borrow items cart	82
Figure 4.19 Example of the summarized page for the borrow feature	83
Figure 4.20 The system alerts message “Do you want to delete this item?”	83
Figure 4.21 The system alerts message “Do you want to delete all items?”	84
Figure 4.22 Example of the return page	84
Figure 4.23 The system sends message “Do you want to proceed?”	84
Figure 4.24 Example of the reserve page	85
Figure 4.25 Example of the item detail page	85
Figure 4.26 Example of reserve cart	86
Figure 4.27 Example of the summarized page for the reserve feature	86
Figure 4.28 The system alerts message “Do you want to delete this item?”	87
Figure 4.29 The system alerts message “Do you want to delete all items?”	87
Figure 4.30 Example of the broken page	87
Figure 4.31 The broken explanation detail box	88
Figure 4.32 Example of the penalty page	88
Figure 4.33 Example of the lost page	88
Figure 4.34 The system sends message “Do you want to proceed?”	89
Figure 4.35 Example of the penalty page	89
Figure 4.36 The enter OTP page	89
Figure 4.37 The system pops up after filling incorrectly OTP number incorrectly 3 times	89
Figure 4.38 The extend date/time page	90
Figure 4.39 Example of the add data page	90
Figure 4.40 Example of view data page on the top of the page	90
Figure 4.41 Example of view data page on the bottom of the page	91
Figure 4.42 Example of the view data page after clicking the edit icon	91
Figure 4.43 Example of the edit data page	91
Figure 4.44 Example of the delete data page	92
Figure 4.45 The page of adding items	92

Figure 4.46 The view item page after adding items without scanning the RFID tag	92
Figure 4.47 The view activity page of the history feature	93
Figure 4.48 The clear history page	93
Figure 4.49 Example of report page	93
Figure 4.50 Controlling locker page	94
Figure 4.51 Overall locker system	94
Figure 4.52 Outside locker system	95
Figure 4.53 Inside locker system	95
Figure 4.54 Screen on panel	96
Figure 4.55 RFID system	96
Figure 4.56 Door system	97
Figure 4.57 Overall door system	97
Figure 4.58 Example of box and item	98
Figure 4.59 Example of box number be separated by category type	98
Figure 4.60 Example of box number and RFID tags	99
Figure 4.61 The percentage of users who test the system in each role	99
Figure 4.62 The percentage of students who test the system	100
Figure 4.63 The scores of question no. 1	100
Figure 4.64 The scores of question no. 2	101
Figure 4.65 The scores of question no. 3	101
Figure 4.66 The scores of question no. 4	102
Figure 4.67 The scores of question no. 5	102
Figure 4.68 The scores of question no. 6	103
Figure 4.69 The scores of question no. 7	103
Figure 4.70 The scores of question no. 8	103
Figure 4.71 The scores of question no. 1 for admin	104
Figure 4.72 The scores of question no. 2 for admin	104
Figure 4.73 The scores of question no. 3 for admin	105
Figure 4.74 The scores of question no. 4 for admin	105
Figure 4.75 The scores of question no. 5 for admin	106
Appendix Figure A.1: Question about user profile	114
Appendix Figure A.2: Question about user satisfaction	115

Appendix Figure A.3: Question about system respond	115
Appendix Figure A.4: Question about user opinion	116
Appendix Figure A.5: Question about user satisfaction	116
Appendix Figure A.6: Question about system respond	117
Appendix Figure B.1: The admin homepage	118
Appendix Figure B.2: Example of the add data page	119
Appendix Figure B.3: The view item page after adding items without scanning the RFID tag	120
Appendix Figure B.4: The view item page after scanning the RFID tag	120
Appendix Figure B.5: Example of the view data page on the top of the page	121
Appendix Figure B.6: Example of the view data page on the bottom of the page	122
Appendix Figure B.7: The view activity page of the history feature	122
Appendix Figure B.8: The clear history page	123
Appendix Figure B.9: Example of the view report page	123
Appendix Figure B.10: Example of the delete data page	124
Appendix Figure B.11: Example of the view data page	125
Appendix Figure B.12: The editing page of student	125
Appendix Figure B.13: The system declares the message “Successfully edited the information”	125

LIST OF SYMBOLS/ABBREVIATIONS

Symbols/Abbreviations	Terms
CIE	Computer Innovation Engineering
SIIE	School of International Interdisciplinary Engineering Programs
RFID	Radio Frequency Identification
NFC	Near Field Communication
QR code	Quick Response Code
BLE beacon	Bluetooth Low Energy
IoT	Internet of Thing
OTP	One Time Password
GPIO	General Purpose Input/Output
m	Meter
cm	Centimeter
CSV	Comma-Separated Values

CHAPTER 1: INTRODUCTION

This chapter outlines the background information, objective, scope, methodology, and the expected outcome of CIEON Inventory Management Systems with the table of operation in this project.

1.1 Background

We cannot deny that the inventory management issue becomes one of the issues of numerous organizations that store valuable items. The tracking limitation system in organizations and missing items constitute a huge obstacle leading to the loss of cost in terms of replacing missing products. Some organizations waste expenses with ordering new items to replace the missing one, but sometimes they might find that particular item later.

According to Gershon's research in 2013 of 500 retail and service industry employees conducted by Kessler International, 95 percent of all businesses have encountered employee theft, and roughly 40 percent of employees have stolen from their employers [1]. Employee Theft Statistics from the Statistic Brain Research Institute in 2018 found that 75% of employees admitted to stealing from their workplace at least once [2]-[3].

According to figure 1.1, the graph demonstrates that workplace theft is on the rise, and that there will be a greater risk in the future. Due to the insecurity from workers in each organization, the tracking system is required to solve this problem to reduce the missing item as it can help the operator to track the usage and the condition of each item. Similarly, the assistant system will enable employees to borrow and return items with efficiency. CIEON Inventory Management System is a smart system incorporated to assist with inventory management systems by implementing a self-borrowing and a self-returning process. By gathering necessary data, such as item amount and status, the user who took the items, and the history of items and users, will help the owner to reduce the risk of missing and stolen items along with tracking users who took the items. The owner can follow the items and get more details about its status: borrow, return, lost, broken, and available. With the data from CIEON Inventory Management System website, the owner can recognize the current stock in the amount of available item, lost item, and broken item with a primary sign then fix it before returning it to be used in the system again. The owner can also look up the history of users who carried out some kind of process with the items via the online website. The implementation of CIEON Inventory Management System will benefit both employees and employers by deployment at the CIEON Inventory Management System process on the system website [4].

Workplace Theft Is on the Rise

The theft of noncash property jumped from 10.6 percent of business-theft cases in 2002 to 21 percent in 2018. Theft of noncash property now accounts for the highest percentage of fraud schemes at workplaces globally.

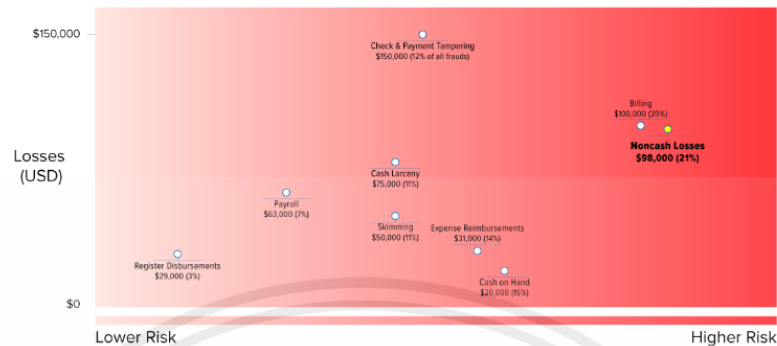

Source: Report to the Nations: 2018 Global Study on Occupational Fraud and Abuse by the Association of Certified Fraud Examiners.

Figure 1.1 Workplace theft is on the rise [4]

1.2 Objective

1. Implement a system that can identify and tracking missing items and users.
2. The system will be utilized as a tool for businesses to cope with stock management issues.
3. Apply the developing system by using knowledge from the IoT and Smart systems course.
4. Apply the website by using knowledge of the Human-Computer Interaction course.
5. The company can check the history of data which clarifies all information in this system.

1.3 Scope

1. Create a front-end and back-end web application with seven main features: borrow, return, reservation, extend date/time, broken, lost, and enter OTP, all of which interact with the hardware.
2. Design and implement the overall system, which includes both the software and hardware components and connects them to complete the system.
3. Create additional beneficial features for the admin, which include four functions: add, edit, view, and delete that link, as well as the ability to deal with data from the website and database.

1.4 Method

1. Designing the system's architecture and data structure.
2. Creating a database on server.
3. Designing and developing a website with a user-friendly approach in both the interface and user experience.
4. Creating the system by combining all the front-end and back-end, and testing all the functions to see that it works properly.
5. Deploying the website test run.

This material is reserved for educational use only, not allowed for commercial use.

1.5 Expected outcome

1. Users can reserve items from anywhere utilizing internet-connected device.
2. Users can pick up the item at the locker by entering the reservation OTP, which they received via email.
3. Users can use the system to do the self-borrowing and self-returning process.
4. The locker door opens in accordance with the selected item that users choose on the website.
5. The admin can use history, reports, adding data, editing data, viewing data and deleting data feature to adjudge information.

1.6 Table of operation

The table of operation describes the timeline and process of this project for two semesters.

According to table 1.1, the table shows the timeline of this project and each step-in semester 1. There are 2 main works in the first semester, which are preparation and implementation software.

Table 1.1: Table of operation time for first semester

Topic	Month											
	October				November				December			
	1	2	3	4	1	2	3	4	1	2	3	
1. Preparation												
Design architecture and database												
Design Frontend part												
Create a database and add information of users and items to the database												
2. Implementation Software												
Implement an authentication system												
Implement reservation and borrow system												
Implement enter OTP system												
Solenoid working with the website												

According to table 1.2, the table shows the operation time of this project and each step-in semester 2. There are 2 main works in the second semester, which are implementation hardware and implementation software.

Table 1.2: Table of operation time for second semester

Topic	Month																			
	January				February				March				April				May			
	1	2	3	4	1	2	3	4	1	2	3	4	1	2	3	4	1	2	3	4
1. Implementation Hardware																				
Research and ordering items	■	■	■	■																
Implement the detection item system					■	■	■	■	■											
RFID can be updated in database									■	■	■									
Implementing the solenoid system													■	■						
Implementing alarm														■	■		■	■		
Connecting with software																	■	■		
Setting all hardware																	■	■	■	■
2. Implementation Software																				
Redesign database	■	■	■	■	■	■	■	■	■											
Designing user interface					■	■	■	■	■											
Creating reservation and borrow system							■	■	■	■	■									
Creating and testing return, broken and enter OTP system													■	■	■	■				
Connecting with hardware part														■	■	■	■	■		
Creating lost, extend system and completing all admin page																	■	■		
Testing and fix debugging																			■	■

CHAPTER 2: LITERATURE REVIEW

This chapter consists of information about tools that are used for the software parts such as Bootstrap, HostNeverDie, HTML, PHP, CSS, and the hardware parts such as RFID, Buzzer Sensor, Raspberry Pi, Arduino Uno, Emitter, Transmitter, and panel. This chapter also explains each tool used for this project in detail.

2.1 Related software technology

Related software technology separates into two parts: method for front-end and method for backend.

2.1.1 Methods for front-end

The method for front-end consists of tools that are used to decorate, design, create, and export the front-end of this system.

- **Bootstrap** is a sophisticated front-end framework that is open source and can be used to create responsive websites. It includes a developed template that is built on CSS, HTML, and JavaScript and is ideal for using Bootstrap to develop a website. The team has chosen Bootstrap as a tool for improving user interface, and the coding language is one of the most capable of the languages we will employ in this project [5]-[6].
- **HostNeverDie** is a web hosting company that offers low-cost enterprise server hosting from Dell and Supermicro. The team selected HostNeverDie by using server from it [7].
- **HTML** is the most widely used programming language for building web pages. HTML enables web designers to create websites in their own unique style [8]-[9].
- **CSS** is a programming language for laying up and modifying HTML documents. It determines how HTML elements should appear on a website [10]-[11].
- **File Zilla** is the free file transfer protocol for both the client and server. It is an open-source software to transfer files from the local to the server [12].
- **Mobirise** is a free offline app for Window and Mac to design and create the website. The team uses Mobirise to simply design a draft before starting the implementation [13].

2.1.2 Methods for back-end

The method for back-end consists of tools that are used to design and create the back-end of this system.

- **Authentication method**

- The CIEON Inventory project manages MySQL databases with phpMyAdmin. We develop a database in MySQL to collect information regarding members, containing usernames and passwords for the use in the login page's authentication process. The PHP and HTML languages are used to develop the login page.

- From figure 2.1, we implemented by using the second method. To dedicate the login and registration system, we use phpMyAdmin, which can handle MySQL administration over the Web.

- To improve the security of our website, we encrypted and salted the password in addition to the security element of the authentication procedure. When users enter their username and password in the box and click the login button, the authentication procedure begins. By comparing the login and password to the information in the database, the system will ensure that they are correct.

- **MYSQLi()** is a feature that enables clients to connect to MySQL data base [14].

- **phpMyAdmin** is a free PHP-based programming tool for managing MySQL databases over the Internet [15].

- **PHP language** is a widely used open source globally useful scripting language that is especially suitable for web development and can be embedded in HTML. Furthermore, it is a common language for developing websites, and it can work with a wide range of data base dialects [16].

- **JavaScript** is a quick-to-learn, decoded, or quickly built programming language with top-notch capabilities. While JavaScript is best recognized as a web page scripting language, it is also utilized in non-programming apps like Node.js, Apache CouchDB, and Adobe Acrobat [17].

- **Navicat Premium** is a program that allows users to connect to MySQL and MariaDB databases. It also comes with the function of joining and creating tables. According to figure 2.2, inside the red square represents a table that uses with a relationship between table. Thus, inside the green square represent table inside the database [18].

- **SQL Workbench** is a database management system that runs on Windows, Linux, and Mac OS X. It provides data modeling, SQL development, and tools for server configuration. According to figure 2.3, the red square represents the tables that are used and its relationship between tables [19].

Typical server-based architecture



Implementation



Figure 2.1 Authentication method

The screenshot displays the Navicat Premium interface for a MySQL database named 'db_invfinal'. The 'Objects' pane on the left shows a tree view of the database structure. A green square highlights the 'Tables' folder, which contains several tables: 'tb_activity', 'tb_cate_item', 'tb_item_detail', 'tb_locker', 'tb_reserve', and 'tb_user'. A red square highlights the 'Relationships' pane, which shows a relationship between 'tb_cate_item' and 'tb_item_detail'. A line connects the 'item_id' field in 'tb_cate_item' to the 'item_detail_id' field in 'tb_item_detail'. A text box with a red border points to this relationship, stating: 'The red square represents table use and the line represents the relationship between tables.' Another text box with a green border points to the 'Tables' folder, stating: 'The green square represents all the tables inside the database.' The main window shows a query editor with a SQL query that lists various fields from the database tables.

Figure 2.2 Example of navicat premium

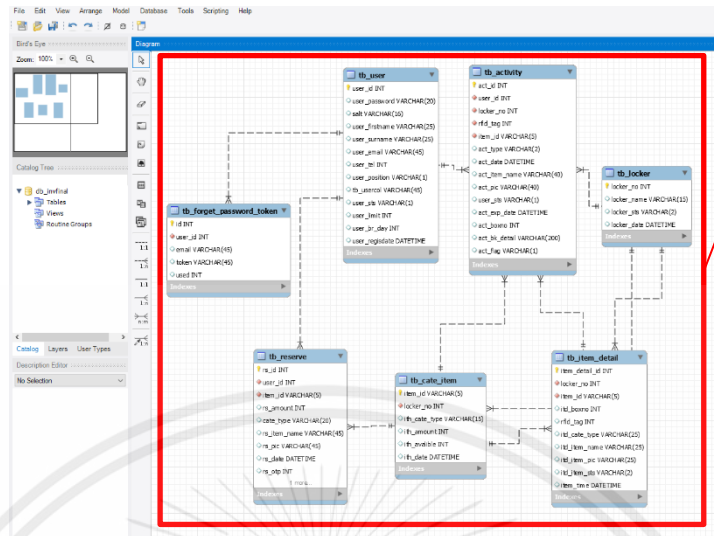

The red square represents table use and the line represents the relationship between tables.

Figure 2.3 Example of sql workbench

2.2 Related hardware technology

The sensor and gadget are required by the CIEON Inventory Management System to detect the item and track down the person who took it out. We conducted reader research and then assessed the pros and cons of each reader to identify the best technology for the system, as shown in table 2.1.

2.2.1 Method of detection devices

The method of detection devices describes each detection device that can be used in this system.

- **RFID**, or Radio Frequency Identification, is a system that captures and identifies data from RFID tags, which are small electronic tags. It can read several tags at the same time [20].
- **NFC**, or Near Field Communication, is a series of communication protocols that allows two devices to communicate with each other [21].
- **Barcode** is a numerical and character representation that can be read by any computer. It is divided into two parts: code scanner and barcode scanner [22].
- **QR code**, or Quick Response Code, is a form of matrix barcode that can be read by a smartphone or other digital devices. It keeps details in the form of a square grid of pixels [23]-[24].
- **BLE beacon**, or Bluetooth Low Energy, is a form of wireless communication designed for short-range communication [25]-[26].

To summarize, table 2.1 RFID is the suitable technology for the CIEON Inventory Management System since it is the only reader device that can detect several tags at once, giving the system a wide detection range.

- **Door sensor** is often used in the security field to detect and monitor accesses, such as doors and windows. “Entry sensor”, “contact sensors”, and “door sensor”, are all terms used to describe the door sensor. It is used for checking whether the door locker is closed or opened.

According to table 2.1, it displays the advantages and disadvantages of detection devices.

Table 2.1: Table of advantages and disadvantages of detection device

Readers	Advantages	Disadvantages
RFID	<ul style="list-style-type: none"> - Timesaving: It can scan multiple items at once. - RFID provide higher security than barcodes. - Automates data collection benefit. 	<ul style="list-style-type: none"> - The position for each item has to be fixed to enable the reader to read. - Higher cost for hardware implementation (RFID reader: around 13,000 Baht). - Each RFID Tag: 4-40 Baht. *The price does not include the import tax from the government. - Material limitations such as metal.
NFC	<ul style="list-style-type: none"> - Device can match with each other easier. - Require less power to complete a transaction. - Cheaper than RFID. 	<ul style="list-style-type: none"> - Extremely close range (10 cm). - Fastest data transfer is only 424 kbps (extremely slow). - Can scan only one item at a time.
Barcode	<ul style="list-style-type: none"> - Barcodes eliminate the possibility of human error. - Barcode reader is cheaper than RFID (3,000 Baht). 	<ul style="list-style-type: none"> - Barcode tags are easily damaged. - Not user-friendly. - Needs to use a barcode reader. - Can scan only one item at a time.
QR code	<ul style="list-style-type: none"> - Can use any camera to read QR code. - Cheaper than RFID (depend on the quality of the camera). 	<ul style="list-style-type: none"> - Tag is easily damaged. - Require a good quality camera. - Can scan only one item at a time.
BLE beacon	<ul style="list-style-type: none"> - Long-range: 70-450 m. - Energy saving. 	<ul style="list-style-type: none"> - Tag has a battery. - Tag can be turned off.

2.2.2 Processing device

The method of processing devices describes each processing device that used in this system.

- **Arduino Uno** is a microcontroller board that uses the ATmega328P microcontroller and also have analog pins and digital pins. It is used for receiving data from the UHF reader to send the data to Raspberry Pi via serial port [27].

- **Raspberry Pi 4** is a low-cost and small computer that can connect to a computer monitor and utilize a conventional keyboard and mouse. It is a capable small device to learn about computers and programming in languages such as Python. It is used for receiving data from Arduino Uno and inserting, updating, and deleting the data in the database including controlling all hardware [28].

2.2.3 Output device

The method of output devices represents each output device that is used in this system.

- **A magnetic solenoid** is a wire with numerous coils wrapped around an iron core that emits a magnet (single coiled wire wrapped around a metal core). It is intended to be used as a locked door locker [29].

- **A buzzer**, also known as a beeper, is an audio signaling system that is electronic, and electromechanical. Mostly used for timers and alarm clocks. It is used as an alarm when a user fails to close the door locker in time or when a user attempts to steal an item that has not yet been borrowed [30].

RFID is utilized in the CIEON Inventory Management System hardware portion to differentiate items taken from the locker by the user. It keeps track of the items in storage; therefore, it knows which ones have been taken. To lock doors, the structure will use a magnetic lock, a transmitter sensor, and an emitter sensor. As soon as the consumer removes the item, the door will close, and the maker sensor will be activated. The emitter sensor delivers a signal to the receiver sensor, which is connected to the opposite side of the corridor and activates the solenoid sensor, causing the door to spring open. Once RFID at the doorway detects an item that is not equivalent to the client input website, the alarm sensor is triggered, and the caution sensor alerts the user. During the first detection phase, the alarm sensor or buzzer sensor is also used. In condition, the user opens the locker door over the timer setting. Thus, the buzzer will go off to close the door and the buzzer will stop the alarm after closing the locker door.

This chapter described the overall design and overall structure of CIEON Inventory Management System. It starts with the method of front-end and back-end by describing tools that are used in order to make a website that tools use to communicate with database and authentication features. Moreover, it also describes the method of hardware separating into each method that is required in this system such as the method of detection.

CHAPTER 3: METHODOLOGY

3.1 Introduction

This chapter describes the design of CIEON Inventory Management System business model and the process of the system in every feature. First, the chapter describes the project's design business model by defining the pain point with customer insight, ideation, and objective of this system along with the business model canvas. It further explains the methodology of the system in architecture, use case, sequence diagram, and database design.

3.2 Design methodology

The CIEON Inventory Management System is based on the idea of putting together a system that allows users to perform self-borrowing and self-returning. In addition, the system determines how to detect what items have been taken. As a result, our project begins by investigating relevant equipment for identifying items and aiming to implement a user-friendly system. According to table 2.1, after considering all of the selections, we determine that RFID coupled with the alarm sensor, transmitter, and emitter sensor, is the best fit for this project. The other major notion is to make a user interface easy to use and understand.

The design and development of CIEON Inventory Management System are the following processes:

3.2.1 Overall system

According to figure 3.1, it presents the system architecture of the full system. The CIEON Inventory Management System separates into 2 main parts of online, and offline website, and has 2 types of users which are admin and teacher or student. There are different activities in both users' type. Firstly, the admin has 5 activities, and the teacher or student has 7 activities. The admin can add, edit, view, delete data online and also open the locker by using the local system. On the other hand, students and teachers cannot do any admin activity but they can borrow, return, reserve, and extend items along with declare broken items or lost items.

CIEON Inventory Management System uses host from HostNeverDie as well as the database. On the online website, as mentioned above, will have 12 features. All of the features interact by using PHP language to communicate with the database. The offline website also interacts with databases by using PHP language and it will communicate with hardware device by using JSON language. Raspberry Pi uses post and get method to send and receive the data. Arduino Uno acts as an offline receiver which keeps getting RFID tags data from the RFID reader and then send those data to the Raspberry Pi which posts, updates and inserts those data to the database.

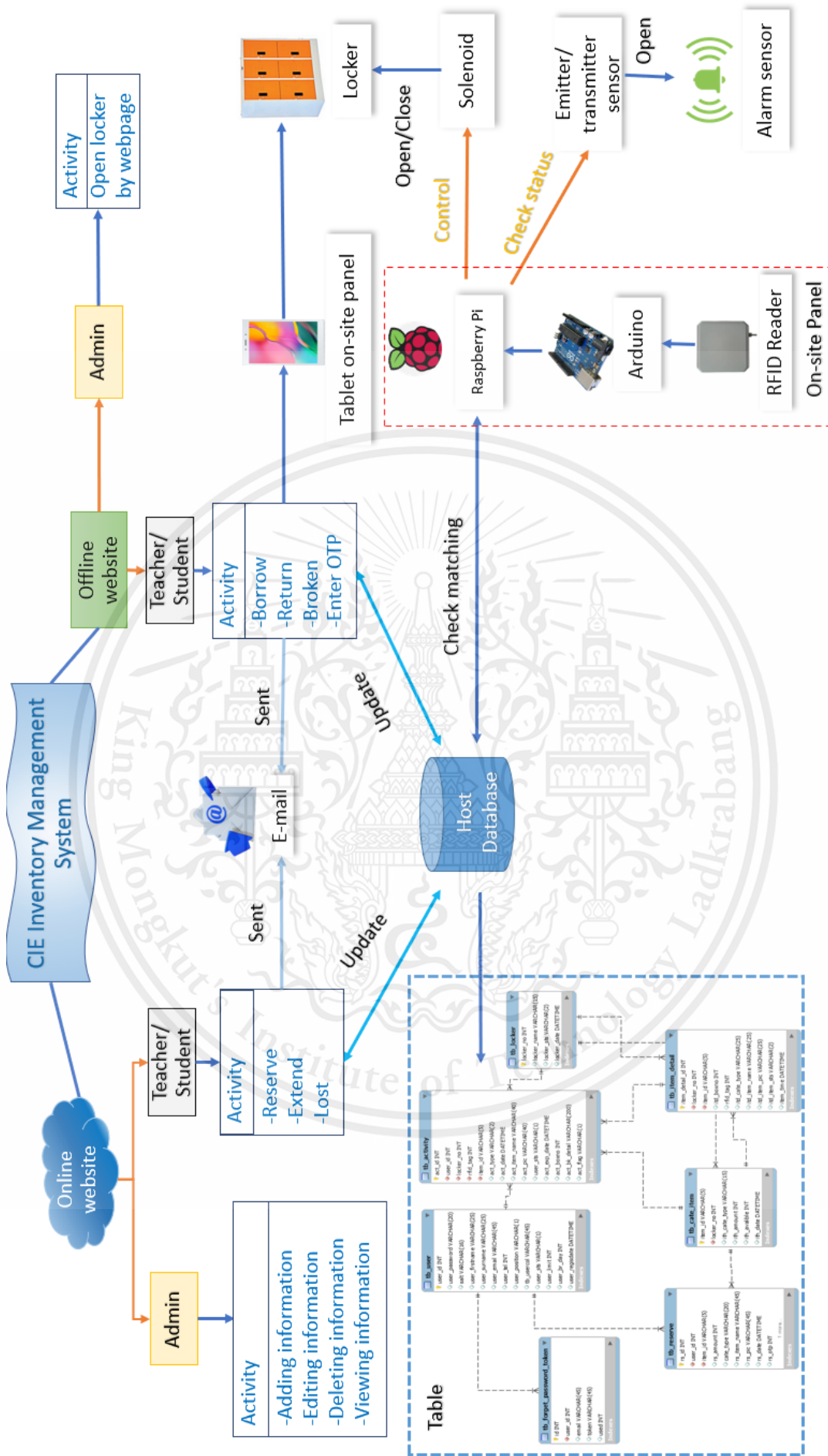

Figure 3.1 Architecture of full system

3.2.2 Hardware system

Hardware system divides into two parts, which are the hardware operation and hardware state. Each part explains the process with the picture.

3.2.2.1 The hardware operation

The hardware process begins by scanning the item attached to the tag with the UHF reader. UHF reader detects the tag, and it will send the tag information to Arduino Uno connected by Wiegand port. Since the Arduino Uno receives the tag information, it will print the information of the tag in serial monitor into base 10 numbers. The Arduino Uno is connected to the Raspberry Pi by serial port to allow the Raspberry Pi to take the data of the tag printed on the serial monitor as the data used in INSERT / UPDATE / SELECT * FROM WHERE in database. At the same time, the Raspberry Pi controls the solenoid via connection to the 12V relay and control it using the GPIO pin, as well as the buzzer and door sensor segments, it is connected and controlled by the GPIO pin as well as shown in figure 3.2.

3.2.2.2 Hardware state

- **State 1:** UHF reader to Arduino Uno
 - UHF reader connects to Arduino Uno using Wiegand port. After the UHF reader can detect the tag, Arduino Uno will serial print in the serial monitor.
- **State 2:** Arduino Uno to Raspberry Pi
 - Arduino Uno connected to the Raspberry Pi using serial cable. Therefore, the Raspberry Pi will take the tag value that Arduino Uno prints on the serial monitor to be used to find in the database.
- **State 3:** Raspberry Pi to relay and relay connect to each solenoid
 - Raspberry Pi is connected to a 12V relay and a 12V relay is connected to a solenoid by a pin and a GPIO is used to control the solenoid.
- **State 4:** Raspberry Pi to the door sensor
 - The Raspberry Pi connects to the door sensor by a pin and uses the GPIO to control the door sensor.
- **State 5:** Raspberry Pi to buzzer
 - The Raspberry Pi is connected to the buzzer by a pin. It uses GPIO to control the ON / OFF operation.
- **Raspberry Pi to database**
 - The Raspberry Pi uses the tag from the Arduino Uno's serial to use it to INSERT / UPDATE / SELECT FROM WHERE FROM database.

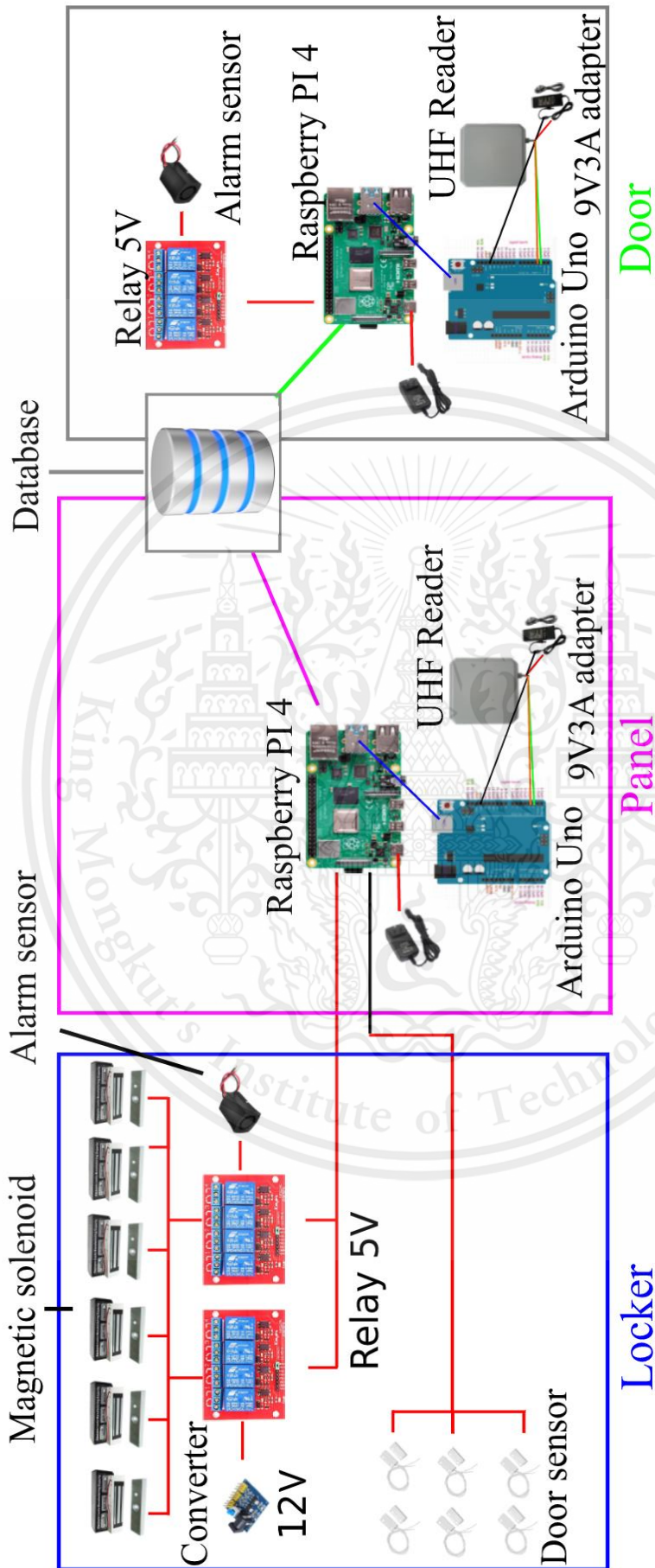

Figure 3.2 Architecture of hardware system

3.2.3 Architecture of software

The architecture of software explains the method of each feature process step by step with the picture to help the explanation.

- **Authentication**

Figure 3.3 shows the system architecture of authentication method by using phpMyAdmin. The login architecture starts by the user typing their email and password, the system will then send respond result to phpMyAdmin and verify the user's authentication. Then it will respond login success and allow the user access to homepage.

- **Reservation feature**

Figure 3.4 shows the system architecture of the reservation method by using phpMyAdmin. Reserve architecture starts by the user logging in and selecting the reservation feature then selecting the item along with the amount. The system will update the order information into the reservation cart. After the user clicks the reservation cart, the system will show their order list, store that information into database, bring the user to the conclusion page, and send the OTP number to the user's email then it will automatically logout.

- **Borrow feature**

Figure 3.5 shows the system architecture of borrow method by using phpMyAdmin. Borrow architecture starts by the user logging in and selecting the borrow feature then selecting the item along with the amount. The system will update the order information into the borrow cart. After the user clicks borrow cart, the system will show their order list, store that information into database, bring the user to the conclusion page, and send the list of order to the user's email then it will automatically logout.

Moreover, the locker door will open according to the item that the user chooses, then the system will start counting down for 30 seconds and it will check if the door sensor is closed or not. If not, then it will trigger the alarm sensor, but if the door sensor detects that it is closed, the user must bring the items to scan with RFID reader. After the user scans the items with RFID reader, the Arduino Uno will receive RFID tag data and then send those data to Raspberry Pi and Raspberry Pi will update those data to the database.

- **Lost feature**

Figure 3.6 shows the system architecture of the lost method by using phpMyAdmin. Lost architecture starts by the user logging in, selecting the lost feature and selecting lost item, then the system will update the lost data to the database and automatically logout.

- **Return feature**

Figure 3.7 shows the system architecture of return method by using phpMyAdmin. Return architecture starts by the user logging in, selecting the return feature and selecting the items that the user wants to return. The system will automatically logout then the user brings those items to scan with the RFID reader. After the user scans items with the RFID reader, the Arduino Uno will receive RFID tag data and compare those data with the database. If it is correct, then the locker door will open. In addition, the locker door which is used for return only will open, then the system will start counting down for 30 seconds and it will check if the door sensor is closed or not. If not, then it will trigger the alarm sensor.

- **Broken feature**

Figure 3.8 shows the system architecture of the broken method by using phpMyAdmin. Broken architecture starts by user login, select broken feature and select broken items. The system will automatically logout then the user brings those items to scan with RFID reader. After the user scans items with the RFID reader, the Arduino Uno will receive RFID tag data and compare those data with the database. If it is correct, then the locker door will open. In addition, the locker door which is used for return only will open, then the system will start counting down for 30 seconds and it will check if the door sensor is closed or not. If not, then it will trigger the alarm sensor.

- **Extend date/time feature**

Figure 3.9 shows the system architecture of extending the date/time method by using phpMyAdmin. Extend date/time architecture starts by the user logging in, selecting extend feature, and selecting the item which they want to extend, then the system will update the new extended date data to the database and automatically logout.

- **Enter OTP feature**

Figure 3.10 shows the system architecture of the enter OTP method by using phpMyAdmin. Enter OTP architecture starts by the user logging in and selecting enter OTP feature, then using the OTP number from their email to fill in to enter on the OTP page. The system will show the reserve order on the conclusion page. After the user clicks the submit button, the system will update those data to the database and automatically logout. Moreover, the locker door will open according to the item that the user chose, then the system will start counting down for 30 seconds and it will check if the door sensor is closed or not. If not, then it will trigger the alarm sensor but if the door sensor detects that it is closed, the user must bring the items to scan with the RFID reader. After the user scans the items with RFID reader, the Arduino Uno will receive RFID tag data and then send those data to Raspberry Pi and Raspberry Pi will update those data to the database.

- **Controlling locker feature**

Figure 3.11 shows the system architecture of the admin control locker to be opened. The control locker architecture starts by the admin logging in and choosing the control locker page, then choosing the locker that the admin needs to open. The system will update the new locker status to the database. Raspberry Pi will receive new data from the database and control relay to open the chosen locker.

- **Admin adds item**

Figure 3.12 shows the system architecture of admin adds item. Adding item architecture starts by the admin logging in, choosing add item feature, typing new item information and saving those data then scan new items with the RFID reader. The system will insert that new information to the database.

- **Admin feature**

Figure 3.13 shows the system architecture of the admin features that can add, edit, view, and delete data. admin features consist of add, edit, view, and delete data which the admin can use to manage the data from the database. Admin feature architecture starts by the admin logging in and choosing the view data feature. To add data, the admin chooses add feature then fill in new information and the system will insert those data to the database. To edit data, the admin chooses edit data then edit each data, click the save button and the system will update the new information into the database. To delete data, the admin clicks the bin button on the data the admin wants to delete and confirm. The system will delete that data from the database.

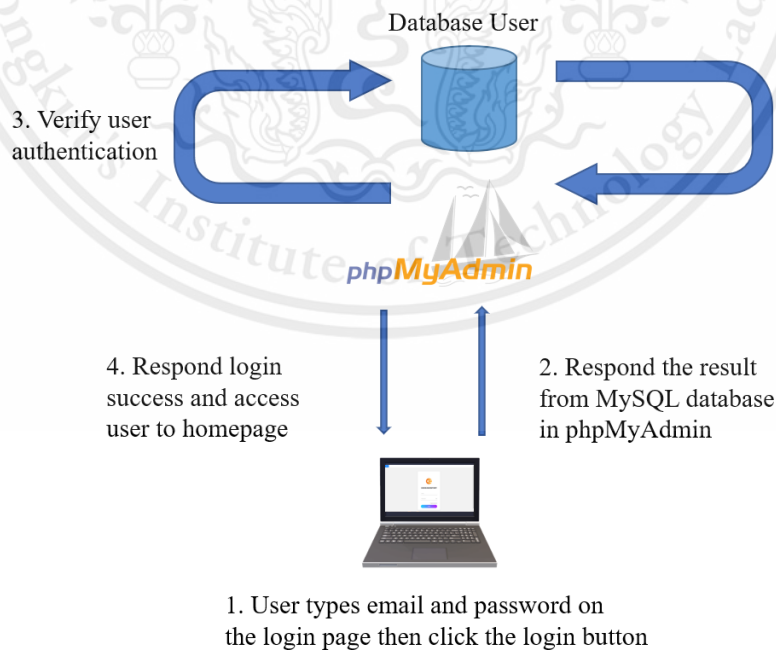

Figure 3.3 Architecture of login by using phpMyAdmin

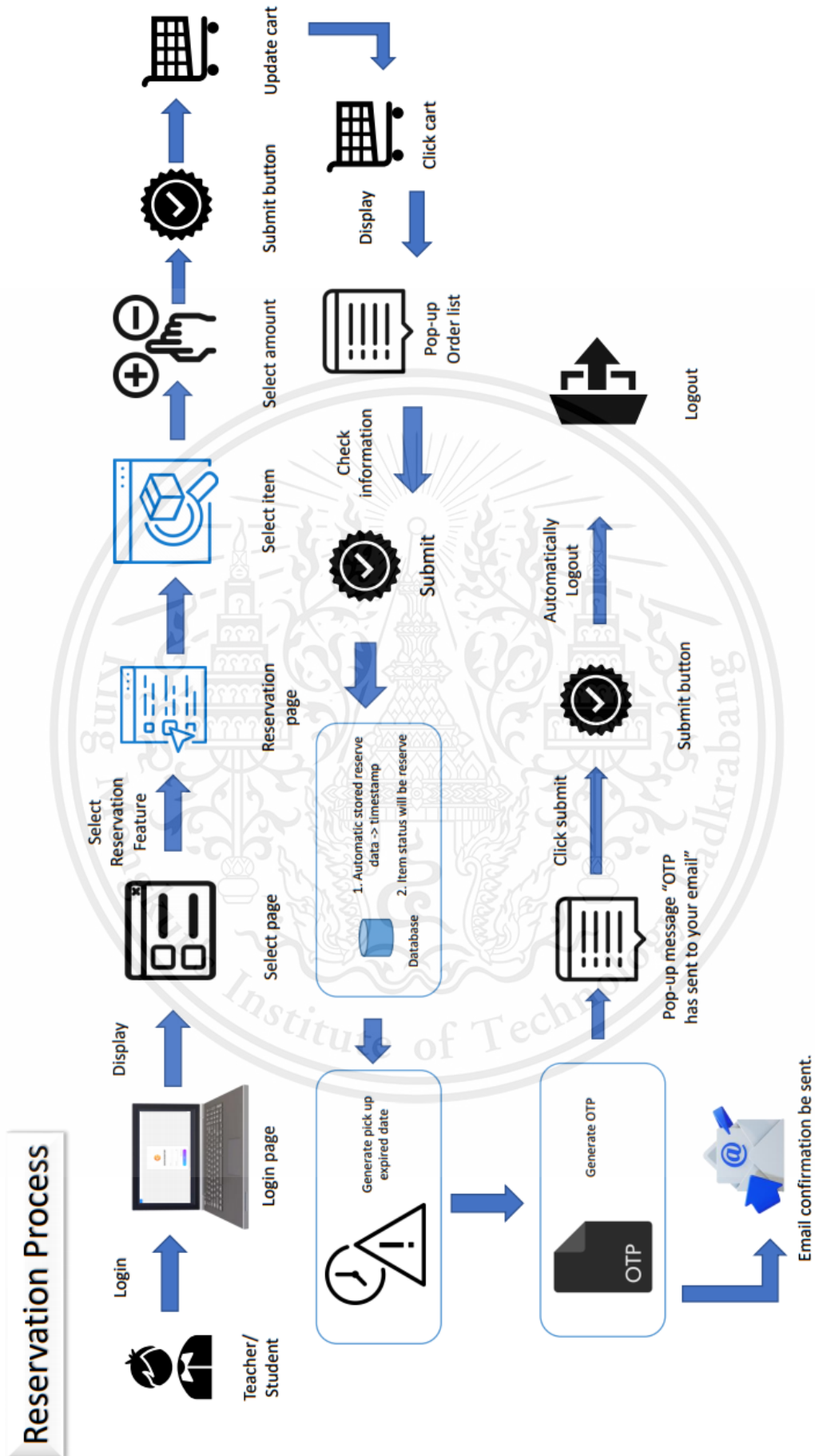

Figure 3.4 Architecture of reservation feature

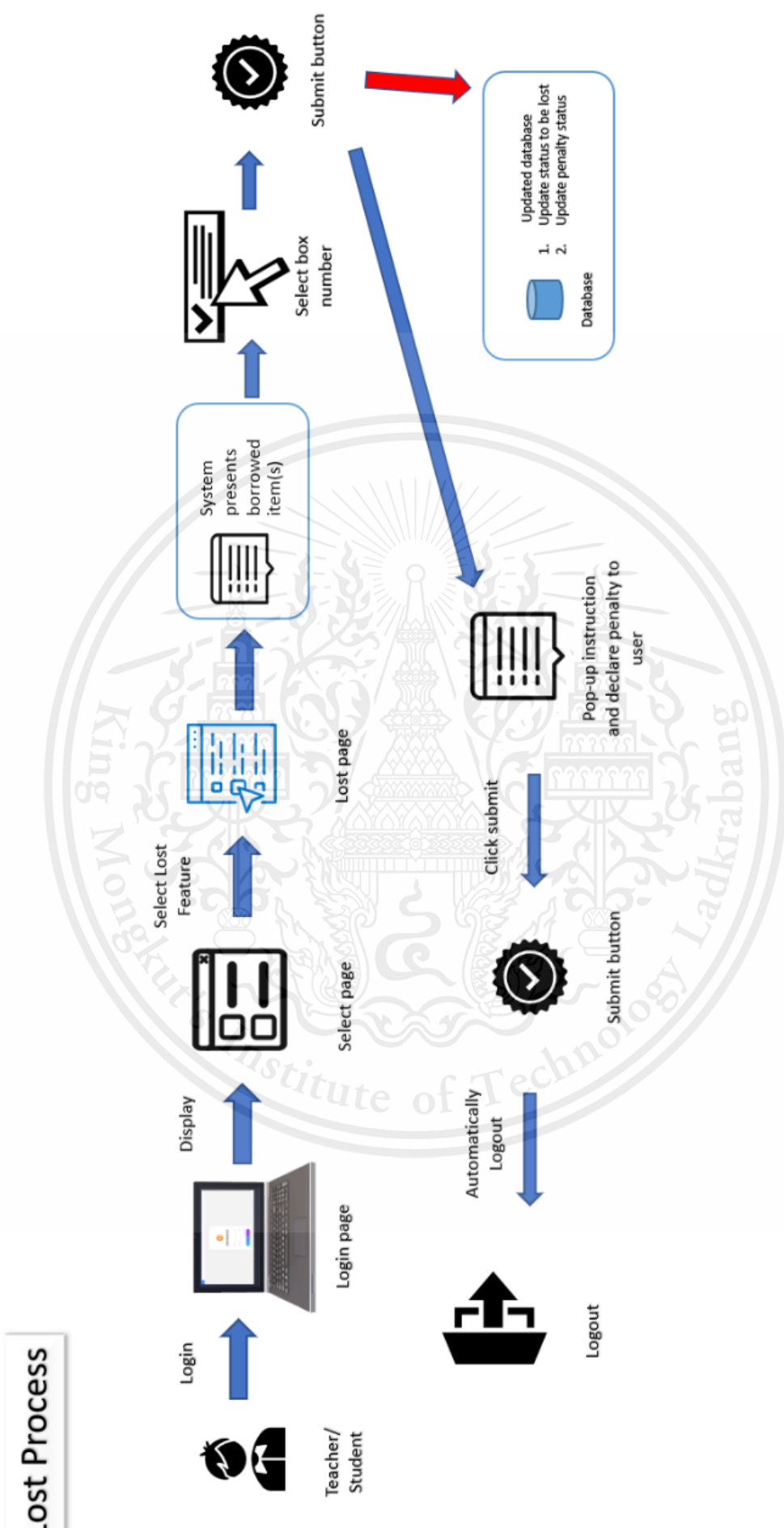

Figure 3.6 Architecture of lost feature

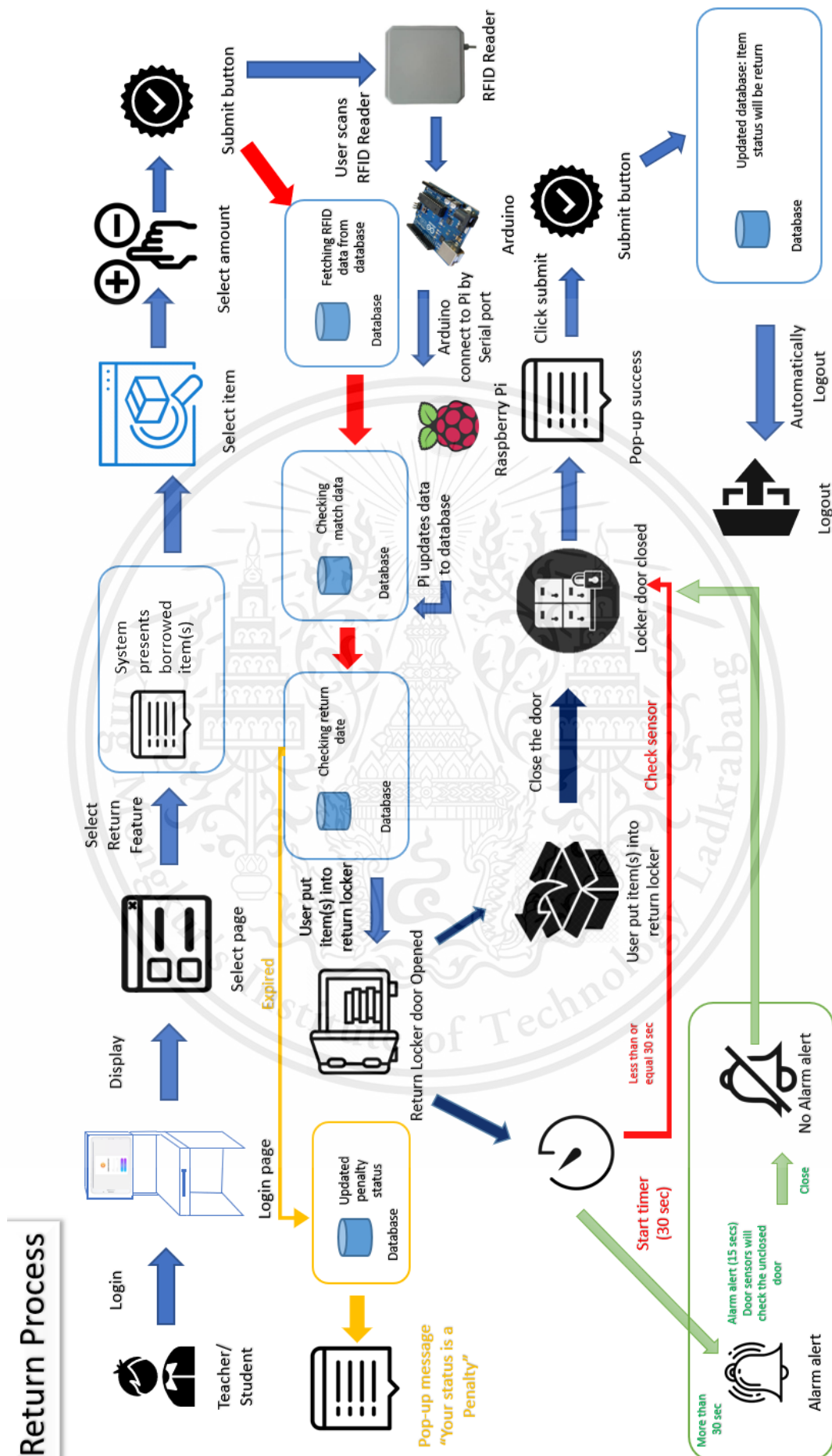

Figure 3.7 Architecture of return feature

This material is reserved for educational use only, not allowed for commercial use.

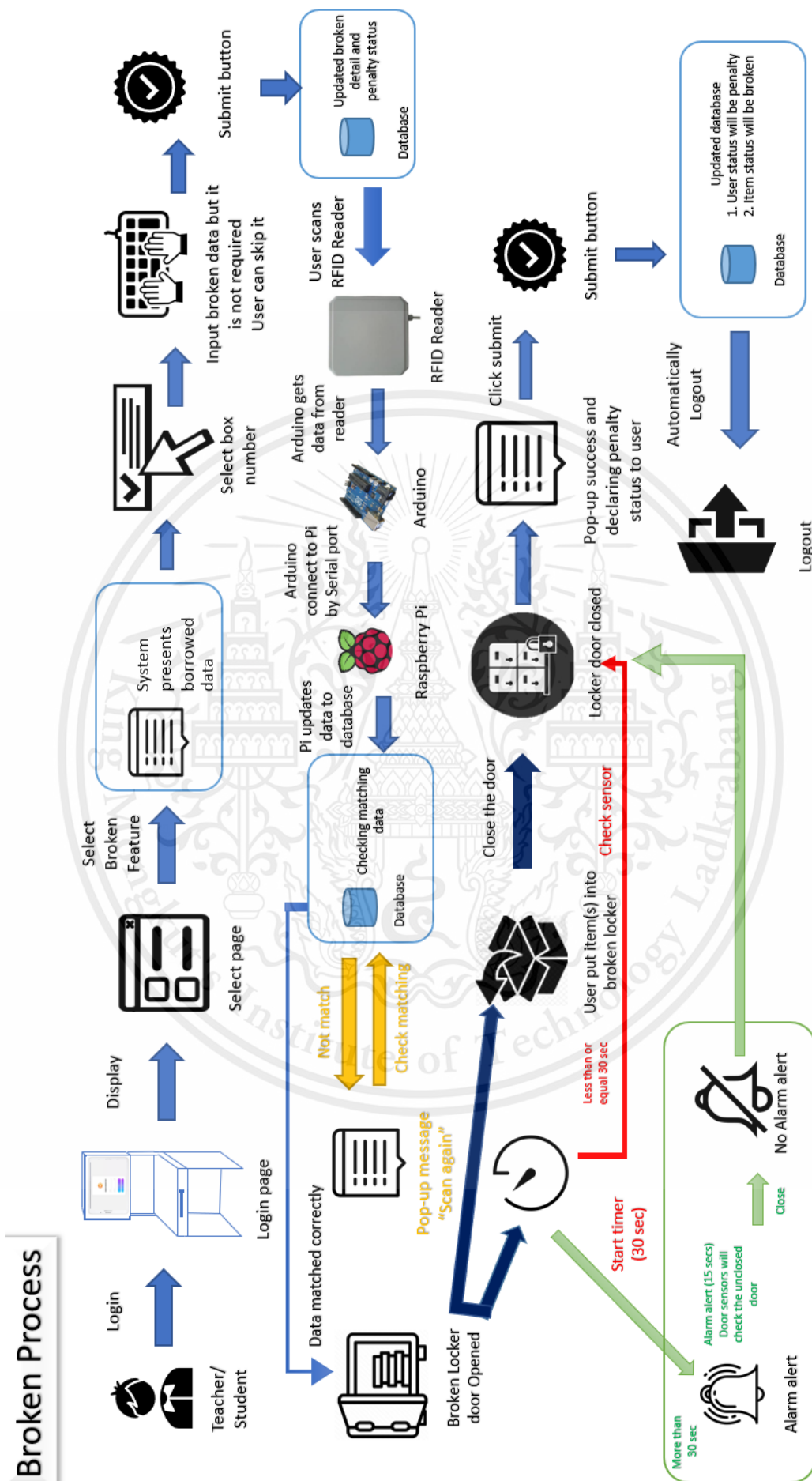

Figure 3.8 Architecture of broken feature

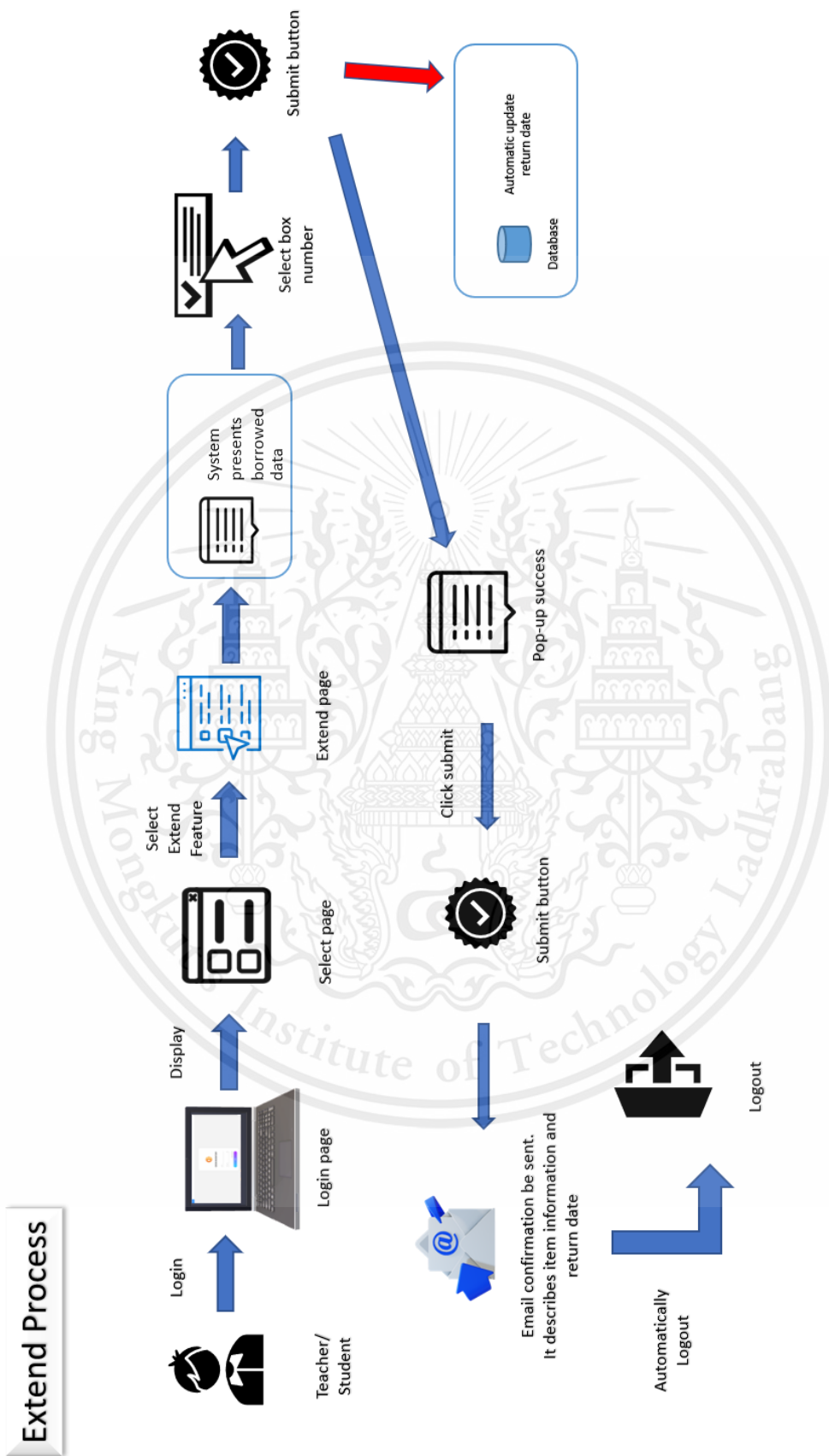

Figure 3.9 Architecture of extend date/time feature

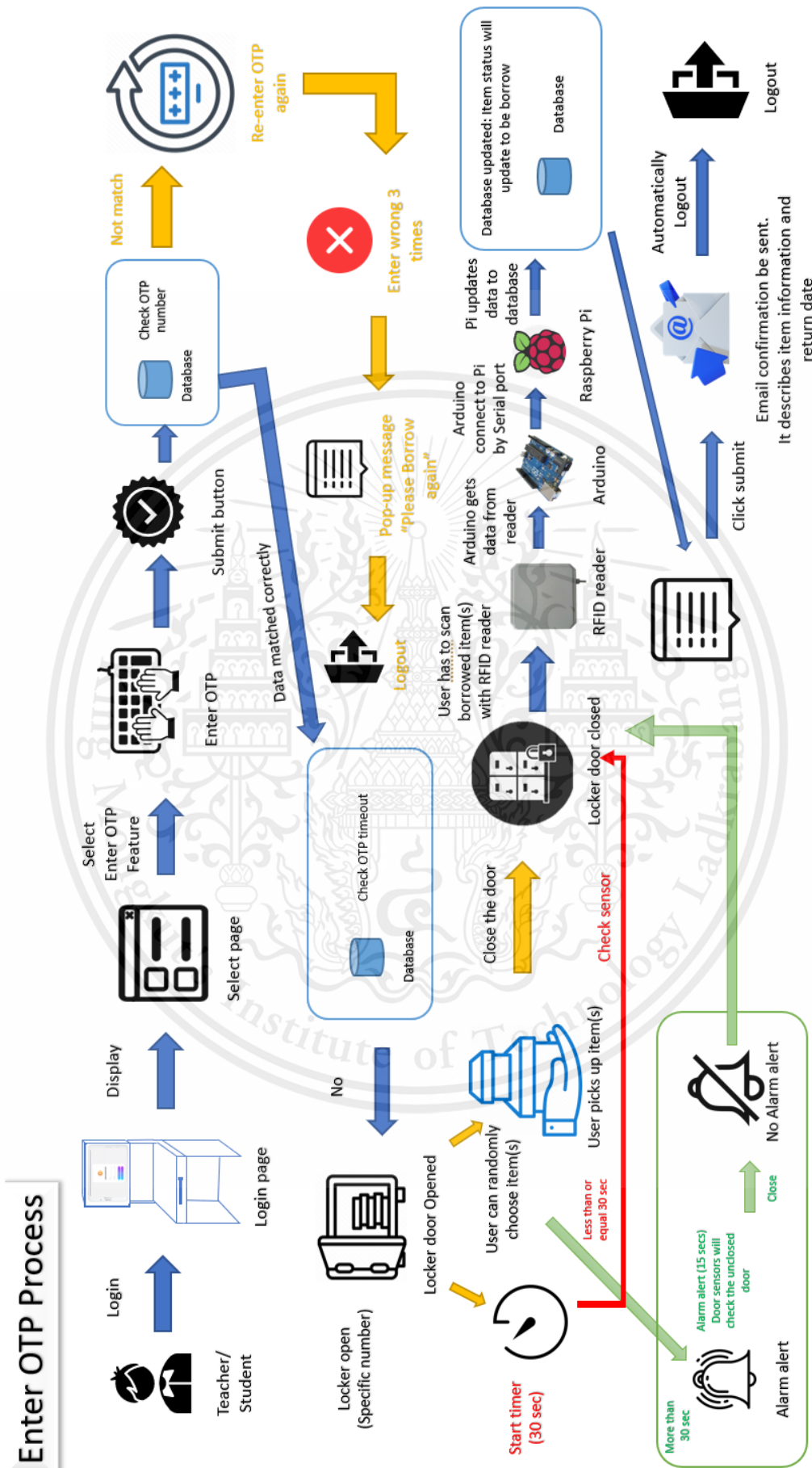

Figure 3.10. Architecture of enter OTP feature

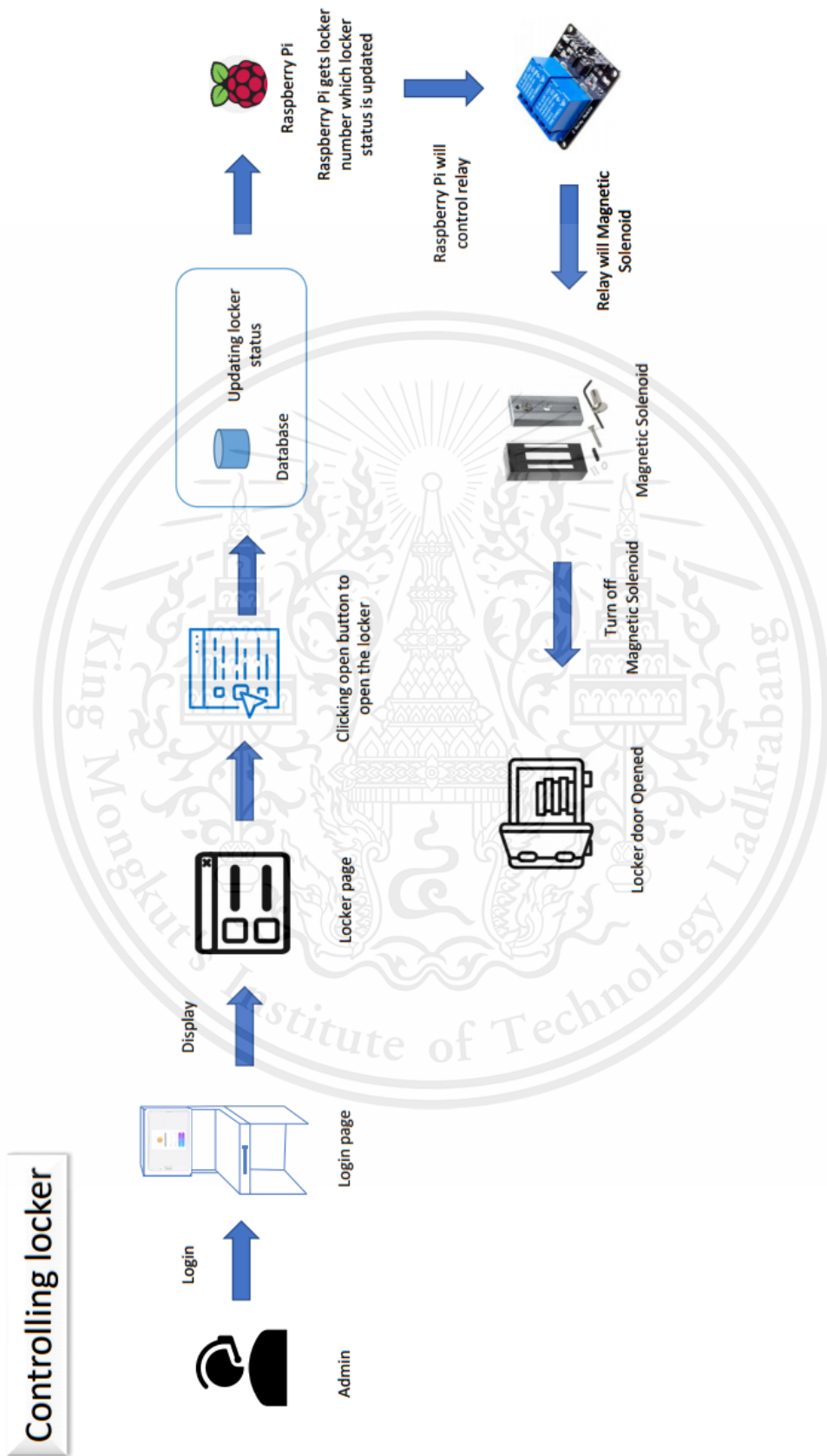

Figure 3.11 Architecture of controlling locker feature

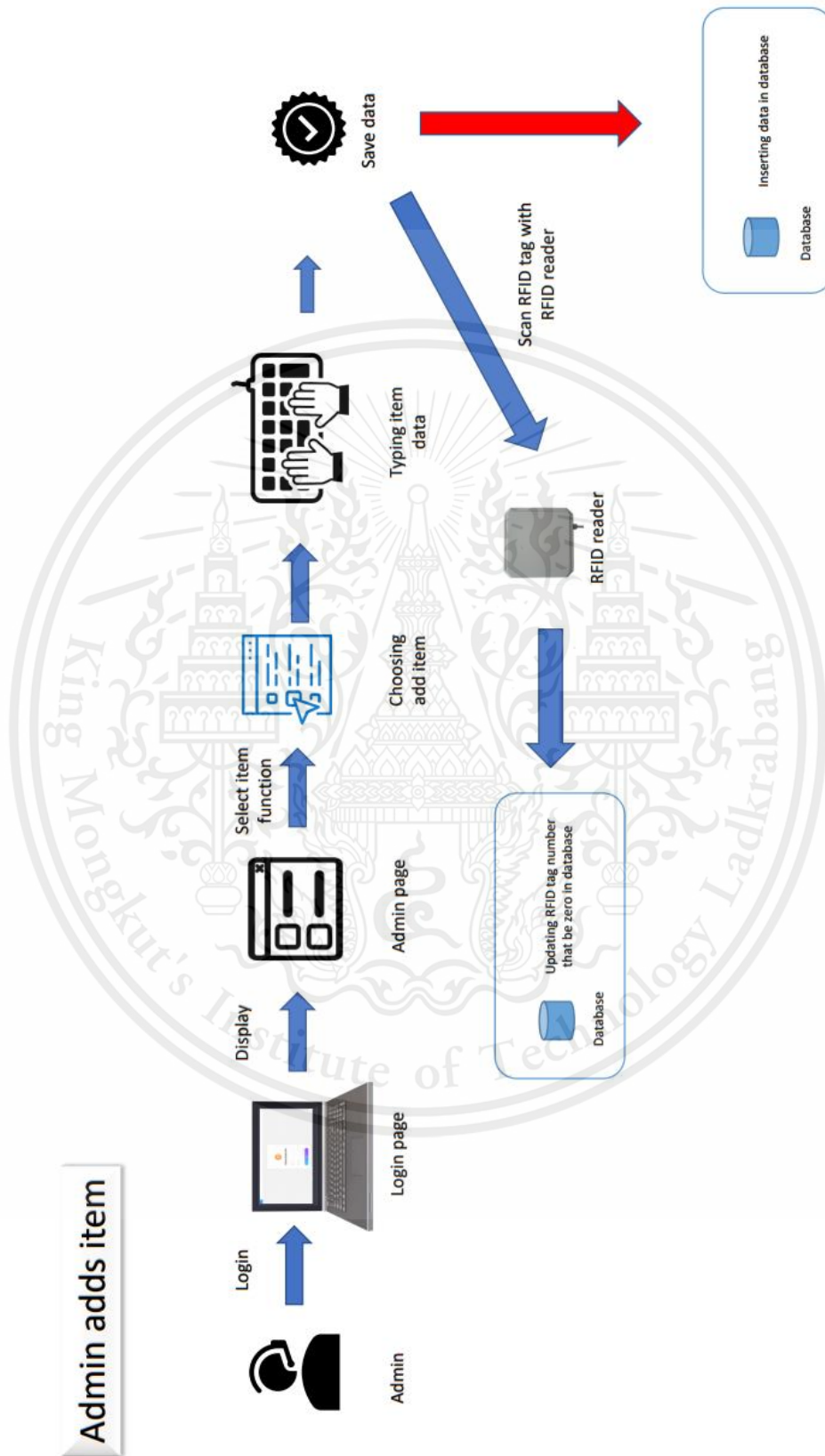

Figure 3.12 Architecture of admin adds item

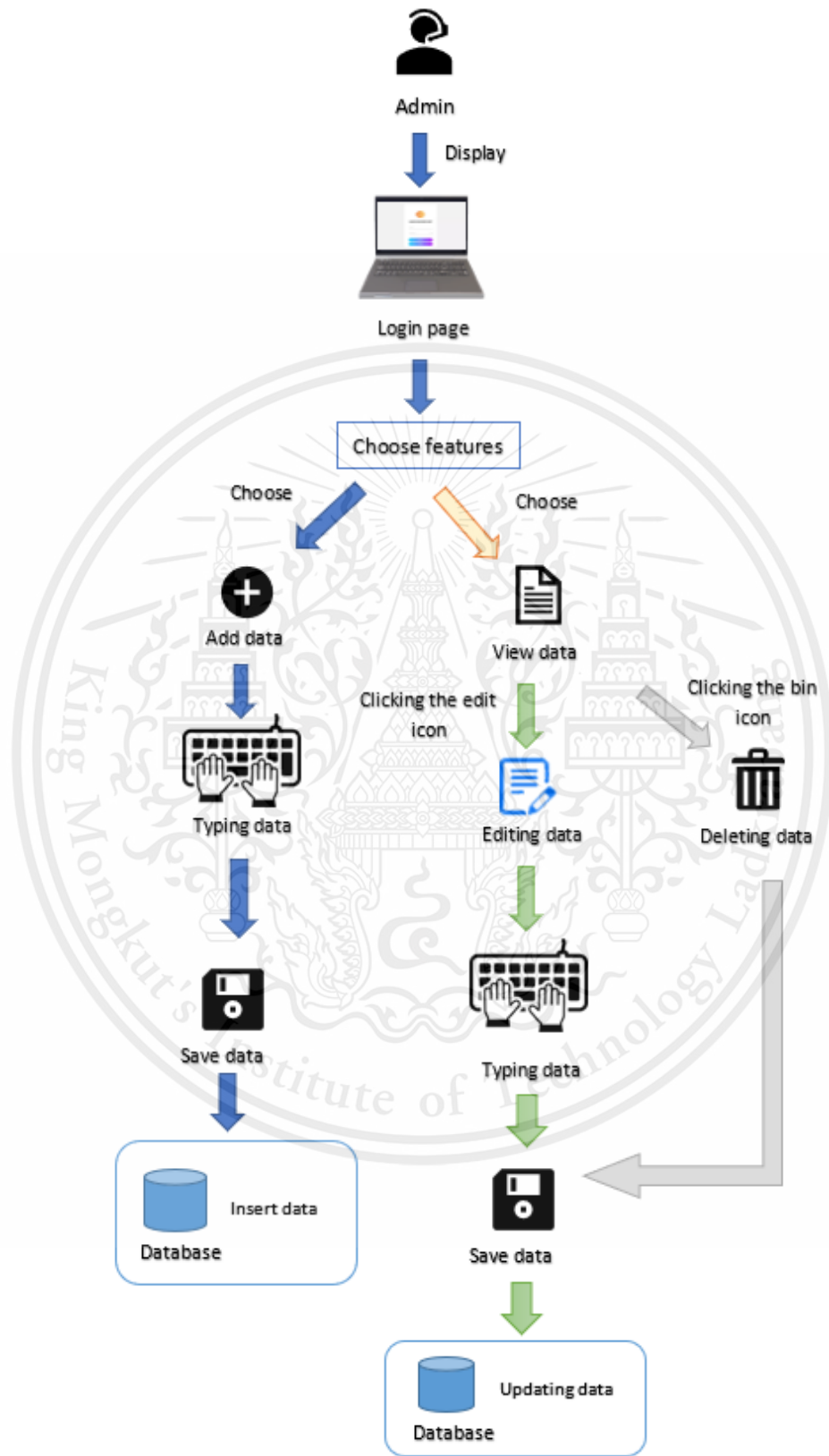

Figure 3.13 Architecture of admin feature

This material is reserved for educational use only, not allowed for commercial use.

3.3 System development

The system development illustrates the use case diagram and sequence diagram of this system with the explanation and picture of diagrams.

3.3.1 Use case diagram

Before developers construct the system, they must define the system's features. The use case diagram is the following step once we finish our concept. It is a strategy for comparing one diagram to another, and it requires additional data to depict the user's activity. To make it easier to understand and manage, each use case should be created on different types of users.

Figure 3.14 presents the use case diagram of students and teachers demonstrating the range of features available on the website. Using the authentication technique, both teachers and students can login and logout. Furthermore, they can utilize these following features: forget password, register, edit profile, reserve, enter OTP, extend, return, broken, lost, and borrow. After the user registers to the system, that user can do an authentication. In addition, reserve features will generate OTP and will be included in the enter OTP feature.

According to figure 3.15, it presents the use case diagram of the admin. The admin can login and logout by using the authentication method. There are 5 main functions for admins: add data, view data, edit data, delete data, and controlling locker.

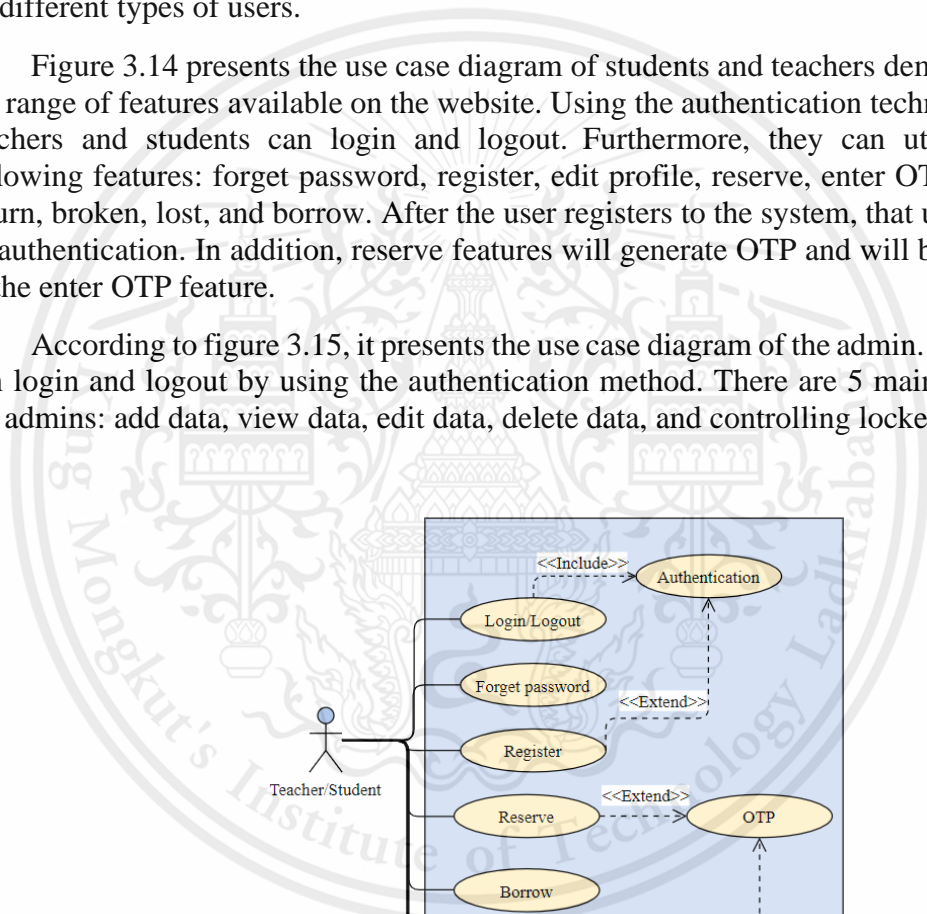

Figure 3.14 The use case diagram of a teacher and a student

This material is reserved for educational use only, not allowed for commercial use.

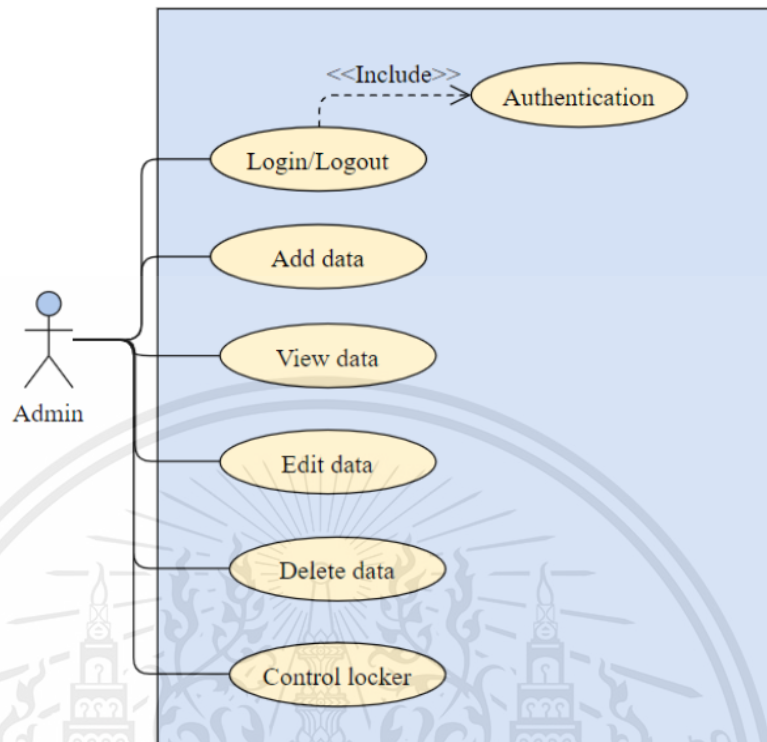

Figure 3.15 The use case diagram of an admin

3.3.2 Sequence diagram

The system cooperates in object-oriented analysis and design, as shown in the sequence diagram. The sequence diagram divides into two types from the use cases:

Teacher and Student:

- Authentication
- Registration
- Edit profile
- Forget password
- Reservation
- Borrow
- Enter OTP
- Extend date/time
- Return
- Broken
- Lost

Admin:

- Authentication
- Admin function
- Adding items
- Controlling locker

The sequence diagram of users in this system consists of the following sequences:

This material is reserved for educational use only, not allowed for commercial use.

- **Login**

When a user visits a website, the first page that appears is the login page, which needs the user to enter their username and password. If the login or password is incorrect, users will be unable to access the website. If the user successfully logs in, they will be directed to a different homepage based on their position as determined by the database's position information, as shown in figure 3.16.

- **Registration**

According to figure 3.17, after a new user enters the homepage. A new user has to click the register button on dropdown in the header webpage. Inside the registration page, the system will require users to fill in information. After the user finishes filling in information, the system will bring the user back to login page.

- **Edit profile**

According to figure 3.18, after authentication and enter to website, users can edit their profile by clicking the profile button on dropdown. Inside the profile page, users can edit all of the information that the system provides then save the information. The system will update the new data in the database.

- **Forget password**

According to figure 3.19, on the login page, it has the forget password button. When the user clicks the forget password button, the user has to type the exact email that they registered with then the system will send a confirmation email. For the user to confirm and change password, the user has to click the link inside the user's email and fill in a new password.

- **Reservation**

According to figure 3.20, the system's homepage will appear after the user has successfully logged in. The system will take the user to the reservation page if the user selects a reservation feature. The user can select the items, the quantity, and add them to their cart. The name, amount, and pick-up date of each item are summarized in the reservation cart. Items in the reserve cart can be adjudged by deleting them. A search engine is also available on the website to assist users in locating the required item. Finally, after pressing the confirm button, the website will send the user an OTP through email, and the system will log them out automatically.

- **Borrow**

According to figure 3.21, the website's homepage will appear after the user has successfully logged in. The system will lead the user to the borrow page if the user selects the borrow feature. The user can select items, amount, and add them to their shopping cart. The borrow cart displays a list of the objects with their names and quantities. The system will take the user to the conclusion page when they have exited the cart. In this page, users can adjudge items by deleting or repeating the choose item step again. Users can also utilize the website's search engine to find what they are

This material is reserved for educational use only, not allowed for commercial use.

looking for. After the user clicks the confirm button, the locker door will automatically open. When the locker door is opened, the timer will start and if the locker door opens for more than 30 seconds, the alarm will go off so the user has to close the door to stop the alarm. Users are required to put items on panel to scan RFID tags with the RFID reader then the website will send the order list to the user by email, and the system will automatically logout.

- **Return**

According to figure 3.22, after logging in successfully, the homepage will be displayed. The system will direct the user to the return page after selecting the return feature. All of the items that the user has already borrowed will be displayed on the return page. The user can choose to return an item by pressing the return button of that item then the return locker door will automatically open. When the locker door is opened, the timer will start. If the locker door opens for more than 30 seconds, the alarm will alert the user to close the door to stop the alarm. The system will pop up a message, “Do you want to proceed?” If yes, the user can continue to return the item but if no, the system will automatically logout.

- **Enter OTP**

Figure 3.23 presents the system successful login when the homepage will be displayed. Once choosing the enter OTP feature, the system will take the user to the enter OTP page. Inside the enter OTP page, the user can fill the OTP number which they received from the reservation. In the case that the OTP is correct, the user will be able to see a reserved item list that includes a summary of the reservation item consisting of the item name, quantity, pick-up date, and return date. After selecting the confirm button, the user can take the selected object. The system will command the locker door containing the chosen item to open. Once the locker door is opened, the timer will start. If the locker door opens for more than 30 seconds, the alarm will alert the user to close the door to stop the alarm. Lastly, the system will automatically logout.

- **Lost**

Figure 3.24 shows after logging into the system successfully, the homepage will be displayed. The website will take the user to the lost page when the user selects the lost feature button. The borrowed item lists are displayed on the lost page. In this feature, the user has to select a lost item by clicking the lost button near that item. After selected item, the system will pop up the message, “Do you want to proceed?” The system will automatically logout if the user chooses no. However, if the user chooses yes, the system will go back to the lost page. Lastly, the penalty alert will be shown to the user homepage.

- **Broken**

Figure 3.25 shows after logging in to the system successfully, the home page will be displayed. If the user selects the broken feature, the website will direct them to the broken page. The description of the items that the user borrowed, including the name and number of each item, is displayed on the broken page. Following the

user's selection of the broken item, the system will display an explanation box for the user to put in comments regarding the item's difficulties, as well as a choice to continue or logout. Either choice, the broken locker door will open, allowing the user to place the broken item inside. Once the locker door is opened, the timer will start. If the locker door opens for more than 30 seconds, the alarm will alert the user to close the door to stop the alarm. The system then automatically logs out. Lastly, the penalty alert will be shown on the user homepage.

- **Extend date/time**

According to figure 3.26, after logging in successfully, the homepage will be displayed. When the user chooses the extend date/time feature button, the website will take the user to the extend date/time page, which displays the borrowed item list. The user has to choose the item to extend the return date. After selecting extend item, the system will automatically logout.

- **Add data**

According to figure 3.27, the admin logs into the system then begins doing an authentication on the login page. Once the admin enters the website, the admin has to choose between the Add data and view data feature. In the case where the admin chooses to add data, the system will let the admin to type data then save the data. After that, the system will insert the new data into the database. Finally, the system will update the data that is edited or deleted in the database.

- **View data**

According to figure 3.28, the admin logs into the system then begins with doing an authentication on the login page. Once the admin enters the website, the admin has to choose feature between the add data and view data feature. In the case where the admin chooses to view data, the system will fetch the current data from the database and display the data.

- **Edit data**

According to figure 3.29, the admin logs into the system then begins with doing an authentication in the login page. Once the admin enters the website, the admin has to choose between the edit data or delete data feature. To edit data, the admin has to choose the edit icon and the current data will be displayed to let the admin edit the data. The system will update the new data in the database after the admin types and saves the data.

- **Delete data**

According to figure 3.30, the admin logs into the system then begins with doing an authentication in the login page. Once the admin enters the website, the admin has to choose between the edit data or delete data feature. To delete data, the admin has to click the bin icon. The system then will update data to the database.

- **Admin adds item**

According to figure 3.31, once the admin logs in to the system on the login page, the system will display the admin page. The admin has to select the item function and choose the add item feature to type the item's data then save the data. The system will insert the new data into the database. Furthermore, RFID tag number in the database is zero. The admin needs to scan RFID tag with the RFID reader to update new RFID tag numbers in the database.

- **Controlling locker**

According to figure 3.32, once the admin logs in to the system on the login page, the system will display the admin page. The admin can choose to open the locker door by clicking the open button. After that, the selected locker door will open, and the database will be updated from close to open. After the admin puts the items in or out, the admin needs to logout of the system.

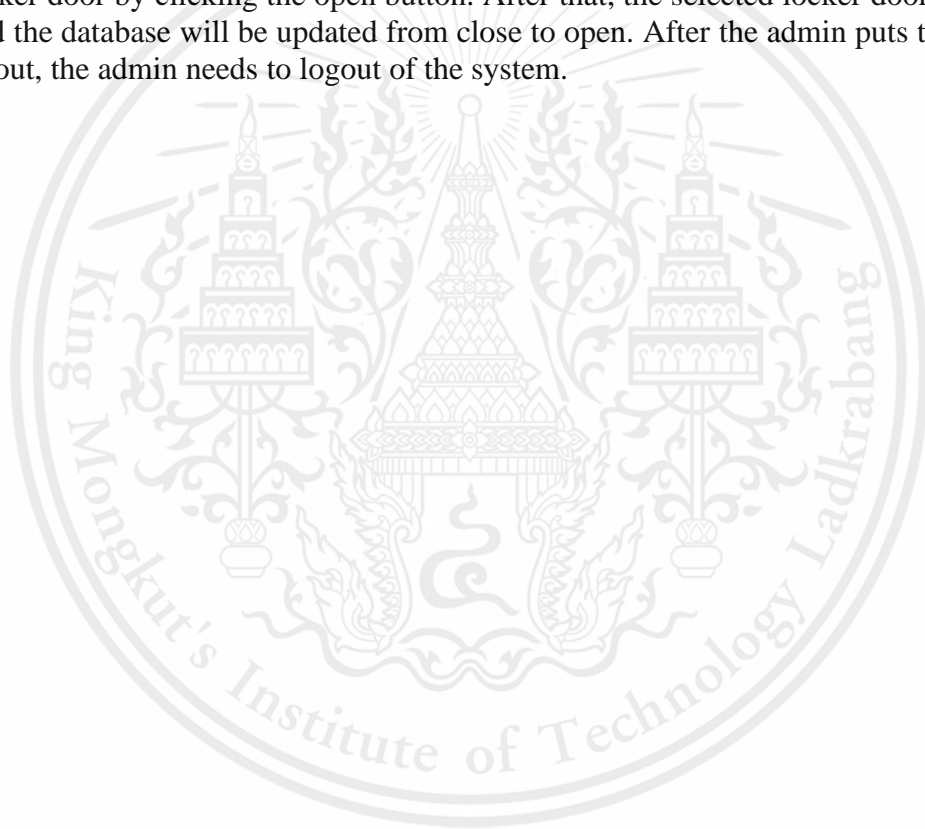

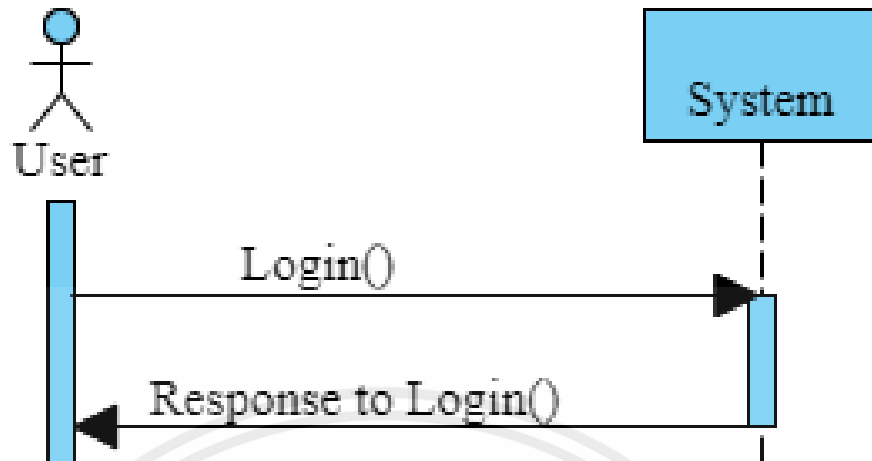

Figure 3.16 Diagram for user's login

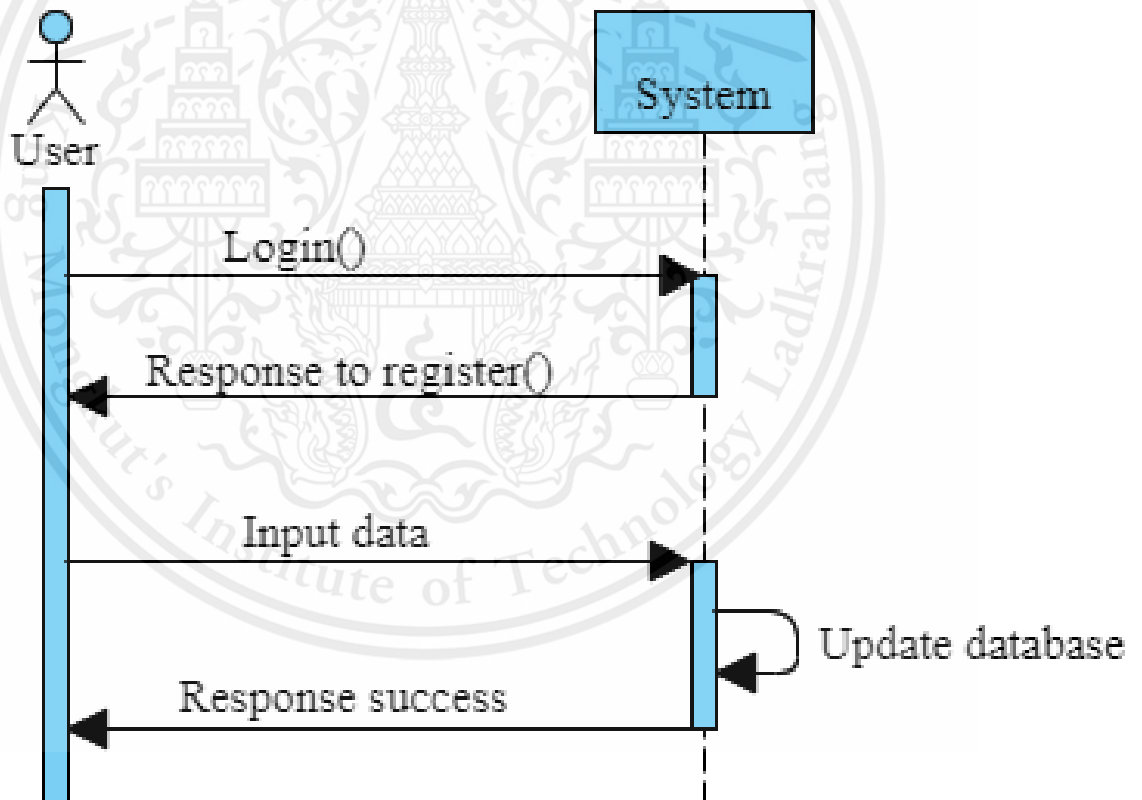

Figure 3.17 Diagram for user's registration

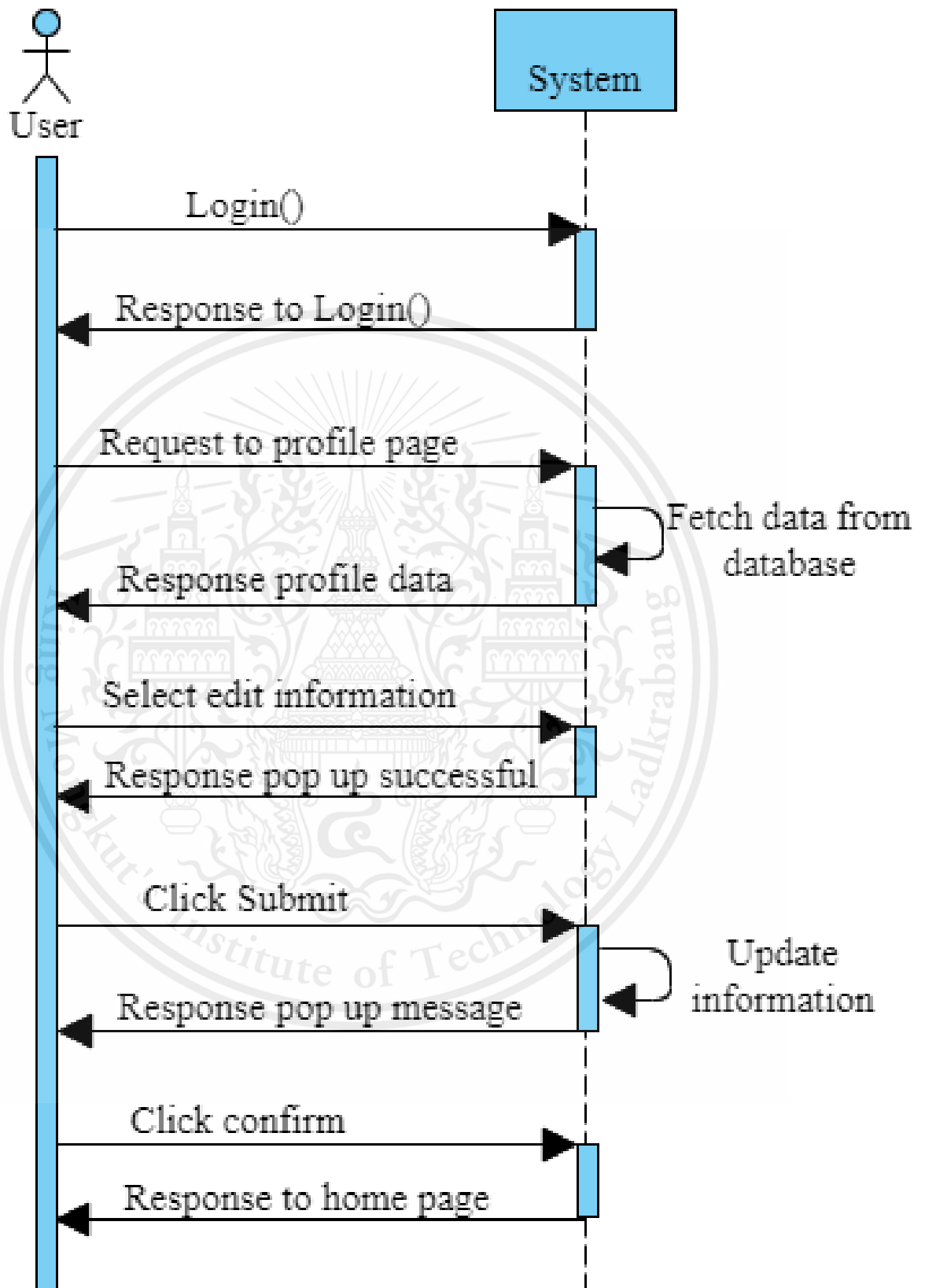

Figure 3.18 Diagram for user's edit profile feature

This material is reserved for educational use only, not allowed for commercial use.

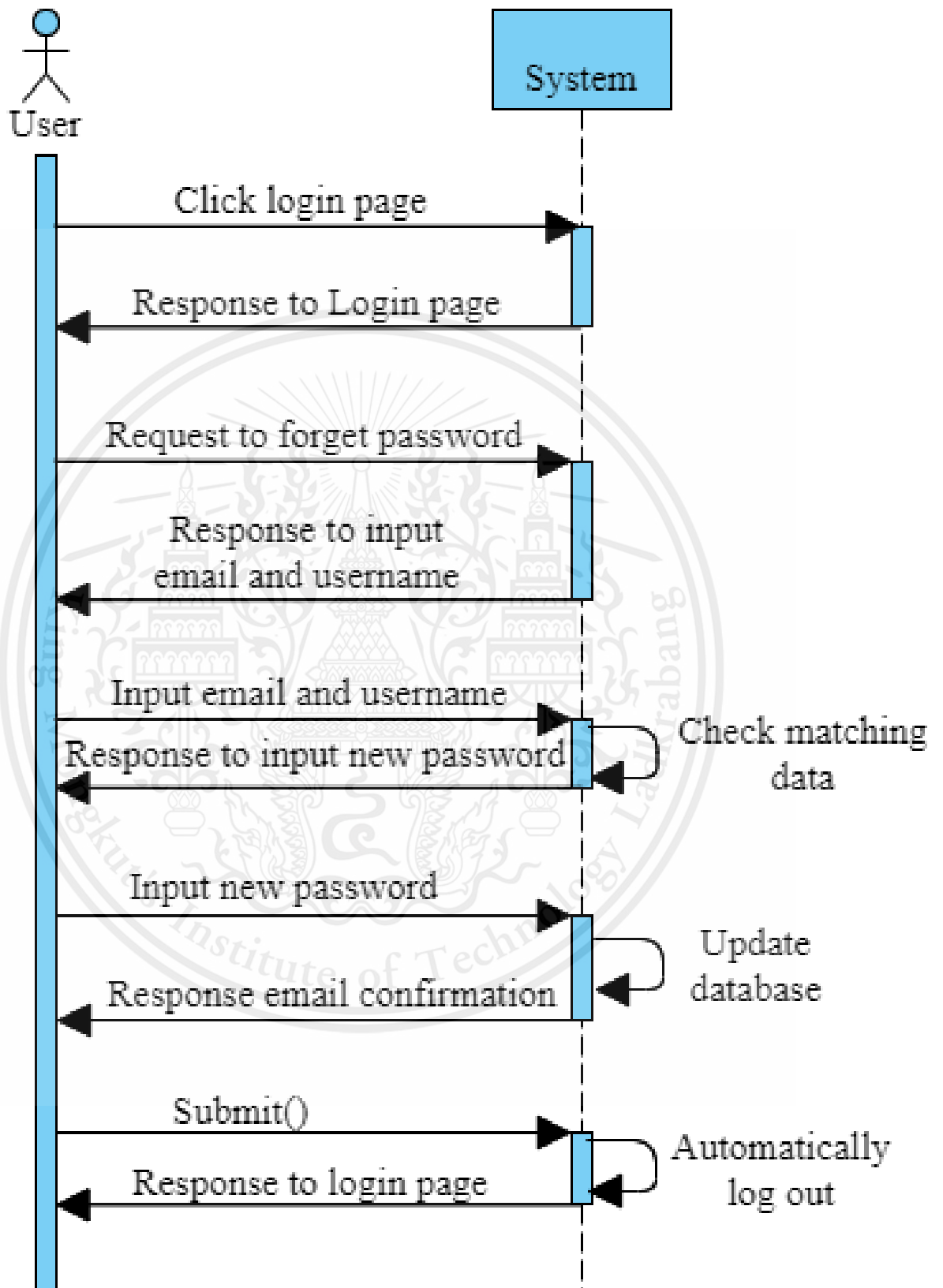

Figure 3.19 Diagram for user's forget password feature

This material is reserved for educational use only, not allowed for commercial use.

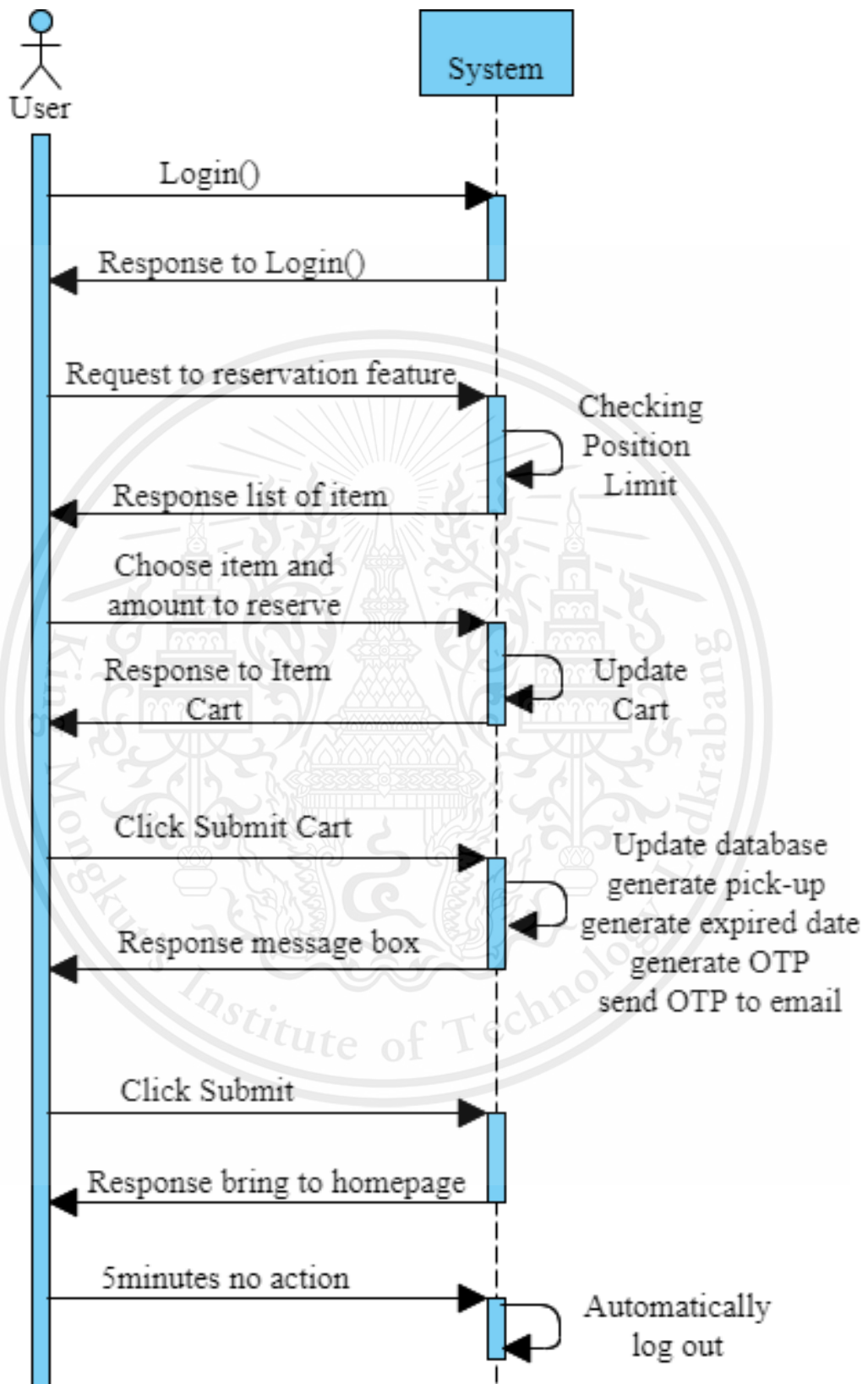

Figure 3.20 Diagram for user's reservation feature

This material is reserved for educational use only, not allowed for commercial use.

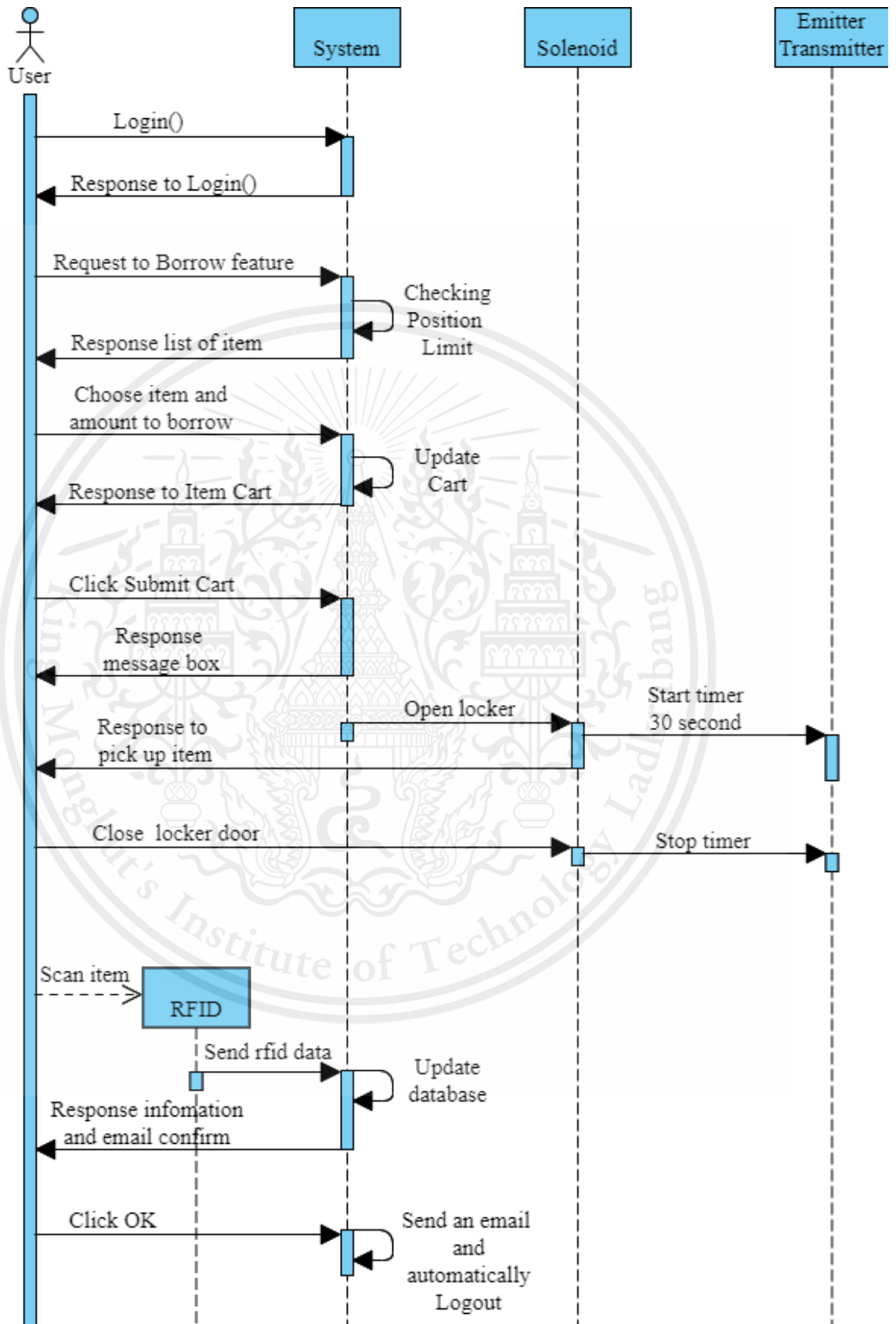

Figure 3.21 Diagram for user's borrow feature

This material is reserved for educational use only, not allowed for commercial use.

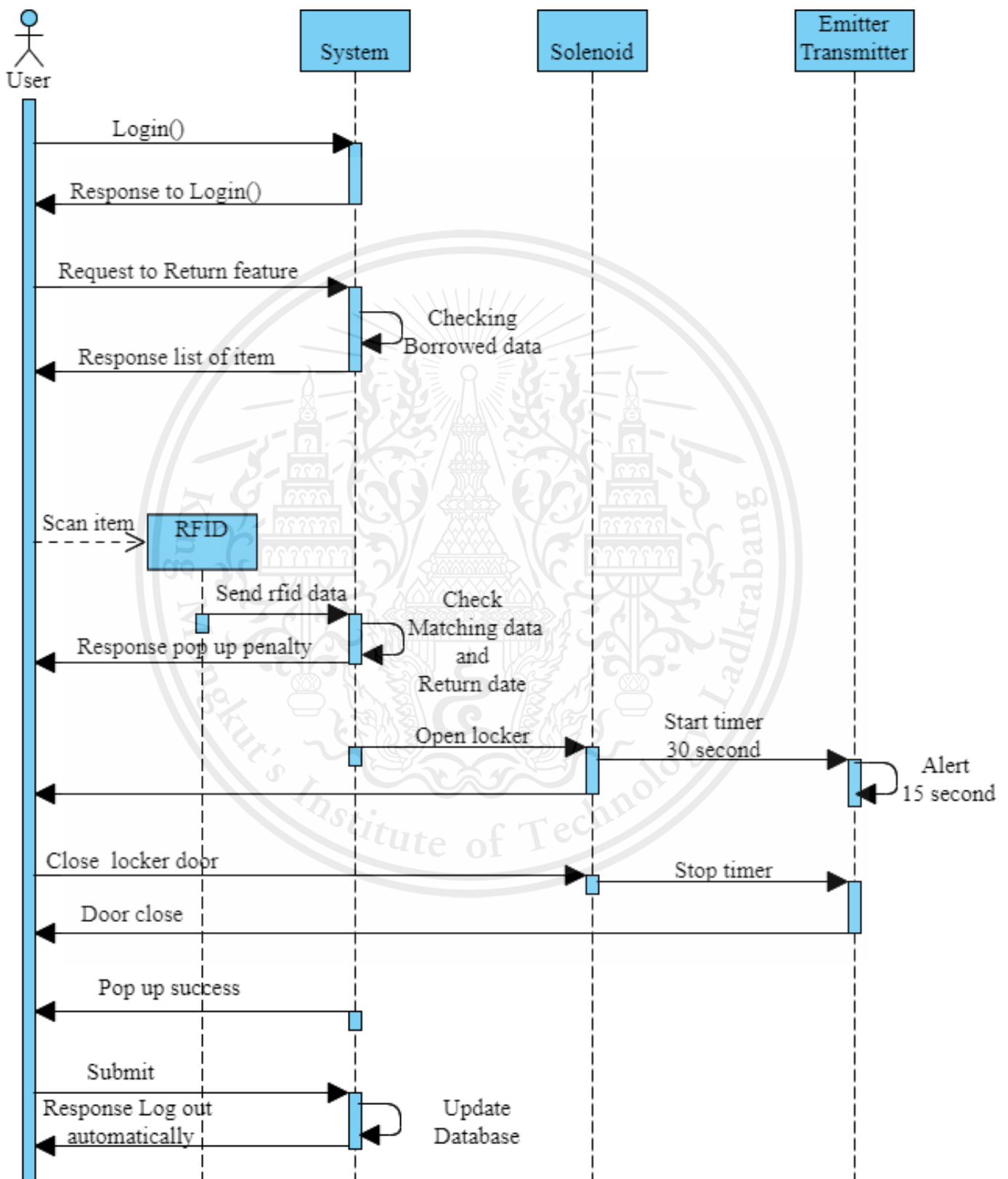

Figure 3.22 Diagram for user's return feature

This material is reserved for educational use only, not allowed for commercial use.

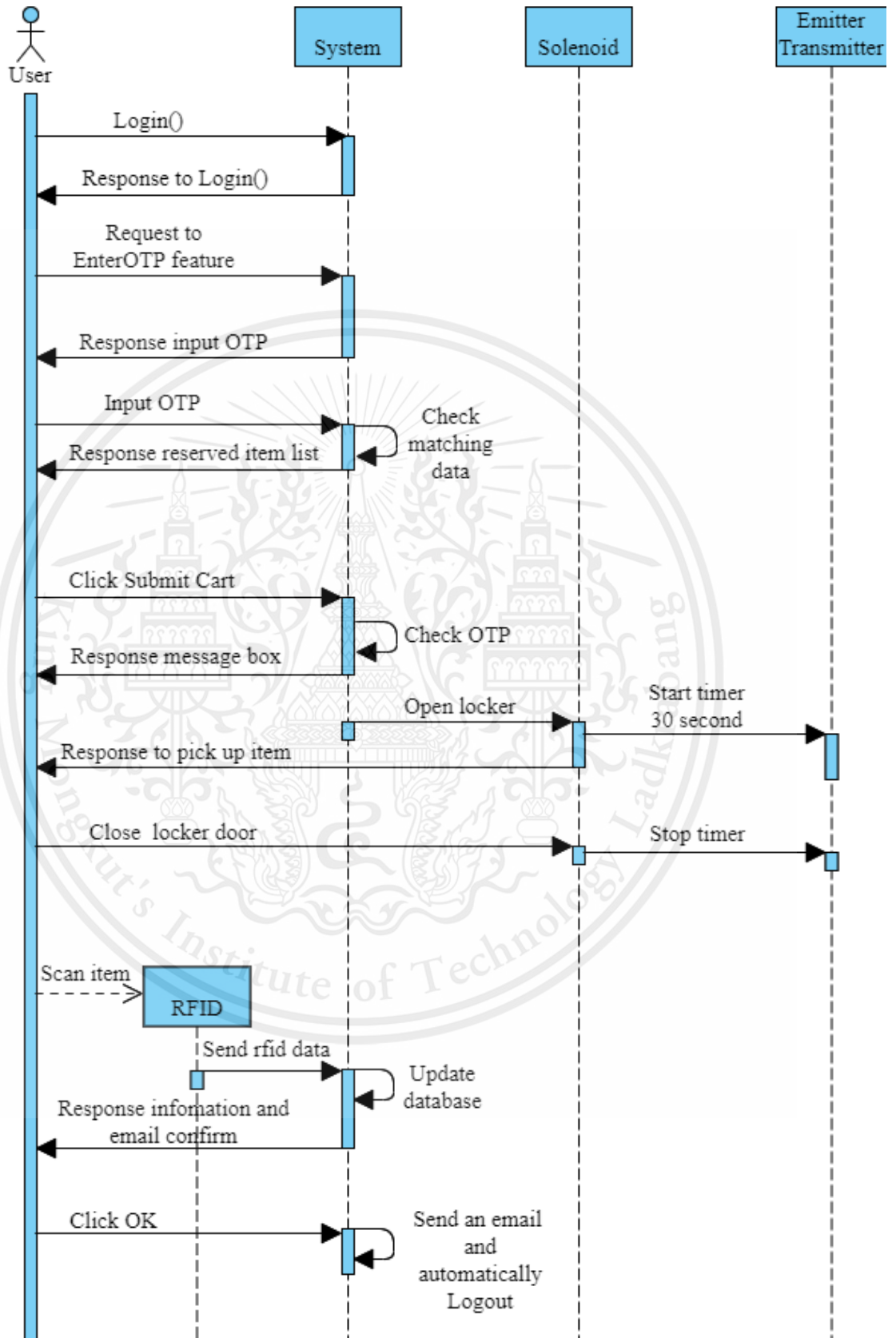

Figure 3.23 Diagram for user's enter OTP feature

This material is reserved for educational use only, not allowed for commercial use.

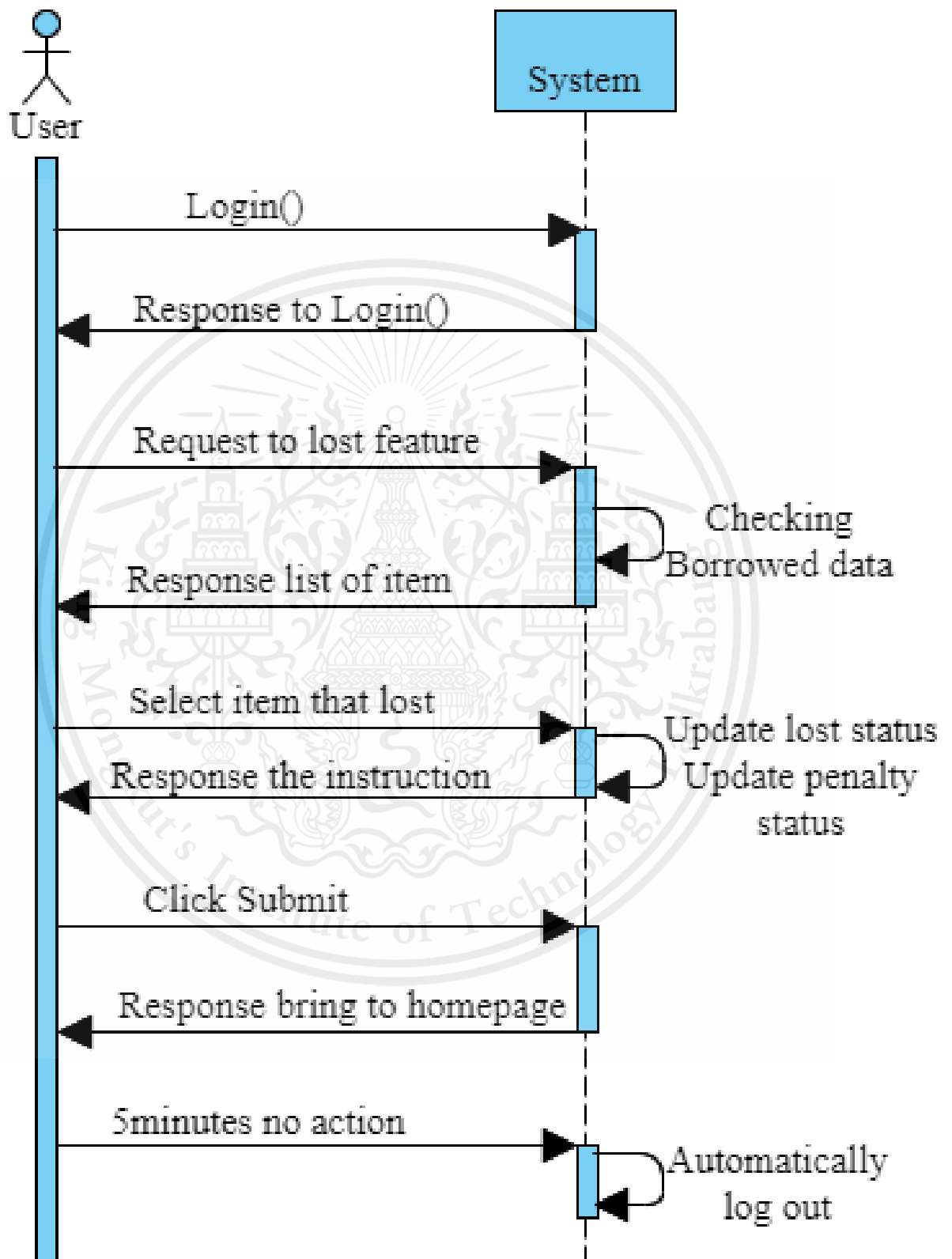

Figure 3.24 Diagram for user's lost feature

This material is reserved for educational use only, not allowed for commercial use.

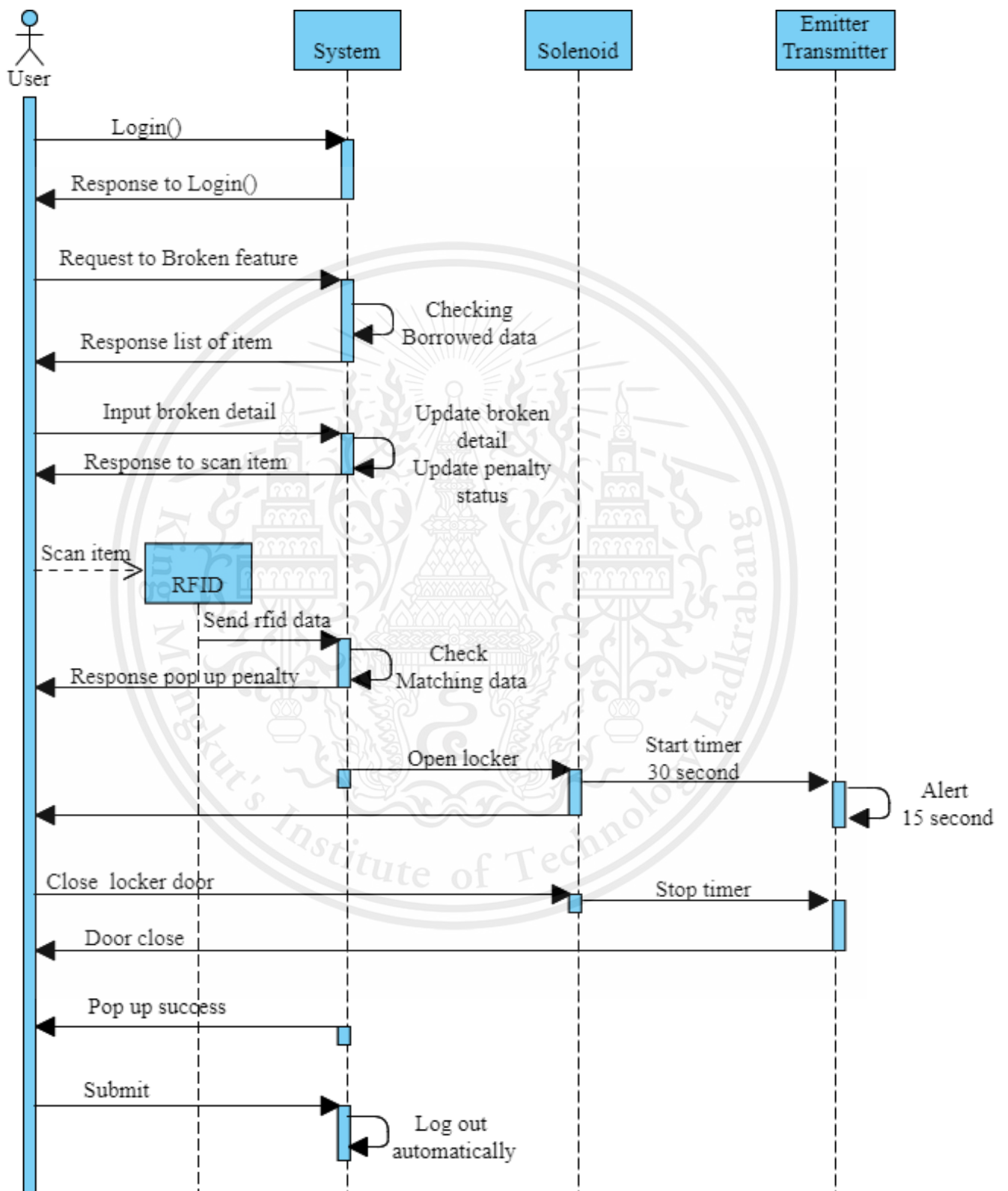

Figure 3.25 Diagram for user's broken feature

This material is reserved for educational use only, not allowed for commercial use.

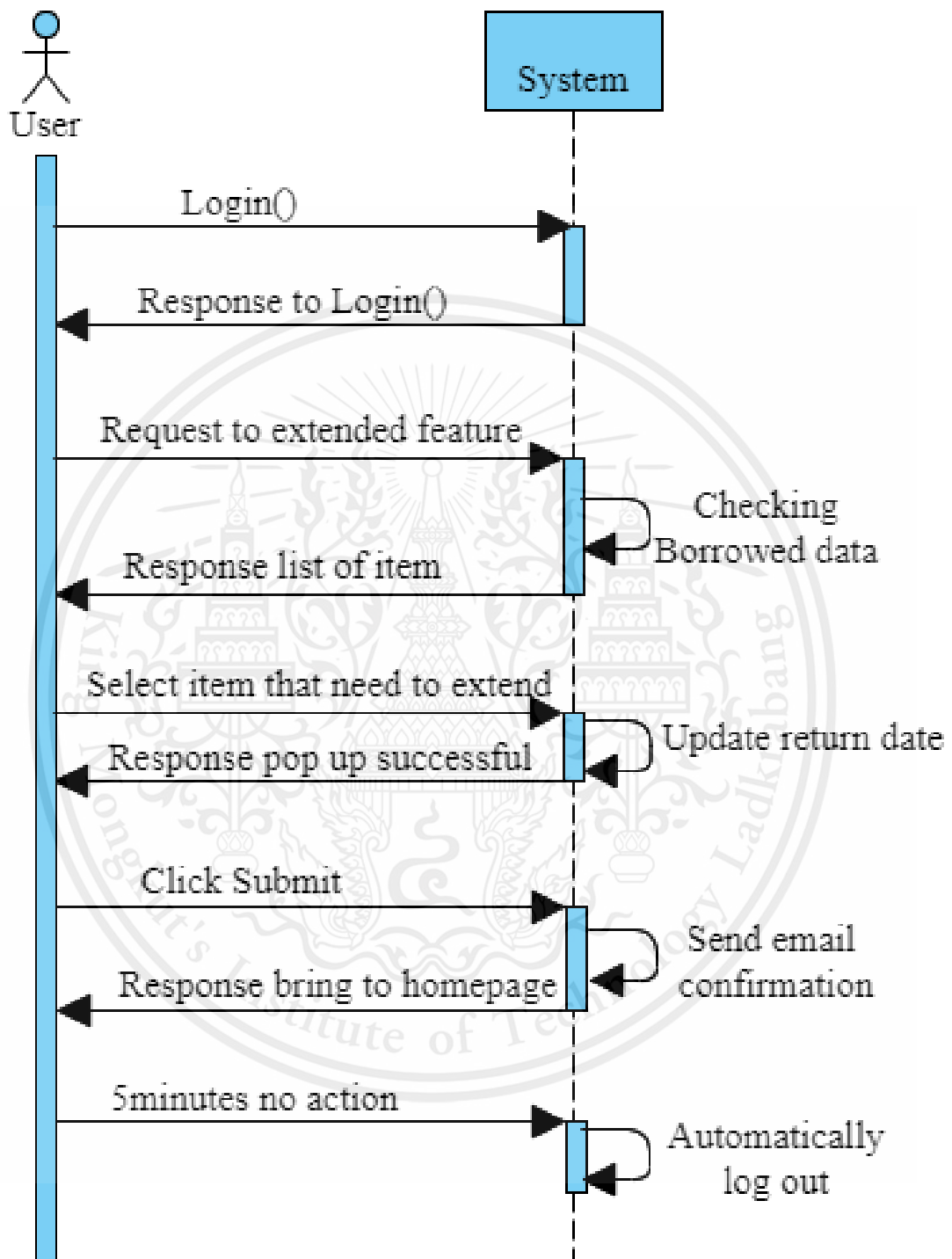

Figure 3.26 Diagram for user's extend feature

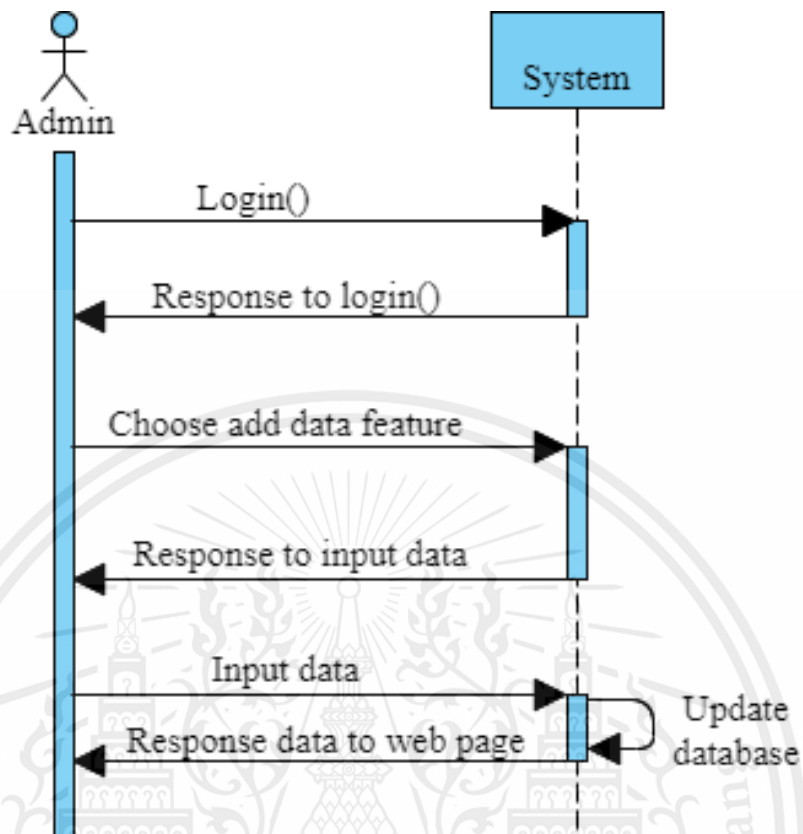

Figure 3.27 Diagram for admin's add data feature

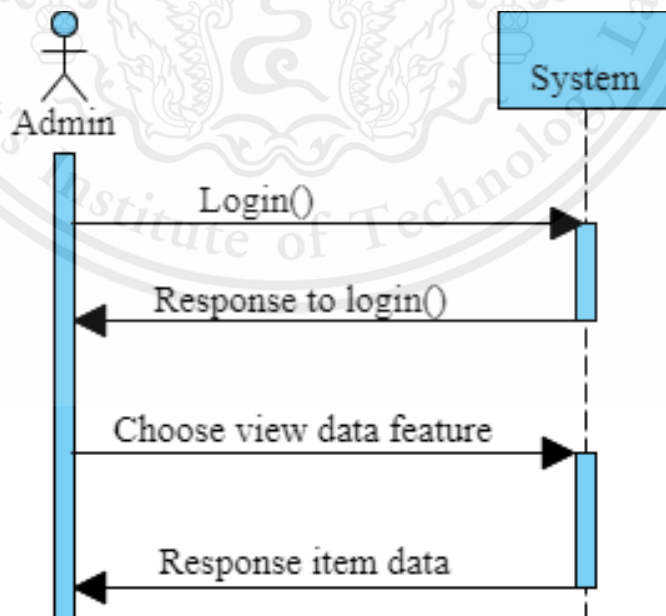

Figure 3.28 Diagram for admin's view data feature

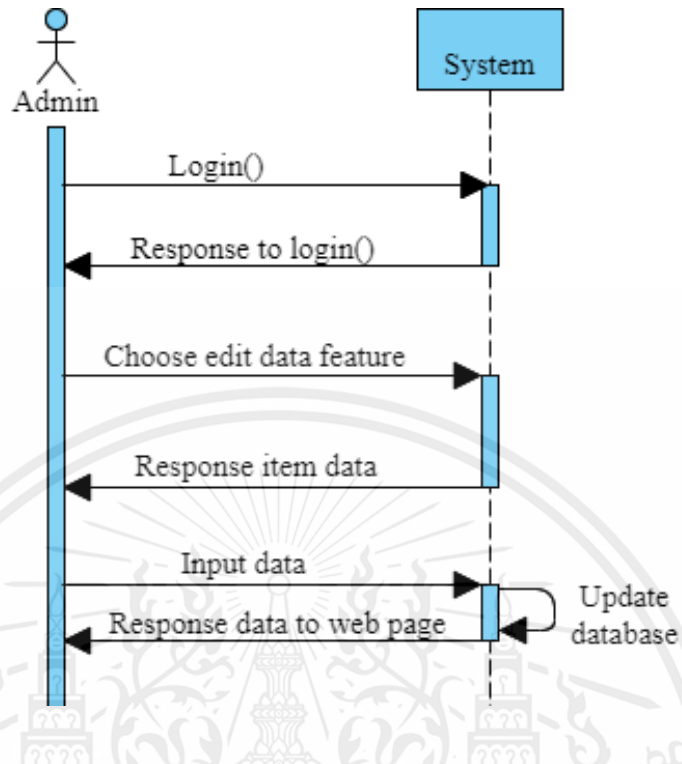

Figure 3.29 Diagram for admin's edit data feature

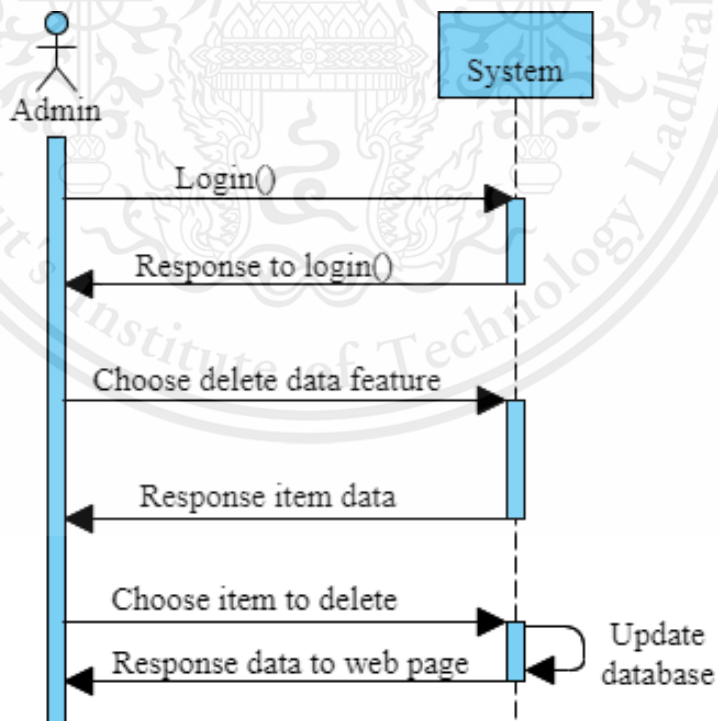

Figure 3.30 Diagram for admin's delete data feature

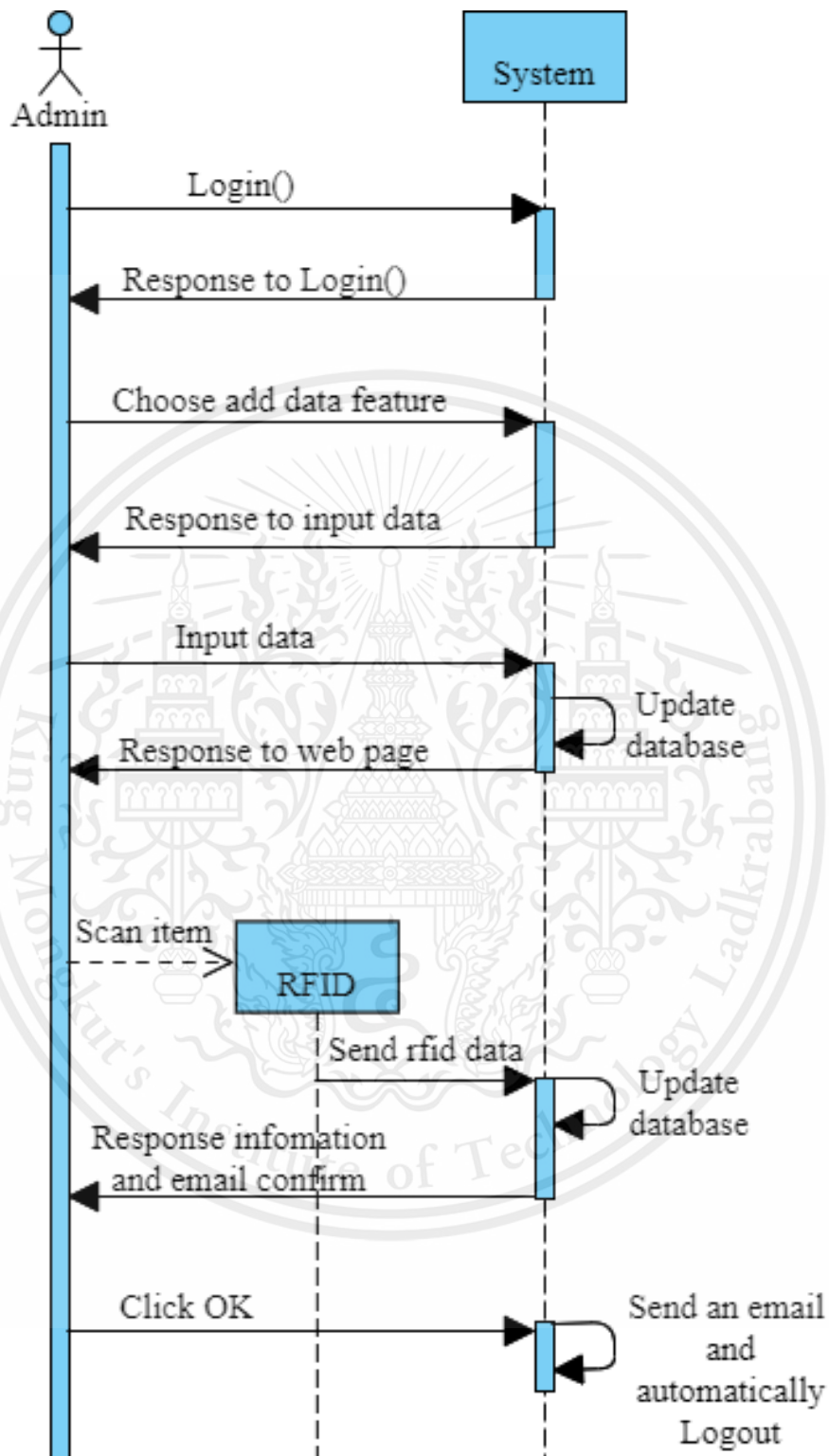

Figure 3.31 Diagram of admin's add item feature

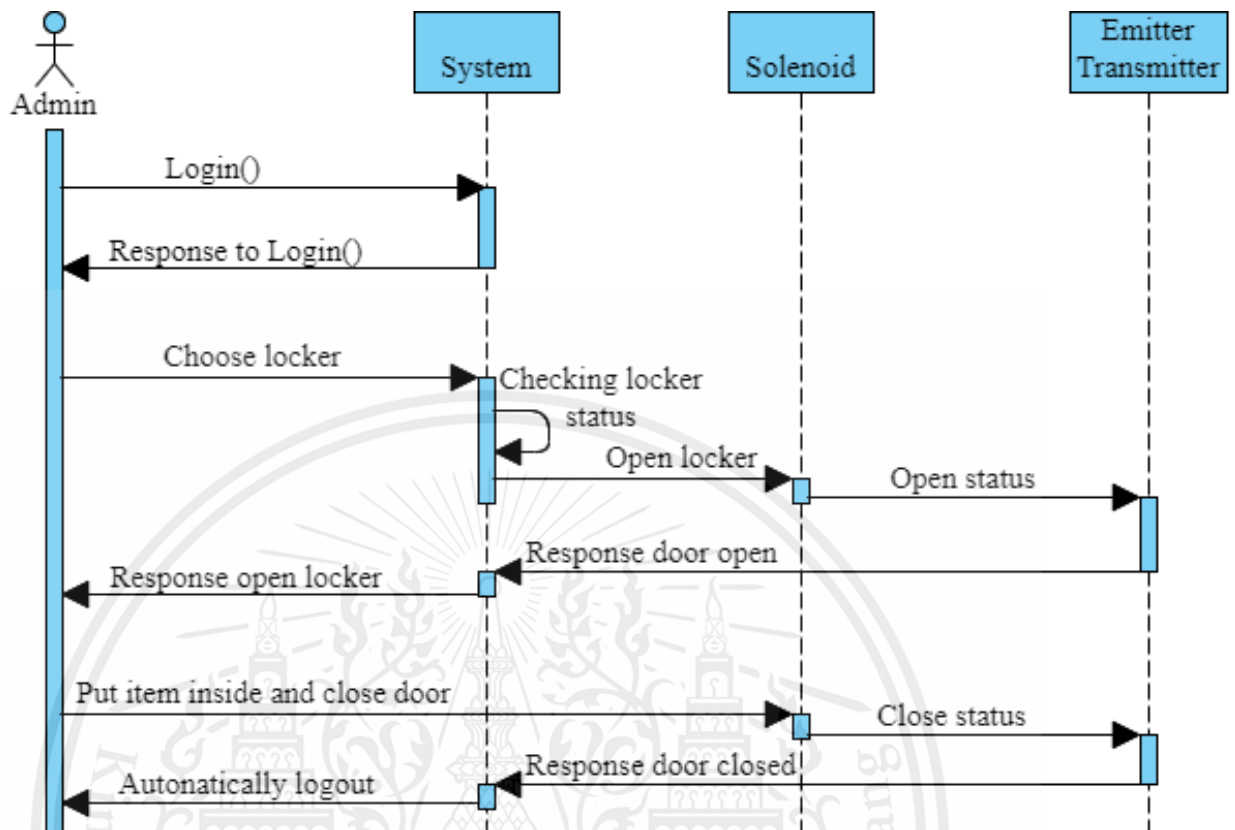

Figure 3.32 Diagram for admin's control locker feature

3.4 Database

The database of this project consists of ER diagram and database table. The ER diagram has the picture of ER diagram along with the explanation of the diagram. The database table describes each table with the description and the attributes that are used in this system.

3.4.1 ER diagram

The ER Diagram is a model used to explain the structure of a database. Explaining the structure and relationship of data consists of entities, attributes, and relationships. Entities in the system are materials or items that we are interested in, attributes are characteristics of the materials, while relationships refer to the relationships between the entities.

The first ER diagram of CIEON Inventory Management System has many tables. Consequently, the database should be redesigned to make it more efficient and the result of being redesigned is displayed in figure 3.33. This ER diagram contains 7 tables: user table, activity table, reserve table, category table, item detail table, locker table, and forget password token table. The relationship between each table is one to many.

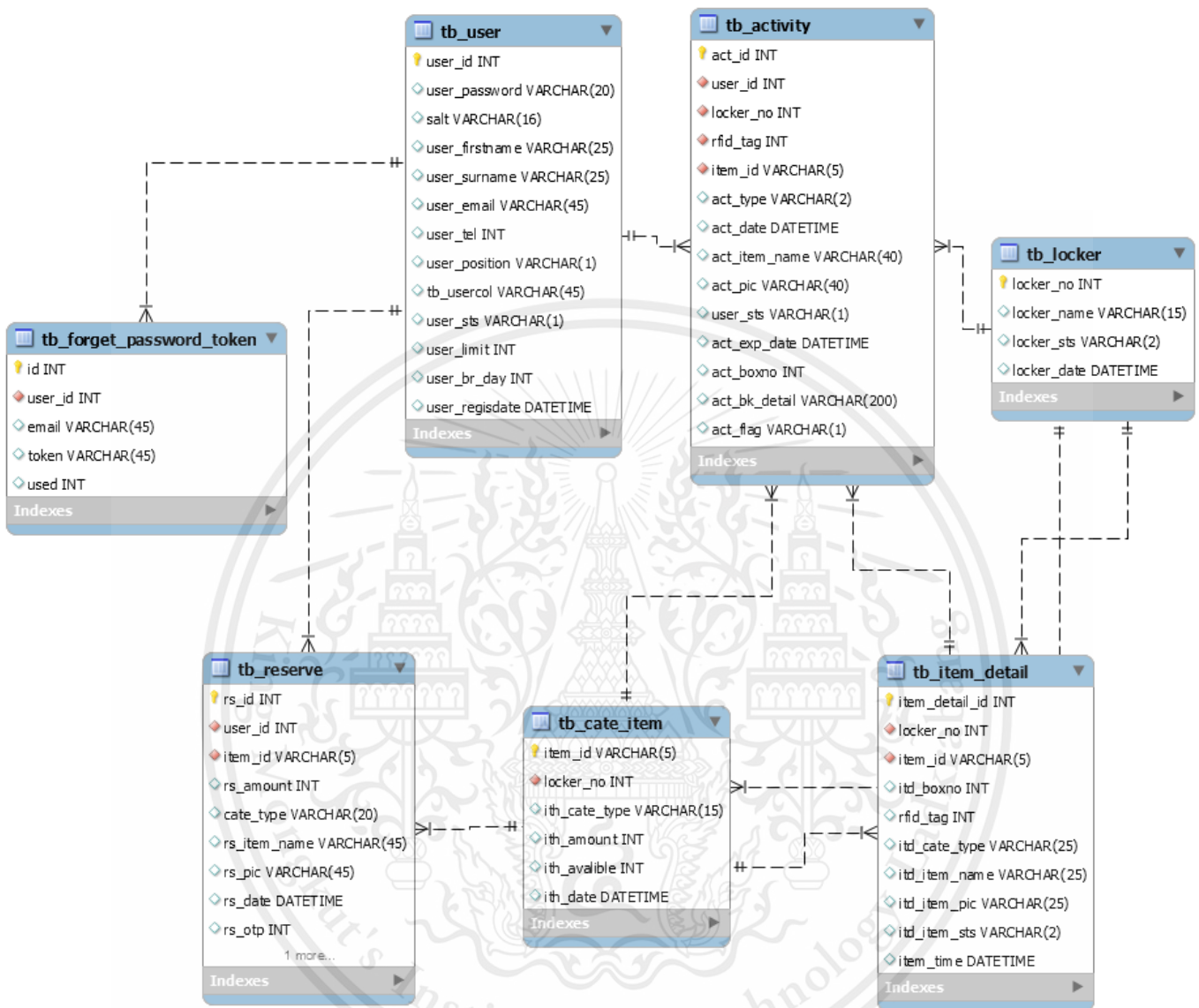

Figure 3.33 ER diagram of CIEON Inventory Management System

3.4.2 Database table

The database table of CIEON Inventory Management System contains 7 tables. Each table consists of attributes and data type with the description and each table has one primary key.

According to table 3.1, table user is used to contain all of the user information such as first name, surname, email, and password. Furthermore, it contains information that is used by the system, such as position, register date, status, and user borrow date.

Table 3.1: Database user

Attribute	Data type	Description	
user_id	Integer	Id generates for primary key	Primary key
user_tel	Varchar	User telephone number	
user_password	Varchar	Password of each user	
salted	Varchar	Random value use to make password more secure	
user_firstname	Varchar	User first name	
user_surname	Varchar	User surname	
user_email	Varchar	User email	
user_position	Varchar	User position: Teacher, Student, Admin	
user_limit	Integer	Number of item that each user can borrow	
user_regisdate	Integer	Register date of user	
user_sts	Integer	Status that user receive penalty or not	
user_br_day	Integer	Amount of date that user can borrowed	

According to table 3.2, table locker is used to contain all the information about the locker such as locker number, locker name, locker status, and locker register date which will be used when managing data and opening lockers.

Table 3.2: Database locker

	Data type	Description	
locker_no	Integer	Locker number	Primary key
locker_name	Integer	Locker name	
locker_sts	Integer	Status of locker that it open or not	
locker_date	Datetime	Date and Time when locker is adding	

According to table 3.3, table forget password token is used for stall token, and emails when the user uses the forget password features.

Table 3.3: Database forget password token

Attribute	Data type	Description	
id	Integer	Id generates for primary key	Primary key
email	Varchar	User email	
token	Varchar	Collect hash when do forget password process	
used	Integer	Status for system to see if this record is already use or not	

According to table 3.4, the table item detail is used for stall item information in almost all features. It contains RFID tags, locker number, item box number, item type, item name, item picture, and item status.

Table 3.4: Database item detail

Attribute	Data type	Description	
item_detail_id	Integer	Id generates for primary key	Primary key
rfid_tag	Varchar	RFID tag	
locker_no	Varchar	Locker number	
item_id	Varchar	Id of table cate_item	
itd_box_no	Varchar	Box number	
itd_cate_type	Integer	Category type	
itd_item_name	Integer	Item name	
itd_item_pic	Integer	Item picture	
itd_item_sts	Integer	Item status	
item_time	Datetime	Time stamp when add item	

According to table 3.5, table category is used for stall information about the type of items such as category type, item amount, and item available amount. This table is used for declaring the type of each item.

Table 3.5: Database category

Attribute	Data type	Description	
item_id	Integer	Id generates for primary key	Primary key
locker_no	Integer	The locker number	
ith_cate_type	Varchar	Date and time show when the user using our system	
ith_amount	Integer	Amount of all item in each category	
ith_avalible	Integer	Amount of item that available in the system	
ith_date	Integer	Date and time show when the user using our system	

According to table 3.6, the table reserve is used for reserve feature only. It contains all the reserved information that is created by the users in the reserve process such as reserve amount, item id, reserve date, item name, and OTP number which are used in further features.

Table 3.6: Database reserve

Attribute	Data type	Description	
rs_id	Integer	Id generates for primary key	Primary key
item_id	Varchar	Id of table cate_item	
rs_amount	Integer	Amount of item that user reserve	
rs_date	Datetime	Date and time that user reserve item	
cate_type	Varchar	Category type	
user_id	Integer	Id of table user	
rs_item_name	Varchar	Item name	
rs_pic	Varchar	Item picture	
rs_otp	Integer	OTP number	
rs_flag	Varchar	Status for system to see if this record is already use or not	

According to table 3.7, the table activity is used for record activity for each user and it collects all the information about the system such as RFID tag, activity type, item name, item box number, and activity date.

Table 3.7: Database activity

Attribute	Data type	Description	
act_id	Integer	Id generates for primary key	Primary key
user_id	Integer	User id	
locker_no	Integer	Locker number	
rfid_tag	Integer	RFID tag number	
item_id	Varchar	Id from category table	
act_type	Varchar	The type of activity	
act_boxno	Integer	Item box number	
act_item_name	Varchar	Item name	
act_pic	Varchar	Item picture	
act_date	Datetime	The date of activity	
act_exp_date	Datetime	The return date	
user_sts	Varchar	User status	
act_bk_detail	Varchar	Broken detail	
act_flag	Varchar	Status for system to see if this record is already use or not	

3.5 Design business model

This method clarifies the encounter issues that should be solved in the stock management system. Problem identification with customer insight is a critical point to emerge the objective and ideation of innovation, which is created to solve the issues. Moreover, it includes the business canvas model to analyze how this project gains profit and when the investor will be paid back.

3.5.1 Define pain points and customer insight

Many organizations encounter the lost item problem often, which increases the organizations' expenses. The result of issues being raised from poor inventory management is the owner did not recognize the exact amount of the current available item and did not realize which items is broken and lost. Moreover, the organization cannot know who took the item and who broke the items. Finally, the organization has to accept the expense of that lost item. Even though the lost item is not stolen but during the time it is needed, a good solution is to order a new one to replace the lost one because the items cannot be tracked.

3.5.2 Ideation and objective

The inventory management system becomes a good solution to track the item and reduce the lost items problem especially when the report and history of user activity is an important key to check and track the latest items in stock. In addition, self-borrowing and self-returning can reduce inventory staff and safe cost from hiring many staff who operate with the inventory system. Consequently, CIEON Inventory Management System aims to solve issues by checking equipment in the inventory to organize equipment to reduce the disrupted equipment and lost items by tracking the borrowers and items' process or status through the user's activity record on the system.

3.5.3 Business model canvas

The business model canvas is a business tool for simulating all parts of starting a business-like client, course to advertise, incentive, and money. CIEON Inventory Management System is an innovation that is helpful in the warehouse system. Therefore, the business model canvas is a necessary tool to extend this system and how this system is beneficial and is worth investing with. CIEON Inventory Management System business model canvas is shown in figure 3.34.

The business model canvas of this project describes the target customer, the value of this system, and how this system is used to gain revenue. Firstly, the customer segment is CIE laboratory, which will use a user manual as the training section and the document as a customer relationship. Web application and social media becomes a channel to reach the target customer. Value Propositions of this system are helping the inventory management, tracking users and items with the security to prevent lost items along with the scalable system. It is suitable for various customers with the customize size and equipment to support customer desire. Key partners are divided into two groups: admin and customers who are teachers and students. The key activity of this system and the aim of this project is tracking users and items. Once the inventory

management lets the admin know the current items are in stock, the online and offline website can allow users access to the system. Alerts help admins realize when they have to manage the inventory, and alarms inform the admins to secure the inventory. Key resources required in this system are hardware, software, and employees who will be the operator. In addition, this system cost structure needs hardware manufacturer. No revenue stream is in this project but the system can reduce the expense of buying new equipment to replace lost equipment. This system can prevent lost costs.

3.5.4 Business cost analysis

Based on figure 3.35, it shows the cost of investment CIEON Inventory Management System in 6 rooms locker. The overall cost includes all hardware equipment and installation.

The investment cost data shown in figure 3.36 illustrates the list and cost of goods or services. According to figure 3.37, it presents the variable cost of each hardware so the customer can customize the amount of equipment. This project is a scalable system. For example, if the customer does not require a board, the cost of board will be cut. In figure 3.38, it presents the sample calculation of the cost with amounts of 6 rooms locker requirements hardware. In addition, a large-scale sample 24 room locker cost can be discounted since it is ordering equipment on a large scale.

According to figure 3.39, the CIE inventory expense in 7 months is the real data. Calculating the forecasting average data in one month by dividing the original amount with the amount of month which is seven months. Lastly, multiply one-month average forecasting amount by 12 to get the result amount of one year forecasting average price. The method to calculate the return of investment and payback is shown as follows:

- Return of investment = $\frac{(\text{Benefits or one year forecasting average price}) - (\text{Cost of investment in system})}{(\text{Cost of investment in system})}$
- Payback = $\frac{(\text{Benefits or one year forecasting average price})}{(\text{Cost of investment in system})}$

Finally, the result of return of investment and payback are presented in figure 3.40. The investor will gain the payback in 1.36 month. Figure 3.41 shows selling outsider cost. It will charge a software solution fee of 180,000 Baht as a part of investment cost because the system has to be customized based on the customer.

3.6 Summary

This chapter described about the overall design and overall structure of CIEON Inventory Management System. It also describes architecture, sequence diagram, and uses case diagram of each feature. Furthermore, it provides information about ER diagram and database use for the system. All methodology is used in further design and implementation. Moreover, the result in chapter 4 uses all of the methodology mentioned above.

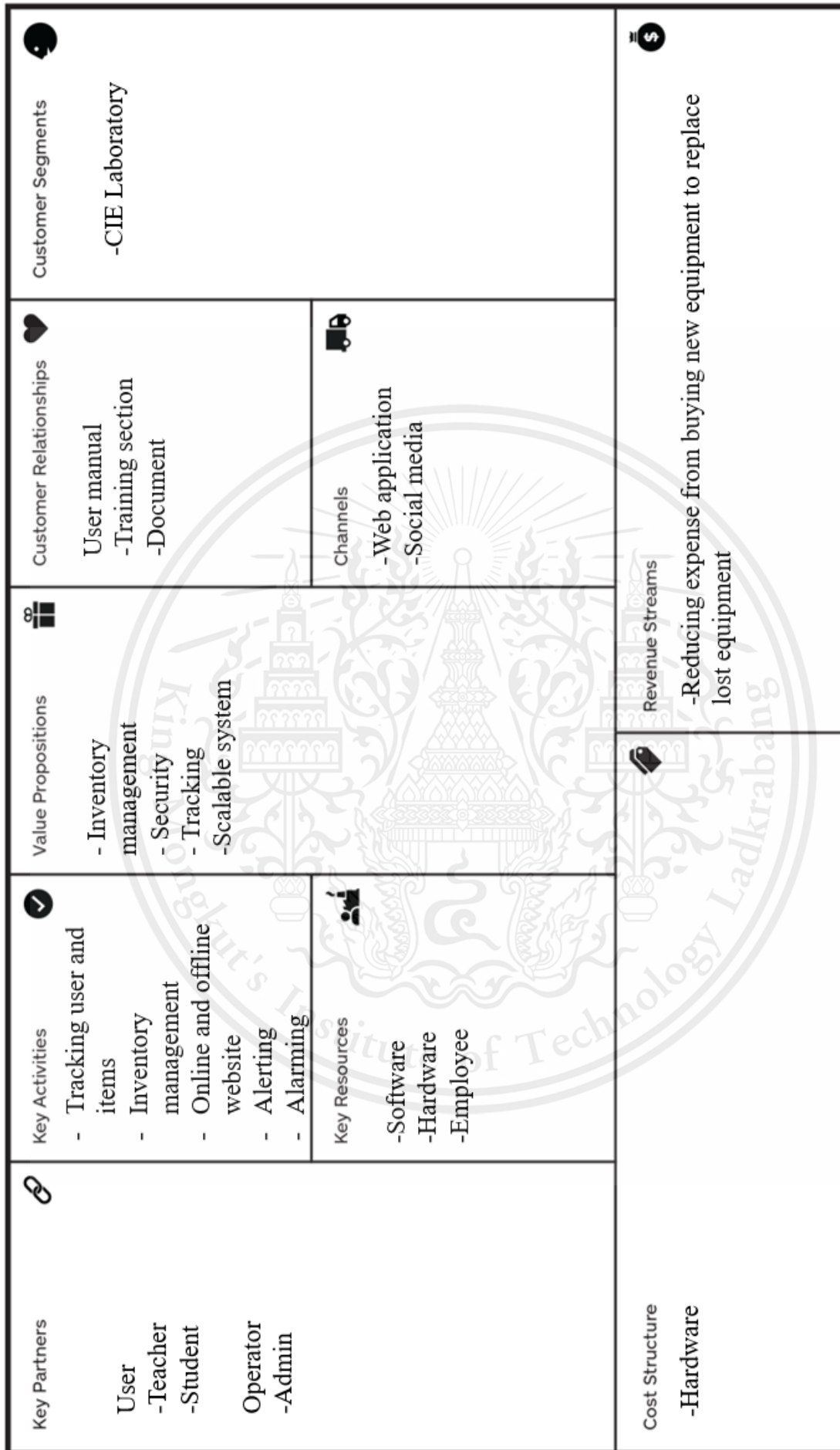

Figure 3.34 Business model canvas

CIEON Inventory Management System 1 locker 6 rooms				
Number	Lists	Normal price(Baht)	Amount	Overall Cost
1	Magnetic Lock	320	6	1920
2	RFID reader	12840	2	25680
3	RFID Tags from China (\$ 0.14 per unit)	4	170	680
4	Locker	3890	1	3890
5	Small boxes R450 to keep item (50 pieces)	3.4	105	357
6	Large boxes 1000/o (25 pieces)	6.5	72	468
7	Small baskets	23	1	23
8	Large baskets	47	1	47
9	LCD Screen panel(Samsung tab A)	4900	1	4900
10	Board			
	Raspberry Pi (Thaieasyelect.com)	1980	2	3960
	Arduino Uno (Thaieasyelect.com)	910	2	1820
11	Sensors			
	Emitter and transmitter	25	6	150
	Siren(Alarm) at the door	90	1	90
	Siren(Alarm) at the locker	90	1	90
	Relay 5 V 4 Channel	175	3	525
12	Jumper wires(40 wires per pack)	60	10	600
13	Podium	1500	1	1500
14	Box to keep hardware behind locker	249	1	249
15	Hardware Installation	5000	1	5000
			Final Cost	51949

Figure 3.35 CIEON Inventory Management System cost

Item Fixed						
Number	List		Price	Amount	Overall cost	
1	RFID reader		12840	2	25680	
2	Locker					
3	LCD Screen panel(Samsung tab A)		4900	1	4900	
4	Sensors					
	Siren(alarm)		90	2	180	
	Emitter and transmitter		25	6	150	
	Relay 5 V 4 Channel		175	3	525	
	Magnetic lock		320	6	1920	
	Jumper wires(40 wires per pack)		60	10	600	
5	Podium		1500	1	1500	
6	Board					
	Raspberry Pi (Thaieasyelect.com)		1980	2	3960	
	Arduino Uno (Thaieasyelect.com)		910	2	1820	
Human resource						
Number	List		Price	Amount	Overall cost	
1	Hardware Installation		5000	1	5000	
					Overall cost	46235

Figure 3.36 Investment cost

Item variable						
Number	List	Rate dollar to be Baht	Price in dollar	Price in Baht	Amount	Overall cost
1	RFID Tags					
	RFID Tags from China (\$ 0.06 per unit) at leasr 100 units	32	0.06	1.92	100	192
	RFID Tags from China (\$ 0.14 per unit) at least 1 unit	32	0.14	4.48	1	4.48
2	Small boxes					
	Small boxes R450 to keep item (50 pieces)			3.4	1	3.4
	Small boxes R450 to keep item (450 pieces)			3	1	3
	Small boxes R450 to keep item (1350 pieces)			2.6	1	2.6
	Small boxes R450 to keep item (3150 pieces)			2.4	1	2.4
3	Large boxes					
	Large boxes 1000/o (25 pieces)			6.5	1	6.5
	Large boxes 1000/o (250 pieces)			5	1	5
4	Small baskets			23	1	23
5	Large baskets			47	1	47
6	Box to keep hardware behind locker			249	1	249

Figure 3.37 Variable cost

6 rooms locker (170 items)		24 rooms locker (680 items)	
Amount	Overall cost	Amount	Overall cost
		680	1305.6
170	761.6		
105	357	420	1260
72	468	288	1440
1	23	4	92
1	47	4	188
1	249	4	996
Overall Cost	1905.6	Overall Cost	3976
		Original price	7622.4
		Discount	3646.4
		Discount percent	47.84%

Figure 3.38 Sample variable cost

CIE Inventory Expense	
7 months (Real data)	266620
1 month (Forecasting average)	38088.57
1 year (Forecasting average)	457062.86

Figure 3.39 CIE inventory expense in items

CIEON Inventory Management System	Cost 1 year (Baht)		ROI	779.83%
Costs of investment in system	51949		Payback (Month)	1.36
Benefit(reduce cost, cost only expent)	457,062.86			
Payback(period per year)	0.113658327			
Payback(month)	1.363899924			
CIEON Inventory system cost	51949			
CIE Inventory Cost				
7 months (Real data)	266,620			
1 month (Forecasting average)	38,088.57			
1 year (Forecasting average)	457,062.86			

Figure 3.40 Return of investment and payback in CIE

Item Fixed					
Number	List	Price	Amount	Overall cost	
1	RFID reader	12840	2	25680	
2	Locker				
3	LCD Screen panel(Samsung tab A)	4900	1	4900	
4	Sensors				
	Siren(alarm)	90	2	180	
	Emitter and transmitter	25	6	150	
	Relay 5 V 4 Channel	175	3	525	
	Magentic lock	320	6	1920	
	Jumper wires(40 wires per pack)	60	10	600	
5	Podium	1500	1	1500	
6	Board				
	Raspberry Pi (Thaieasyelect.com)	1980	2	3960	
	Arduino Uno (Thaieasyelect.com)	910	2	1820	
Human resource					
Number	List	Price	Amount	Overall cost	
1	Hardware Installation	5000	1	5000	
CIEON Inventory Management System Platform					
Number	List	Price	Amount	Overall cost	
1	Software solution	180000	1	180000	
				Overall cost	226235

Figure 3.41 Selling outsider cost

CHAPTER 4: EXPERIMENTAL RESULT

4.1 Introduction

Developers will refer to each cycle that arises as a result of the site's development by dividing it into 23 major components in this section. The 23 fundamental parts are authentication, registration, edit profile, forget password, homepage (user and admin), borrow, return, reserve, broken, lost, enter OTP, extend date/time, add data, view data, edit data, delete data, borrow report, return report, extend report, penalty report, broken report, lost report, and controlling locker. It also provides examples of webpage and hardware design and shows the sequence of each feature.

4.2 Testing summary

CIEON Inventory Management System testing separates the overall system into the software system and hardware system. This section will be describing the full sequence of the system in detail and providing example pictures of software and hardware process.

4.2.1 Overall system

According to figure 4.1, it presents the result of CIEON Inventory Management System in both the hardware part which consists of sensor, locker, wire and the software part which is web application.



Figure 4.1 The CIEON Inventory Management System

This material is reserved for educational use only, not allowed for commercial use.

4.2.2 Software system

The software system describes the process step by step on the online and offline website of users with the images support to make the explanation clear.

4.2.2.1 Authentication

The website's initial page is a login page. Before pressing the login button, the user must fill in the username and password. However, if the user does not fill out either, the website will notify them that they must fill out the required information. If the wrong username or password is entered, the website will display an announcement with the message “Username or password is incorrect. If you forgot your password, please use the ‘forget password’ button.” as seen in figure 4.3. Nonetheless, if the user enters the correct username and password, he or she will be able to access the website. Furthermore, a user who does not type @ in the email box, the system will alert the user to type @ in the email box. Apart from typing data, the top of the page also locates the back button. If the user selects it, then the system will direct the user back to the homepage for the users who are still not logged in.

4.2.2.2 Registration

The method of registration starts by choosing the register button on the dropdown of homepage. The system will let the users choose between teacher and student. If a user chooses student, the system will display the registration form as shown in figure 4.4. Users have to fill in all the required data incasements. After the user fills in their student number, the system will automatically generate the email using that student number. On the other hand, the teacher registration will be displayed as shown in figure 4.5. The user has to fill in all the required data incasements. After the user fills in their full name and surname, the system will automatically generate the email using their ‘full name’ followed by a full stop and the first 2 letters of their surname.’ In addition, users who type a password below six characters will be alerted by the system to type a password over or equal to six characters. Similarly, the system also will not allow a user to type a password that has more than twenty characters. The password box has the eye icon that can hide and show the password upon clicking it. Lastly, the back button on the top of the page will direct the user back to the homepage for the users who are still not logged in.

4.2.2.3 Edit profile

The edit profile step starts with the user clicking the profile button on the dropdown from the website header. Then the system will take the user to the profile page as shown in figure 4.6, where the user can edit their data. The first name and surname length cannot be zero or over twenty characters. If a user does not type anything in the first name or surname box, the system will require the user to fill out the data. After the users finished filling in their data, click the save button and the information will automatically be saved. However, the user email and the amount of items that user can reserve and borrow cannot be edited.

4.2.2.4 Forget password

The forget password feature starts by the user filling in their email and clicking the forget password button in the forget password page displayed in figure 4.7. The system will send a link to their email as displayed in figure 4.8. The email will contain a link for users to change their password. After the user clicks the link from their email, it will take the user to the change password page displayed in figure 4.9. Users can change their password and it will automatically update to the database after submitting. In addition, once the user clicks the back button on the top of the page, the system will take the user back to the homepage for the users who are still not logged in.

4.2.2.5 Homepage

After a successful login, each user will be divided into groups to access different pages based on their database position. Whether you are a student or a teacher, you will be directed to the same homepage. There are two homepages on the offline and online websites: student and teacher. Each homepage has the logout button on the top right of the website that will allow users to logout from the website.

Figure 4.10 shows the offline homepage website has 4 features that can be chosen by the dropdown: borrow, broken, enter OTP, and return. On the other hand, the online websites have 3 features that can be chosen by the dropdown: reservation, lost, and extend as shown in figure 4.11. The user who has the position of admin will access the admin homepage that only admins can access. The admin homepage has alerts to let admins realize the items that are running low on stock as displayed in figure 4.12. Nevertheless, the admin page has a menu bar on the left which contains home, description, admin feature, teacher feature, student feature, item feature, category feature, locker feature, history, borrow report, return report, extend report, penalty report, broken report, and lost report.

4.2.2.6 Borrow

When the user chooses the borrow feature button, the website will take the user to the borrow page as shown in figure 4.13. On the borrow page, there is a menu bar on the top of the page which allows the user to change the feature easily. In this feature, the users can borrow items that they want by searching the selected items through the search bar shown in in figure 4.14 or by clicking category to search items in that category. After that, the user can select an item by pressing the item picture. The menu bar also has a log out button.

Figure 4.15 shows the item name, available amount, and locker number with the related items. The user can choose the amount by clicking dropdown and select the amount before clicking borrow. In the case user choose the items exceeding the amount of reservation and borrowing click, the system will pop up a message “Borrow over limit” as displayed in figure 4.16. Nevertheless, the system will show the message “Success” as shown in figure 4.17 when the user borrows the item equal or less than the available amount. Once the user adds borrow item, it will show the current borrow item amount on the cart icon in the red circle with the amount of the current item inside the cart as shown in figure 4.15.

On the top left of the website page, there is the CIEON Inventory Management System logo which is used to return to the homepage. Furthermore, the top of the page also has a cart icon for users to see all the items they selected and the date for returning the items. After pressing the cart icon, it will show a borrow list as shown in Figure 4.18. The summarized page has the borrow list, return date, return date description, plus and minus button to adjust the item amount in the list with the bin icon to delete the item including the delete all button, and the borrow button as shown in figure 4.19. If the user clicks the bin icon of delete items in front of the item, the system will show the message, “Do you want to delete the item?” as shown in figure 4.20. If user clicks the ok button, the system will delete that item out of the list but if the user selects the cancel button, then the system will cancel the delete feature and go back to the list. Including in case the user clicks the bin icon of delete all, the system will show the message, “Do you want to delete all items?” as shown in figure 4.21. If clicking ok button, the system will delete all the items in the list but if the user selects the cancel button, then the system will cancel the delete feature and go back to the list. Next, the user clicks the borrow button and the information will be sent to the user’s email. The email sent contains the details of items that are borrowed and the return date of the items. Furthermore, if the user chooses to borrow the out of stock item then the system will show the message “Unfortunately, the following item that you reserve are now out-of-stock.”.

4.2.2.7 Return

When the user chooses the return feature button, the website will take the user to the return page that has the menu bar on the top of the page for the user to change the feature easily. It has the CIEON Inventory Management System logo which can be used for returning to the homepage and there is a logout button in the dropdown.

The return page has the borrowed item, which consists of item name, the amount, the return date, box number, RFID tag number, and the return button as shown in figure 4.22. The user can choose the return item by pressing the return button of that item, then the locker door of the return locker will automatically open. When the locker door is opened, the timer will start. If the locker door opens for more than 30 seconds, the alarm will alert the user to close the door to stop the alarm. The system will pop up a message, “Do you want to proceed?” as shown in figure 4.23. If yes, the user can continue to return the item but if no, the system will automatically logout. Additionally, users who return items late will receive the penalty that makes the user unable to use the borrow, reserve, and extend feature.

4.2.2.8 Reserve

Once the user’s authentication on the online website is completed, the user can choose the reservation feature button on the menu bar on the top of the homepage and the website will take the user to the reservation page. CIEON Inventory Management System logo is used in order to return to the homepage and there is a logout button in the dropdown. The menu bar on top of the page will be helpful to allow users to change the feature easily.

In this feature, users can reserve items by selecting the items. Figure 4.24 shows the system contains capable features such as a search box or category menu bar to avoid wasting time from finding items. Once users select an item, the system will move the user to the selected item page to see the number of that item in stock. It also allows the user to choose the amount of reservation by using the drop down to choose the amount then clicking the reserve button shown in figure 4.25 to update the data in the user's cart. Although user choose the items exceeding the amount of reservation and borrowing click, the system will pop up a message "Reserve over limit".

A user's cart is located on the menu bar on the top of the page as a cart icon. Click the cart icon to see the reserve order summary pops up as shown in figure 4.26. This pop up will show the reserved items name and amount. At the bottom of the pop up, there is a reserve button for users to see all the items they selected and the date for returning the items. In the case that the user wants to cancel, it will return to the reserve page. On the other hand, upon selecting reserve, the system will move to the reserve summarized page to repeat all reserve list as shown in figure 4.27. The reserve summarized page presents the reserve item's name, amount, pick up date, pick up date description, plus and minus button to adjust the item amount in the list. It also includes the bin icon to delete the item and the delete all button to delete all items in the reserve list, and the reserve button. If the user clicks the bin icon of delete items in front of the item, the system will show the message, "Do you want to delete the item?" as shown in figure 4.28. If user clicks the ok button, the system will delete that item out of the list but if the user selects the cancel button, then the system will cancel the delete feature and go back to the list. Including in case the user clicks the bin icon of delete all, the system will show the message, "Do you want to delete all items?" as shown in figure 4.29. If clicking ok button, the system will delete all the items in the list but if the user selects the cancel button, then the system will cancel the delete feature and go back to the list.

After the user clicks the reserve button, the OTP will be sent to the user's email. The email sent contains the OTP number which will be used in the enter OTP feature. By the same way, when the user clicks the reserve button, the system will pop up the message "Do you want to proceed?". The system will automatically logout if the user chooses no. However, if the user chooses yes, the system will go back to the homepage. In addition, if the user clicks to reserve the out of stock item then the system will show the message "Unfortunately, the following item that you reserve are now out-of-stock."

4.2.2.9 Broken

After the users complete the authentication process on the offline website, the website will redirect them to the homepage, which has a menu bar at the top that allows them to easily change features. The website will redirect the visitor to the broken page, as shown in figure 4.30 if the user selects the broken feature button. The description of the items that the user borrowed is displayed on the broken page, which contains the name of the item, the number of each item, the RFID tag number, and the broken button. When the user selects the broken button at the back of the item summary, the system will display a broken detail box in figure 4.31, allowing the user to leave

comments about the item's difficulties and prompting if the user wants to continue or logout. Either choice, the user would be able to place the broken object in the broken locker by opening the door. Once the locker door is opened, the timer will start. If the locker door opens for more than 30 seconds, the alarm will alert the user to close the door to stop the alarm. The system then will automatically logout. Lastly, the penalty alert will be shown on the user's homepage. After confirming the lost information, the penalty email will be sent to that user, as well as an announcement email to the admin. Once the users who got penalized login again to website, it will show the penalty status as shown in figure 4.32.

4.2.2.10 Lost

After logging into the system successfully, users can choose the feature on the menu bar on the top of the page. When the user chooses the lost feature button, the website will take the user to the lost page. According to figure 4.33, the lost page displays the borrowed item lists with item name, box number, RFID Tag number, return date, and the lost button. In this feature, the user has to select a lost item by clicking the lost button near that item. After clicking, the system will pop up the message, "Do you want to proceed?" as shown in figure 4.34. The system will automatically logout if the user chooses no. However, if the user chooses yes, the system will go back to the lost page. Lastly, the penalty alert will be shown on the user homepage. The penalty announcement will be alerted to the user as presented in figure 4.35.

4.2.2.11 Enter OTP

After authentication on the online website is successful, the homepage will be displayed. The user who receives the OTP from the reserve process will fill in the OTP number at the enter OTP feature. The user begins with choosing the enter OTP feature on the top menu bar, then the system will take the user to the enter OTP page. Figure 4.36 presents the enter OTP page, where the user can fill the OTP number and submit the data. In the case that the OTP is correct, the user will be able to see a reserved item list that includes a summary of the reservation item, item name, amount, pick-up date, and return date. After pressing the submit button, the user can take the selected item. The system will command that the door locker containing the desired item to open. Once the locker door is opened, the timer will start. If the locker door opens for more than 30 seconds, the alarm will alert the user to close the door to stop the alarm. Lastly, the system will automatically logout. Additionally, users have to take the borrowed item to scan the item tags with the RFID reader at the panel to update the RFID tag that is borrowed. On the other hand, if the filled in OTP number is incorrect over 3 times, the system will pop up a message, "Your OTP is not correct more than 3 times, and it will expire soon. Please use the borrow feature instead," as displayed in figure 4.37.

4.2.2.12 Extend date/time

When a user clicks the extend date/time button, the website will lead them to the extend date/time page, where they can extend the date and time of items they have borrowed. The extended page, as shown in figure 4.38, includes a list of objects that the users have already borrowed as well as the due date. Users can select all of the

items for which they would like to adjust the return date then click the extend button. After the user finishes the extend process, the system will display, “Do you want to continue?”. If the user chooses the ok button, then the system will bring the user to the homepage. However, if user presses cancel button, the system will automatically logout.

4.2.2.13 Add data

The admin begins with doing authentication on the online website. Once the admin enters the website, the admin must choose to add data feature, then the system will take the admin to add data page, which is displayed in figure 4.39. The admin must type all the required data and click the save button to insert the data. After that, the system will take the admin to view new data on the view page. However, if the admin chooses the cancel button, the system will take the admin to the view page.

4.2.2.14 View data

The admin begins with doing the authentication on the online website. Once the admin enters the website, the admin must choose to view data feature then the system will take the admin to the view data page. An example of view data is displayed in figure 4.40. Inside the view page, there are CSV, copy, and print data to help the admin gather the data and make a report. Clicking CSV to download data in that page in terms of excel. Clicking copy to copy all the data in the view page and clicking on print to print all the data in that page. Figure 4.41 shows the number of pages where the system has a lot of data. Every page in the admin page will have a logout button on the menu bar on the left of page to logout of the system.

4.2.2.15 Edit data

The admin begins with doing authentication on the online website. Once the admin enters the website, the admin must choose to view data feature then the system will take the admin to the view data page. Then choosing the edit icon button, the system will show the message, “Do you want to edit?” as displayed in figure 4.42. The admin selects the ok button, and the system will move the admin to edit the data page as shown in figure 4.43. The admin can edit the data and press the save button to update the data and go to view the data that is updated. Nevertheless, if the admin chooses the cancel button, the system will move the admin to view the current data.

4.2.2.16 Delete data

The admin does the authentication on the online website successfully. The admin enters the website and must choose the view data feature then the system will take the admin to view data page. Choose the bin icon button, and the system will show the message, “Do you want to delete?” as displayed in figure 4.44. The admin selects the ok button, and the system will delete the data on the same row by selecting the bin icon. Finally, the system will move the admin to view the most updated data excluding the deleted data. On the other hand, if the admin chooses the cancel button, the system will move the admin to view the current data.

4.2.2.17 Add item

When the admin logs in to the system using the authentication method, the system will display the admin page. Figure 4.45 displays the add item page, which the admin has to select the item function before choosing the add item feature to type the required item data and save the data. The system will insert the new data into the database and the system will move the admin to view the updated data. If the admin presses the cancel button, the system will take the admin to view the item that shows the current information. The RFID tag number in the database is zero as shown in figure 4.46. The admin needs to scan the RFID tag with the RFID reader to update the new RFID tag number in the database.

4.2.2.18 History

These features will only appear if the users are admins. When the admin chooses the history feature, the website will take the admin to the history page. According to figure 4.47, the history page contains all the information of the activity's user, and it also provides search engines to help the admin find data. All of the information is fetched from the database where it updates based on the usage of users in each feature. There is a delete icon, which is a delete button to erase each activity. If the admin presses the delete icon and presses the ok button on the pop up message, "Do you want to delete?" that row data will be deleted but if the admin decides to click cancel, the system will go back to the history page. Furthermore, a clear history button is used to delete the information by setting the first day and last day to delete data as shown in figure 4.48.

4.2.2.19 Reports

These features will only be allowed only for admins. There are 6 reports in this system, which are borrow report, return report, extend report, broken report, penalty report and lost report. Reports contain information's of users and item details that happen on each activity. For instance, penalty report has the user's name, RFID Tag and cause of penalty such as broken. The search engines are for admins. Users can be penalized for a variety of reasons, including losing items, destroying objects, and returning items late. Borrow, return, extend, broken, and lost report shows user's data with the RFID tag and date. Broken report have more data in the broken data section that is different to others' reports. Figure 4.49 shows an example of a borrow report.

4.2.2.20 Controlling locker

These features will only appear if the users are admins. The process starts with the admin logging in the system via the offline website. The system will show the control locker page as shown in figure 4.50. The admin can open any locker by pressing the open button to open the selected locker. Lastly, the admin can logout by pressing the logout button at the top of the website.

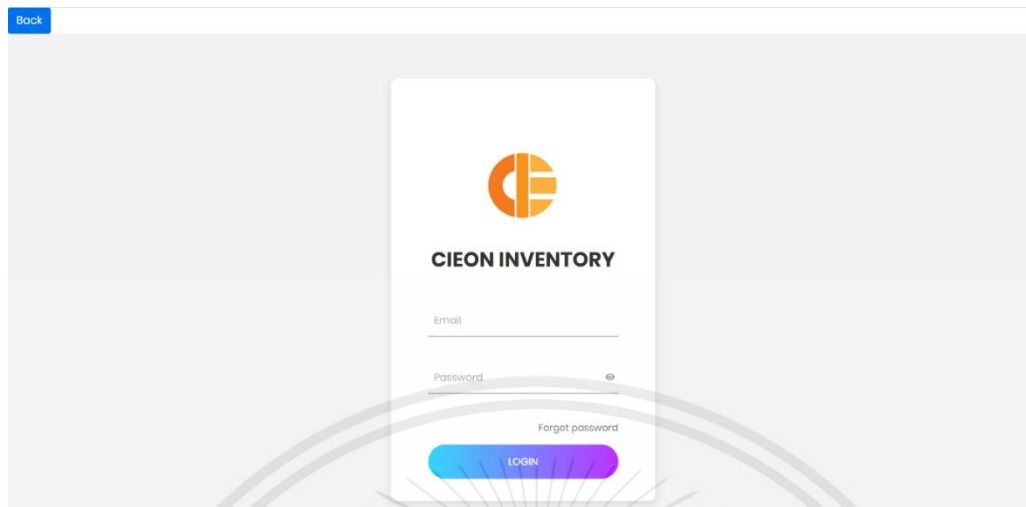

Figure 4.2 The login page

cieinventory.ga says
 Username or password is incorrect. If you forgot your password, please use the 'forgot password' button.

OK

Figure 4.3 The system announces message “Username or password is incorrect. If you forgot your password, please use the ‘forgot password’ button.”

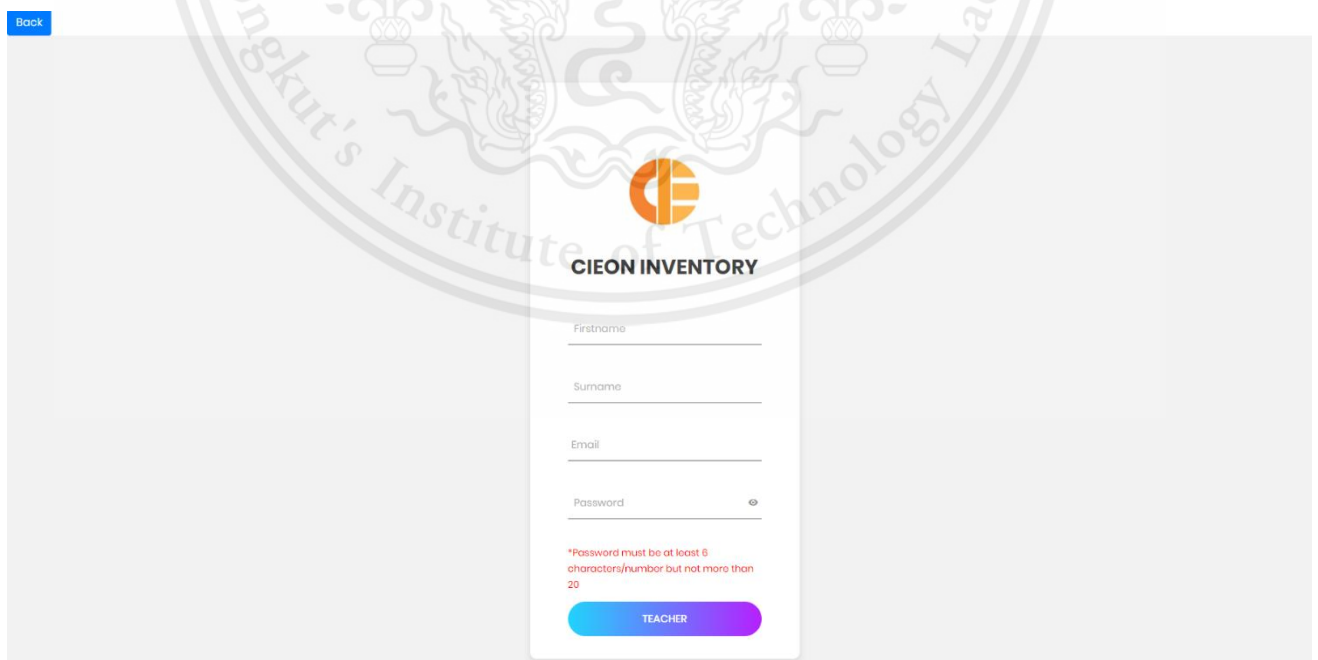

Figure 4.4 The registration form of student

Back

The screenshot shows a registration form for 'CIEON INVENTORY'. At the top left is a blue 'Back' button. The form itself is white and centered. It features the CIEON logo (an orange circle with a white 'E' shape) and the text 'CIEON INVENTORY'. Below this are input fields for 'Firstname', 'Surname', 'Email', and 'Password'. A red error message below the password field reads: '*Password must be at least 6 characters/number but not more than 20'. At the bottom of the form is a blue button labeled 'TEACHER'.

Figure 4.5 The registration form of teacher

The screenshot shows the 'Edit Profile' page. At the top, there is a navigation bar with the CIEON logo, the text 'CIEON Inventory Management', and a dropdown menu labeled 'Features' with 'cie' selected. The main heading is 'Edit Profile'. Below it are several input fields: 'Firstname' with the value 'cio', 'Surname' with the value 'kmitl', 'Email' with the value '60011228@kmitl.ac.th', and 'Telephone number' with the value '095 576 2894'. There is also a field for 'Amount of items that user can reserve and borrow' with the value '6'. At the bottom is a blue 'save' button.

Figure 4.6 The edit profile page

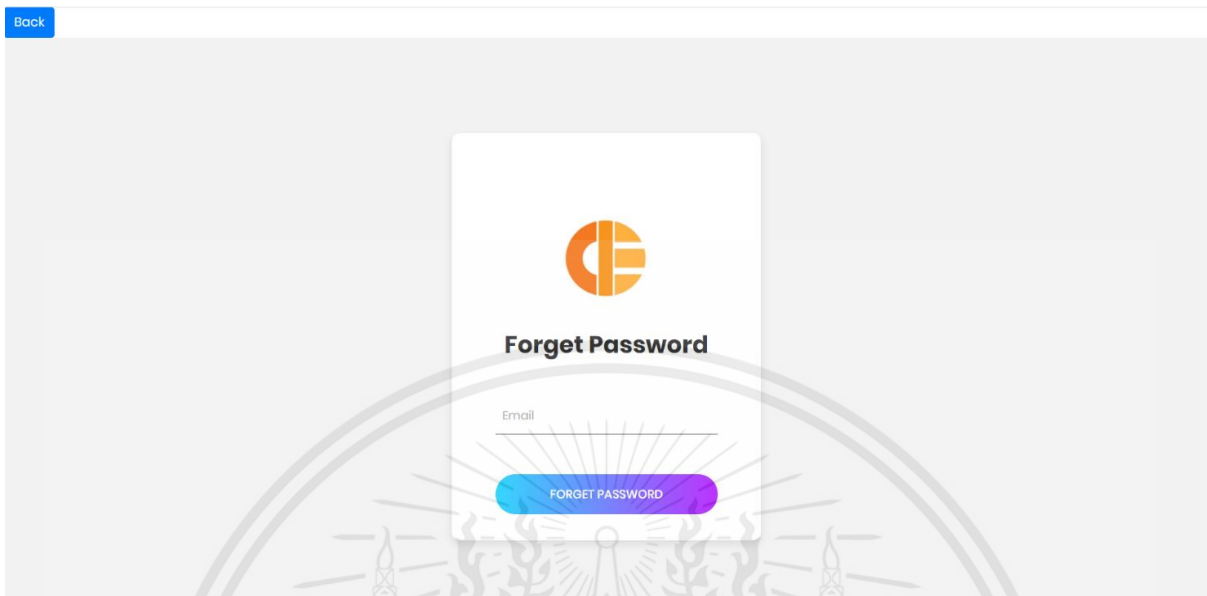

Figure 4.7 The forget password page

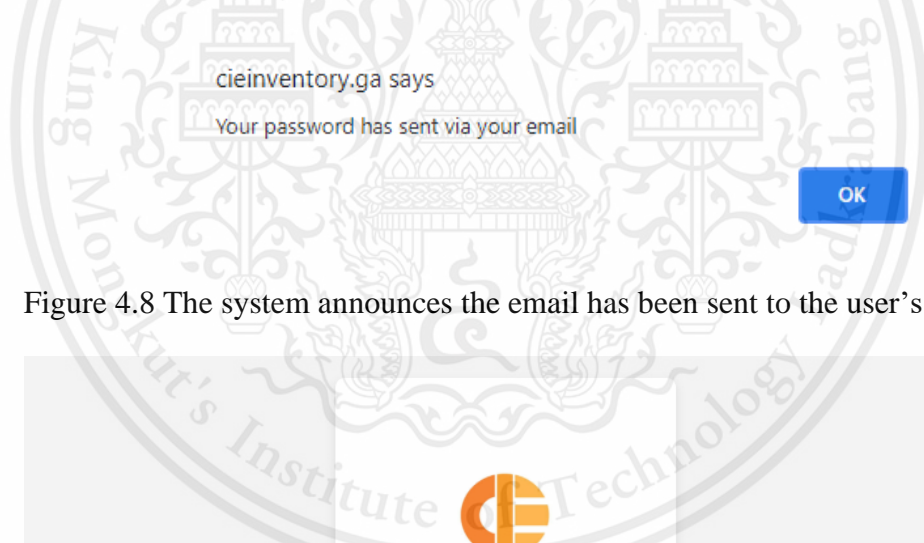

Figure 4.8 The system announces the email has been sent to the user's email

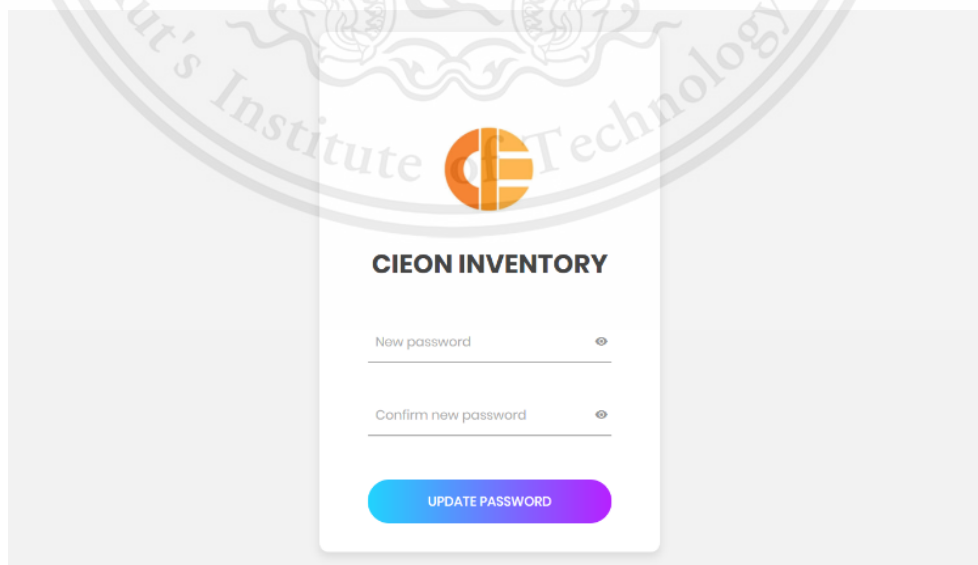
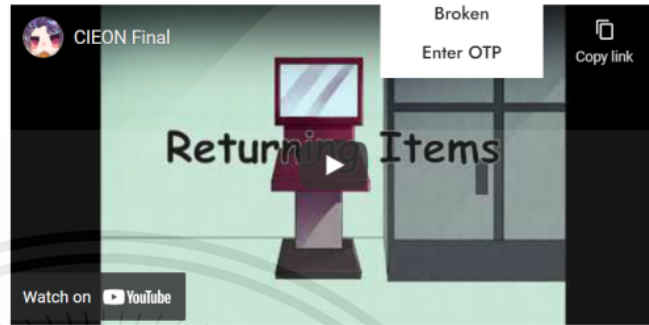

Figure 4.9 The change password page



Welcome to CIEON Inventory Management System

CIEON Inventory management system is a smart system developed to assist with stock management systems by implementing a self-borrowing and a self-returning process.



- Borrow
- Return
- Broken
- Enter OTP
- Copy link

Features



Figure 4.10 The offline homepage

Features



 <p>Reserve</p>	 <p>Extend</p>	 <p>Lost</p>
<p>Reserve</p> <p>User can reserve the items through online. After user choose the items and submit the information. User will receive OTP via E-mail and fill that OTP on the panel in front of the locker to take the items inside the locker.</p>	<p>Extend Date/Time</p> <p>User can extend the return date of items before the deadline 1 day.</p>	<p>Lost</p> <p>User can declare the items and quantity of items that they lost through website. However, those user will receive a penalty and cannot use the system until the admin edit their penalty status.</p>

Figure 4.11 The online homepage



Figure 4.12 The admin homepage

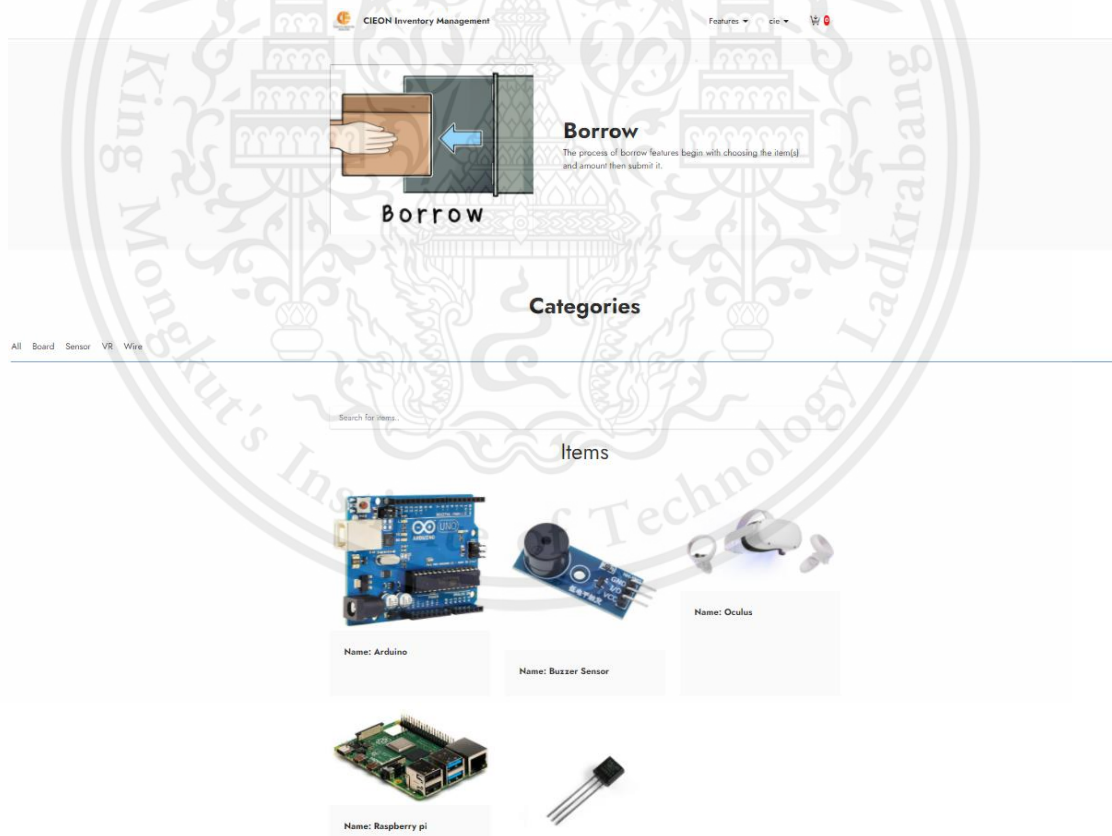

Figure 4.13 The borrow page

HDMI

Items



Name: HDMI

Amount: 2

Figure 4.14 Example of using search items



CIEON Inventory Management

Features

cie



Raspberry pi

Type: Board

Locker Number: 1

Amount in Stock: 2

1

Borrow

Items



Figure 4.15 Example of the item detail page

www.cieinventory.ga says

Borrow over limit

OK

Figure 4.16 The system alerts message “Borrow over limit”

cieinventory.ga says

Success

OK

Figure 4.17 The system alerts message “Success”

Borrow list



Name: Oculus

**Name:
Arduino**

**Return date:
2021-06-18**

**Return date:
2021-06-18**

Amount: 2

Amount: 1

**Name:
Temperature
Sensor**

**Return date:
2021-06-18**

Amount: 1

Borrow

Back

Figure 4.18 Example of the borrow items cart

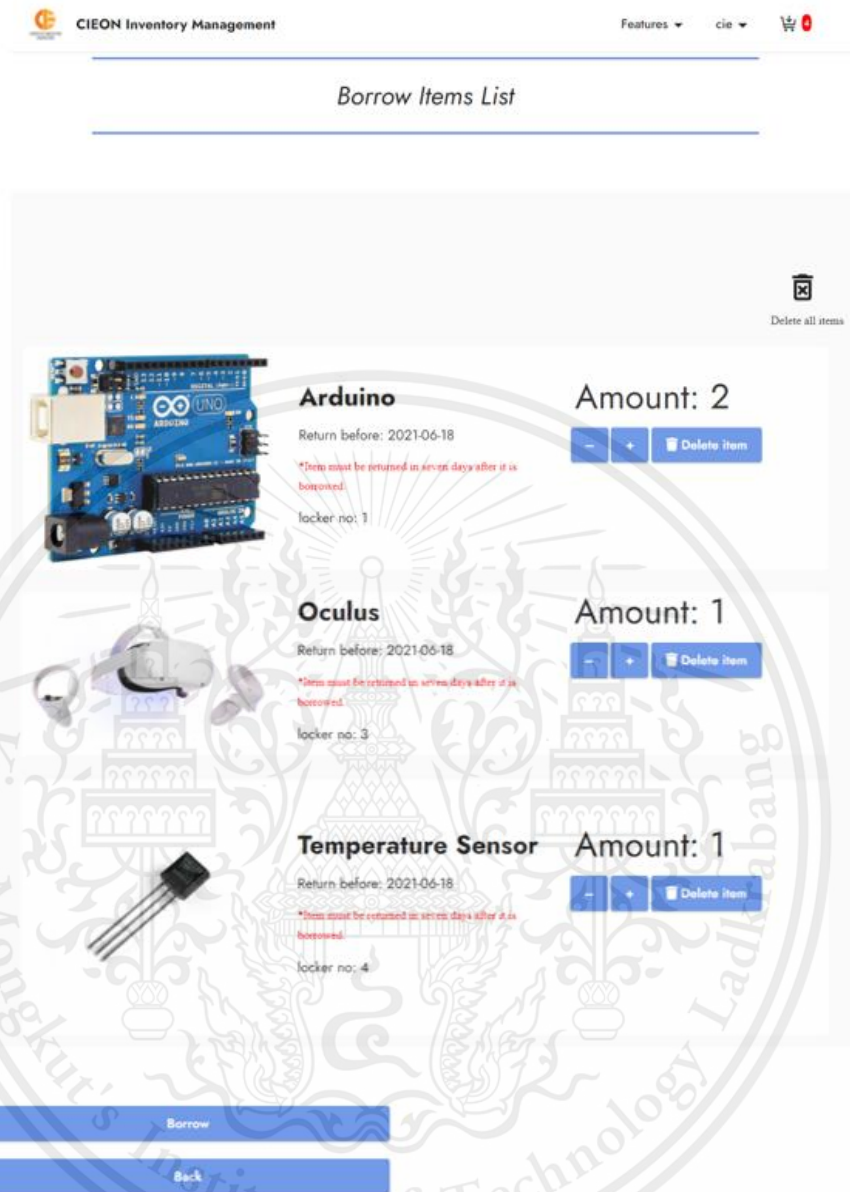

Figure 4.19 Example of the summarized page for the borrow feature

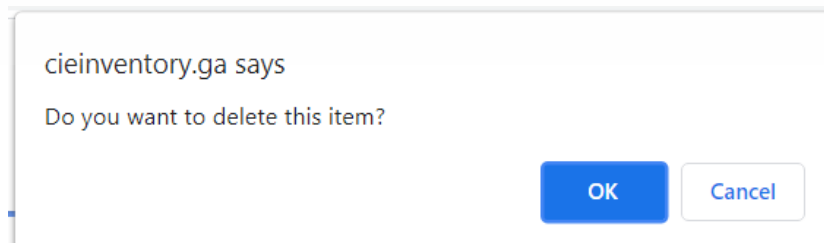

Figure 4.20 The system alerts message “Do you want to delete this item?”

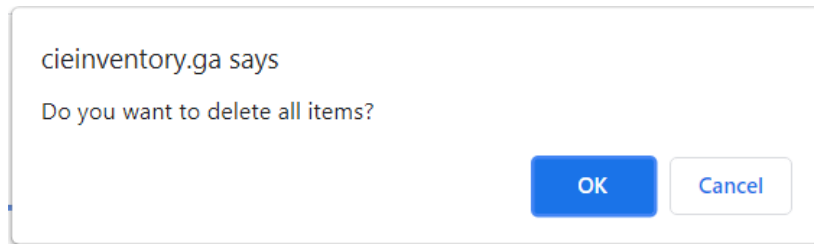

Figure 4.21 The system alerts message “Do you want to delete all items?”

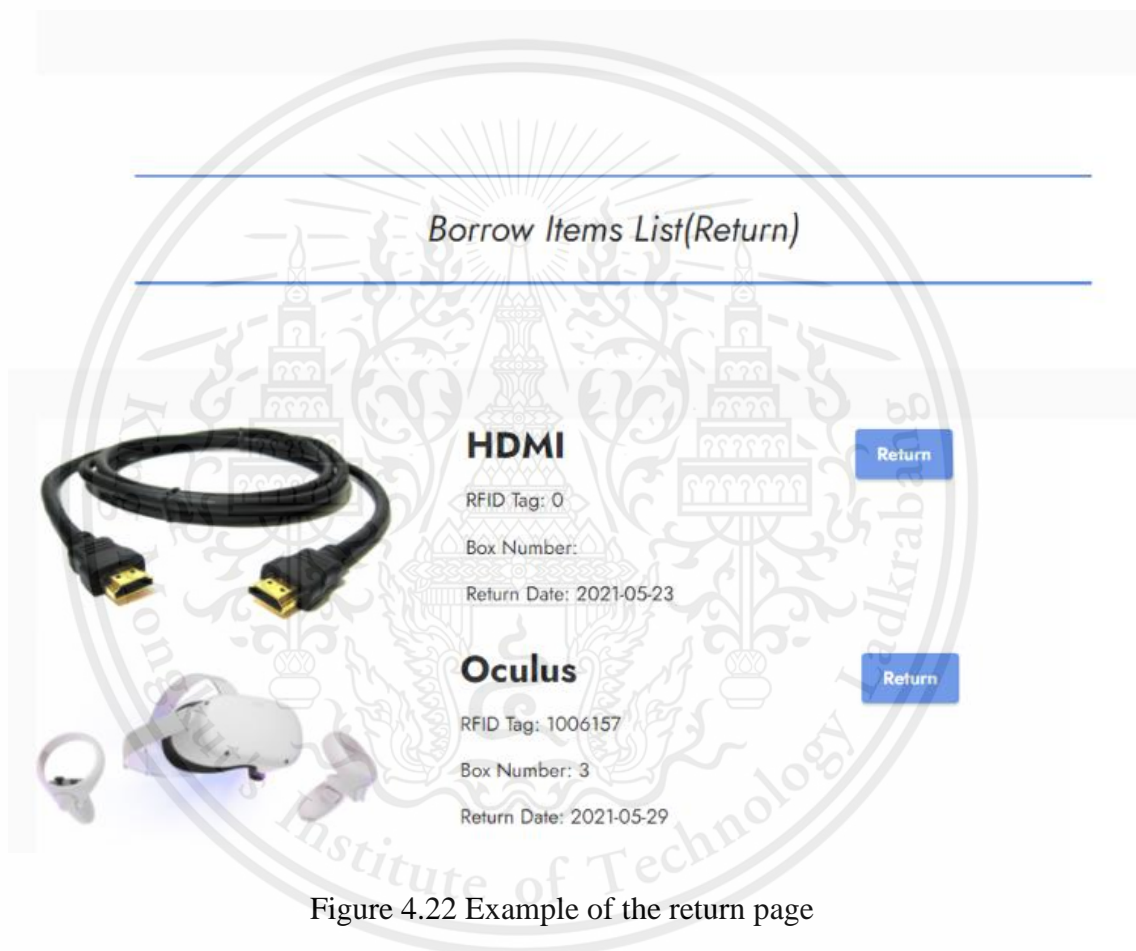

Figure 4.22 Example of the return page

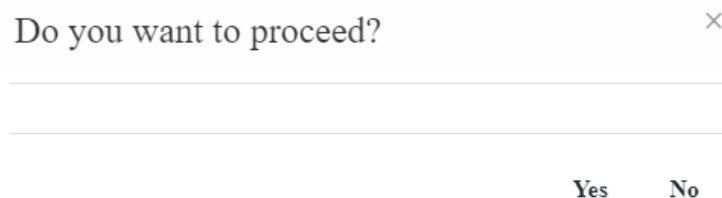

Figure 4.23 The system sends message “Do you want to proceed?”

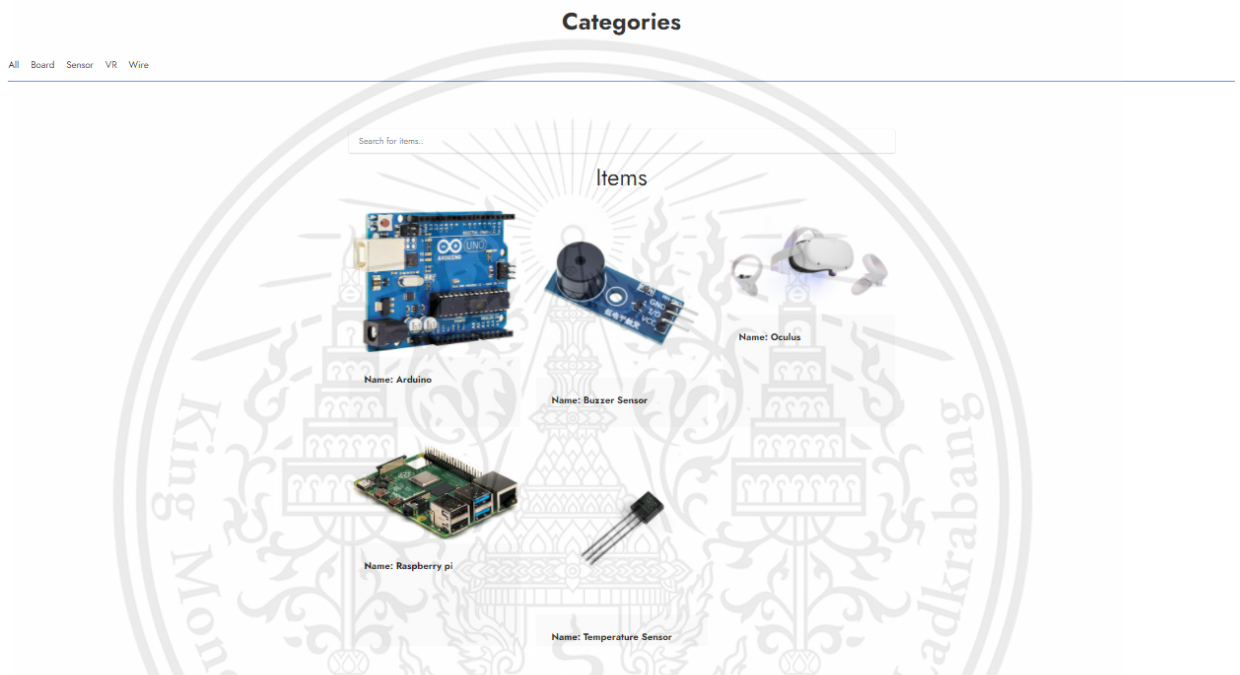
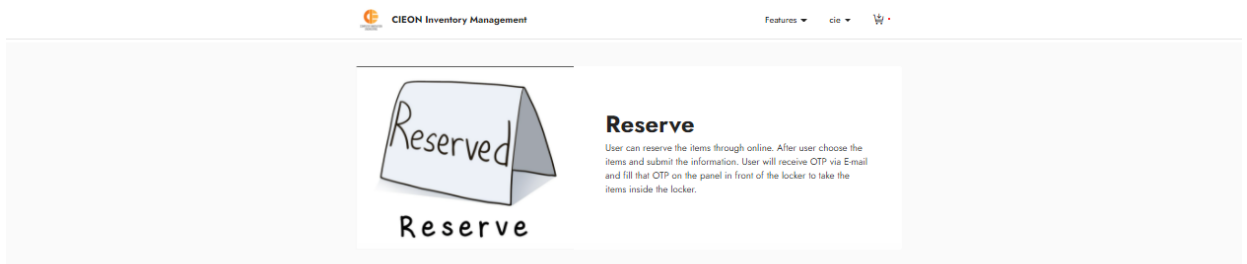

Figure 4.24 Example of the reserve page

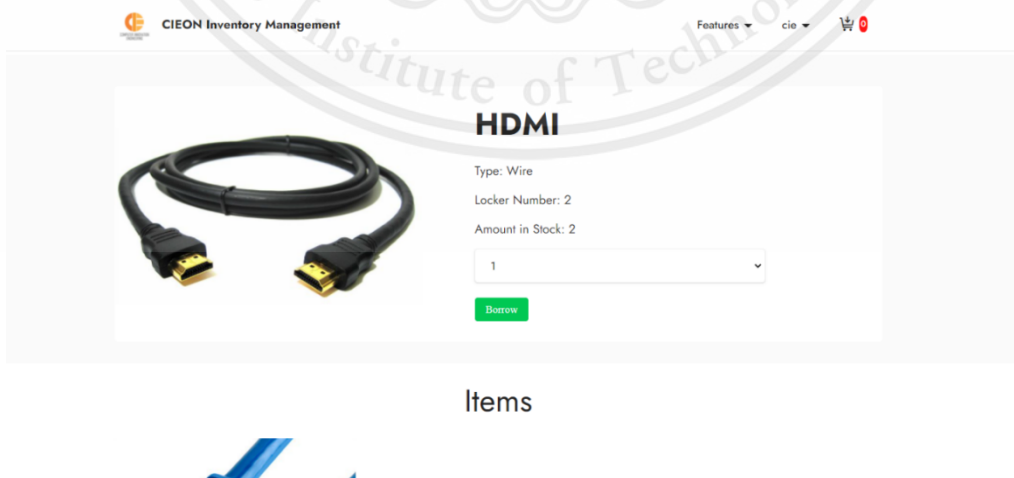

Figure 4.25 Example of the item detail page



Name:
Arduino
Pickup Date:
2021-06-12
Amount: 1



Name: Buzzer
Sensor
Pickup Date:
2021-06-12
Amount: 1



Name:
Raspberry pi
Pickup Date:
2021-06-12
Amount: 2

Reserve Back

Figure 4.26 Example of the reserve cart

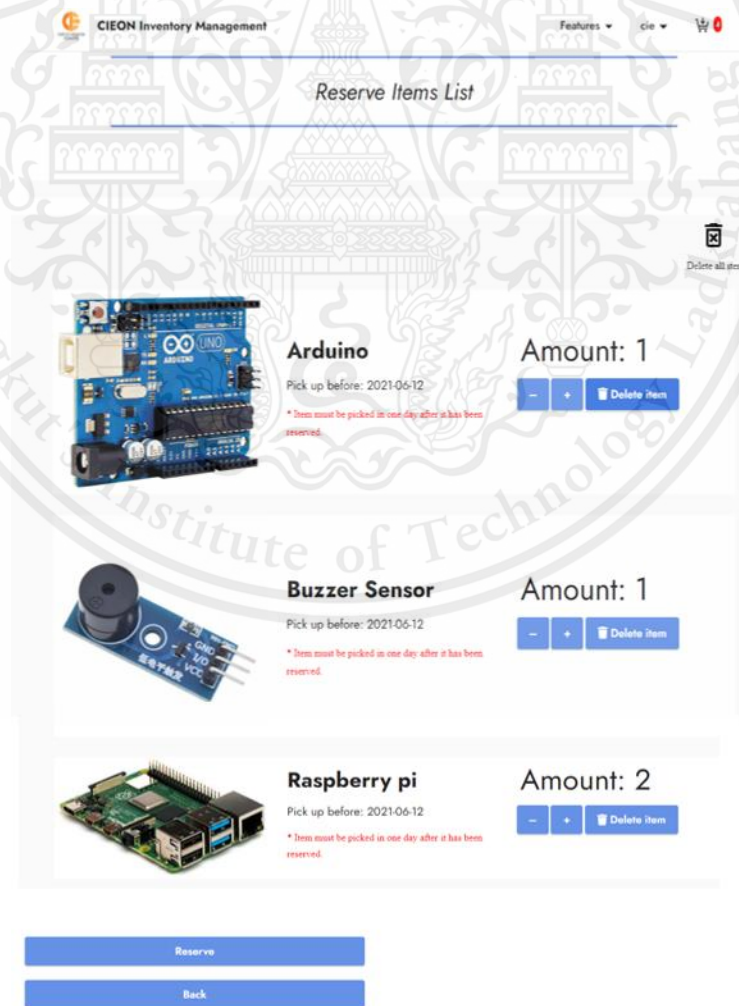

Figure 4.27 Example of the summarized page for the reserve feature

This material is reserved for educational use only, not allowed for commercial use.

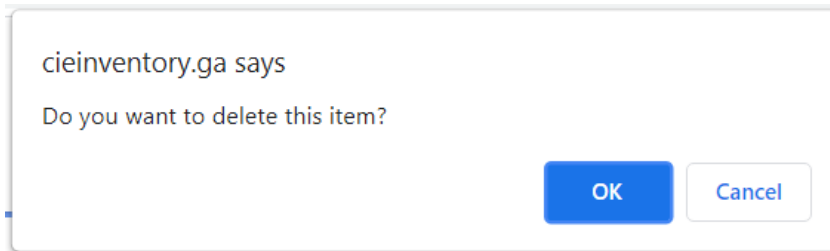

Figure 4.28 The system alerts message “Do you want to delete this item?”

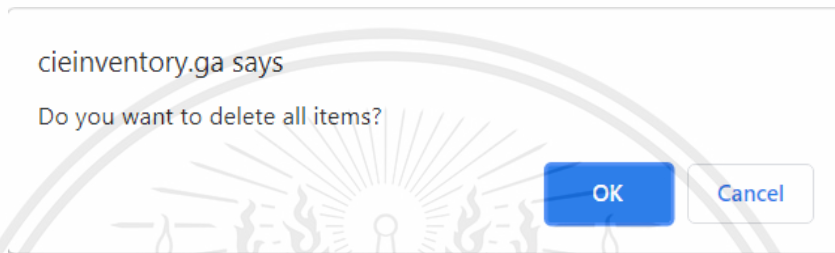

Figure 4.29 The system alerts message “Do you want to delete all items?”



Figure 4.30 Example of the broken page

Broken Detail



Broken

Cancel

Logout

Figure 4.31 The broken explanation detail box

Warning! You currently have penalty status please contact admin at HM 604

Welcome to CIEON Inventory Management System

CIEON Inventory management system is a smart system developed to assist with stock management systems by implementing a self-borrowing and a self-returning process.



Features

Figure 4.32 Example of the penalty page

Borrow Items List(Lost)



Arduino

Lost

RFID Tag: 2650642

Box Number: 1

Return Date: 2021-05-30

Figure 4.33 Example of the lost page

Do you want to proceed?



Yes No

Figure 4.34 The system sends message “Do you want to proceed?”

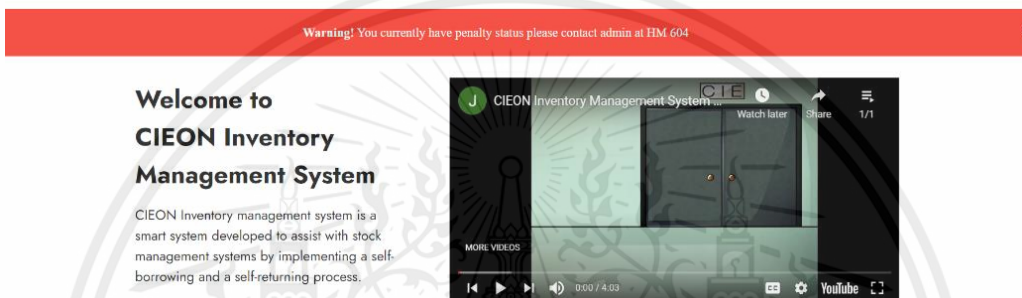

Figure 4.35 Example of the penalty page

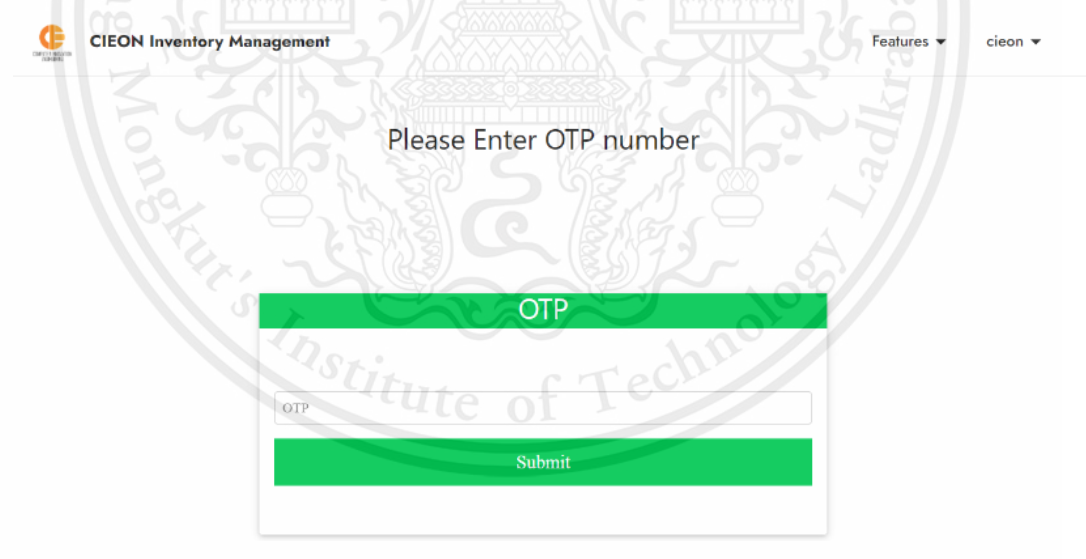

Figure 4.36 The enter OTP page

cieinventory.ga says

Your OTP is not correct more than 3 times and it will expire soon. Please use the Borrow feature instead.

OK

Figure 4.37 The system pops up after filling the OTP number incorrectly 3 times
This material is reserved for educational use only, not allowed for commercial use.

Borrow Items List



Figure 4.38 The extend date/time page

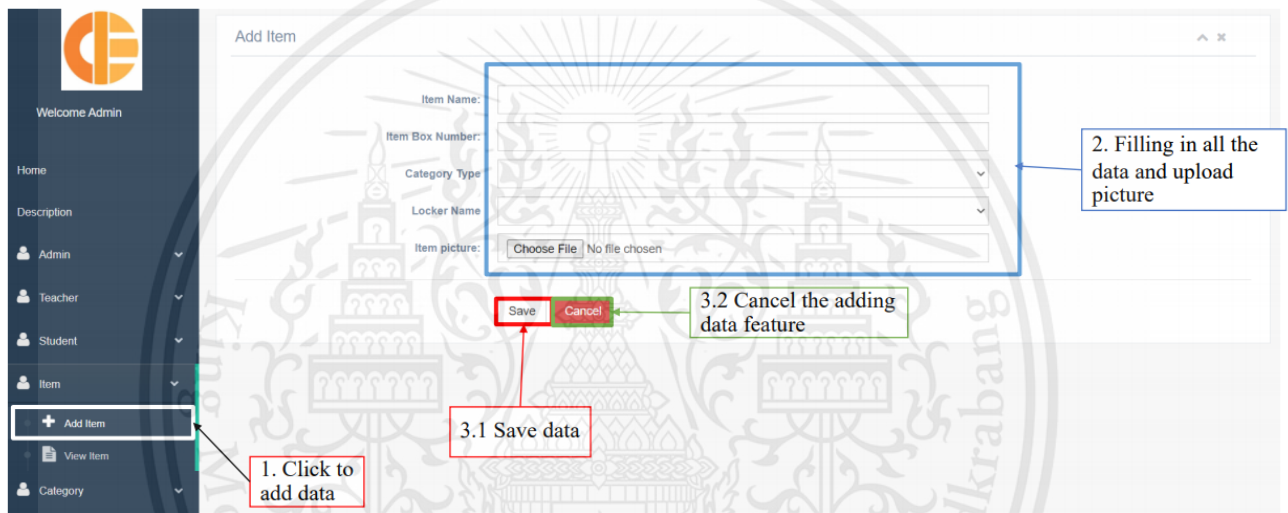

Figure 4.39 Example of the add data page

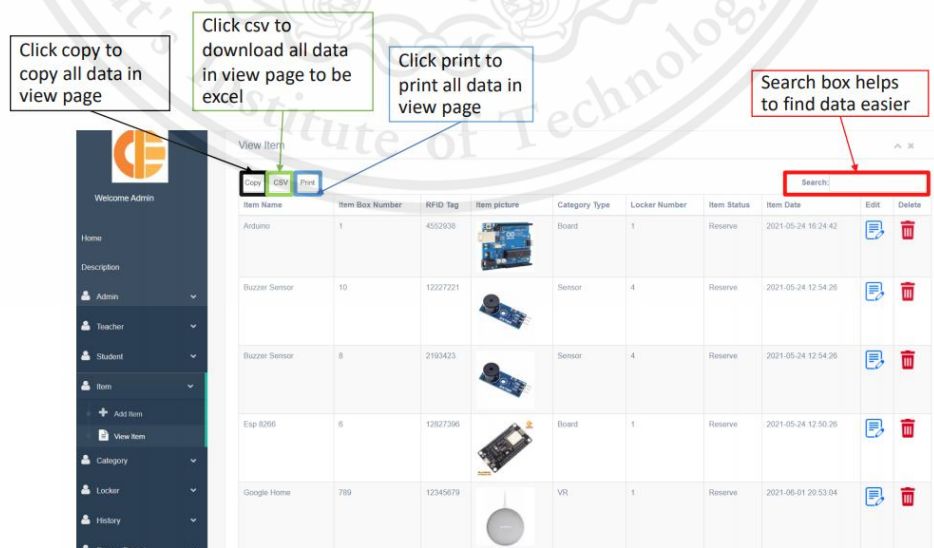

Figure 4.40 Example of the view data page on the top of the page

This material is reserved for educational use only, not allowed for commercial use.



Figure 4.41 Example of the view data page on the bottom of the page

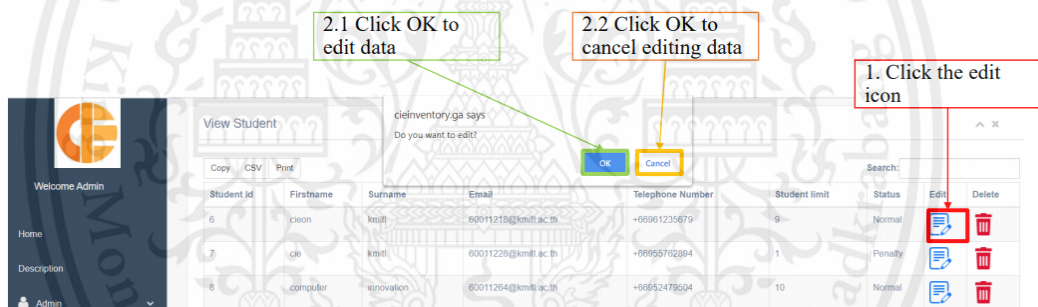

Figure 4.42 Example of the view data page after clicking the edit icon

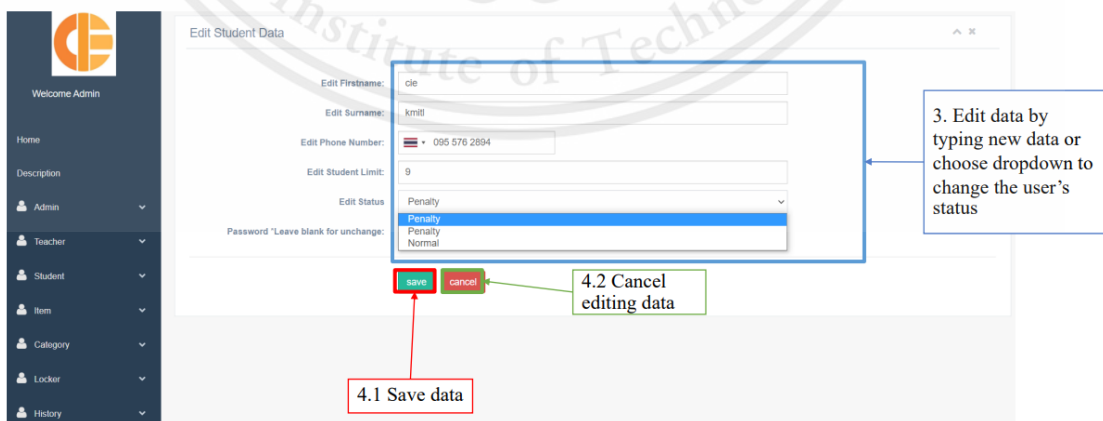

Figure 4.43 Example of the edit data page



Figure 4.44 Example of the delete data page

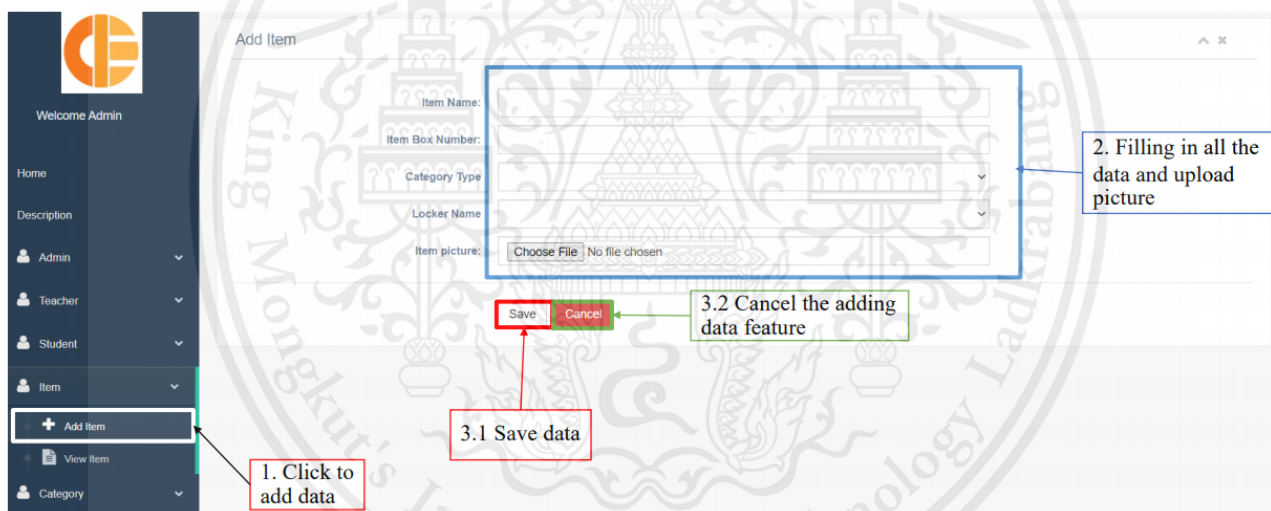

Figure 4.45 The page of adding items



Figure 4.46 The view item page after adding items without scanning the RFID tag

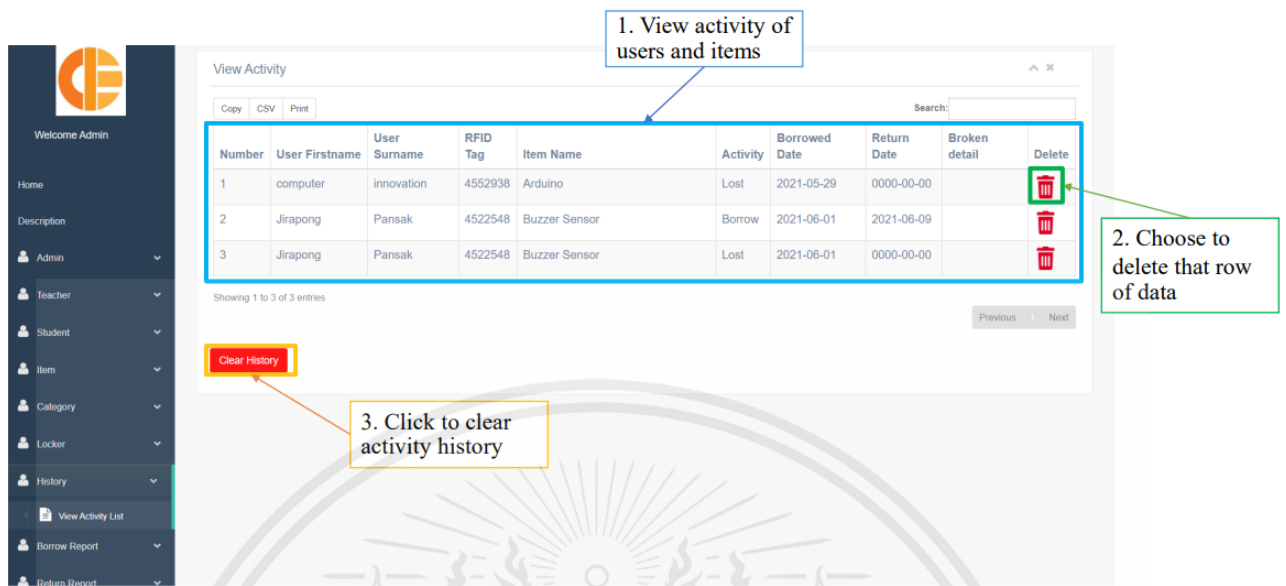

Figure 4.47 The view activity page of the history feature

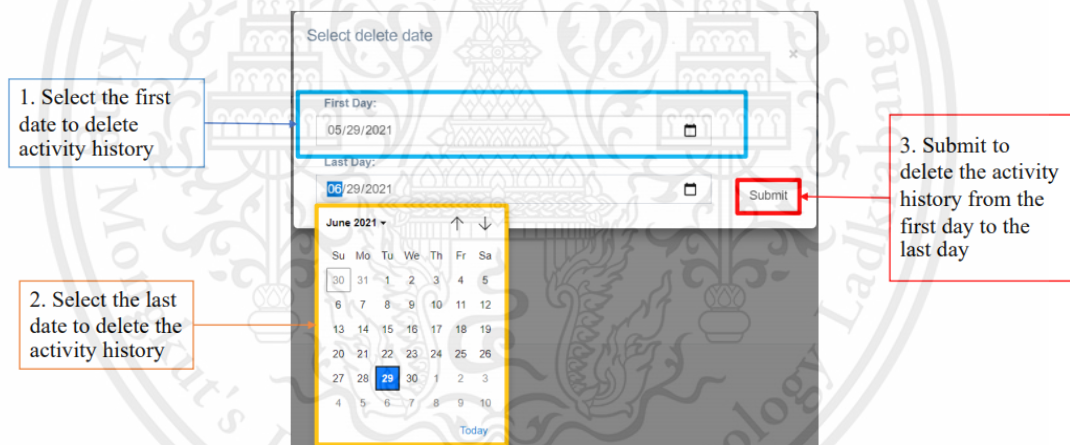

Figure 4.48 The clear history page

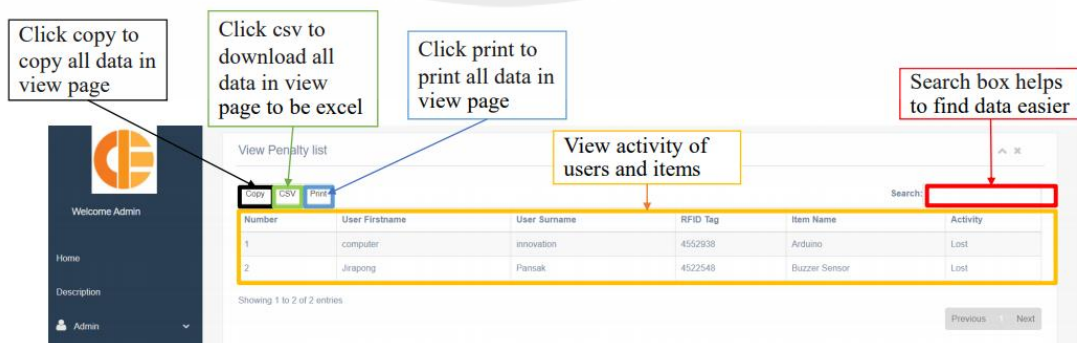

Figure 4.49 Example of report page

Lockers

Admin can click the button to open the locker door

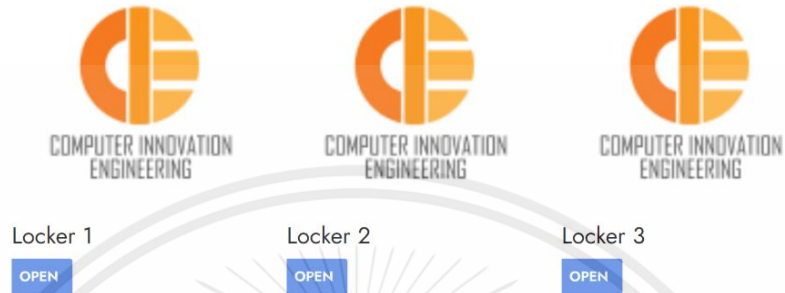

Figure 4.50 Controlling locker page

4.2.3 Hardware System

The hardware system describes the process step by step on the hardware part that controls the system with the image support to make the explanation clear in each part.

4.2.3.1 Locker part

This part will control the solenoid to open or close the locker door, alarm sensor, and door sensor by using a Raspberry Pi. The system will connect all hardware as shown in figure 4.51. Figure 4.52 shows that the wires from magnetic solenoid and buzzer sensor connect to 5V relay modules. Wires for door sensor connect to Raspberry Pi via pin. Figure 4.53 shows that magnetic solenoid and door sensor stick at the top of each locker door.

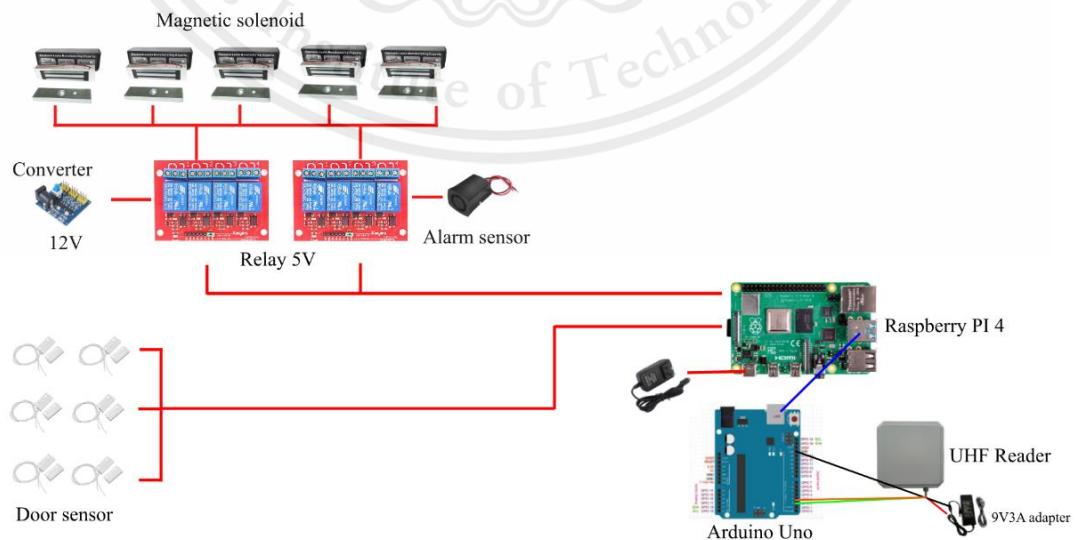

Figure 4.51 Overall locker system

This material is reserved for educational use only, not allowed for commercial use.

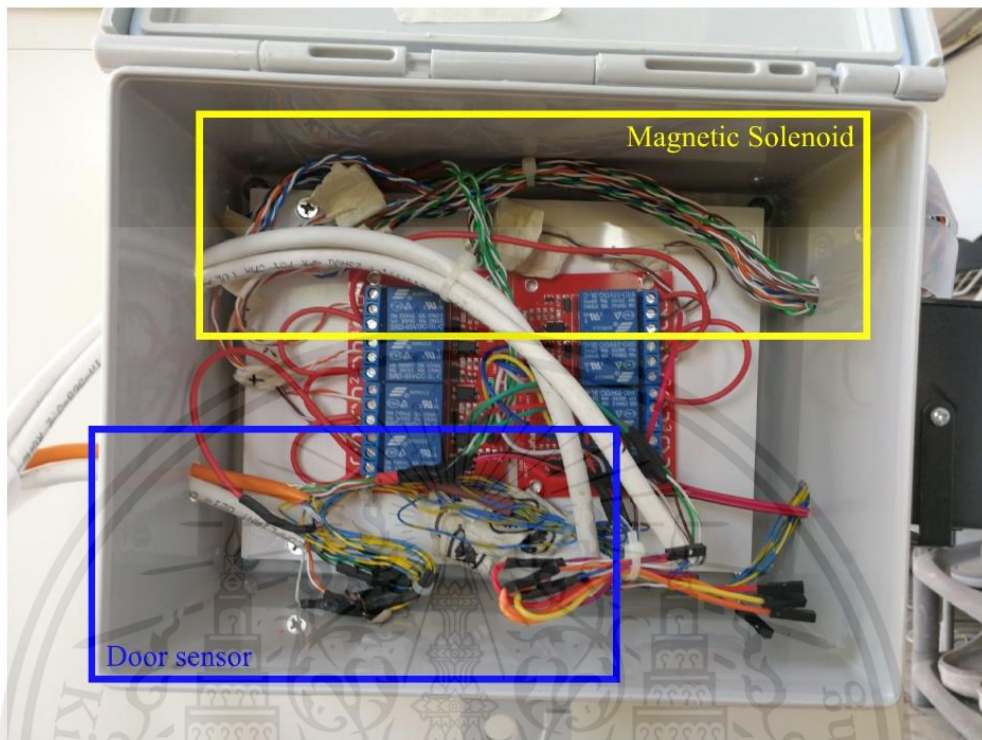

Figure 4.52 Outside locker system

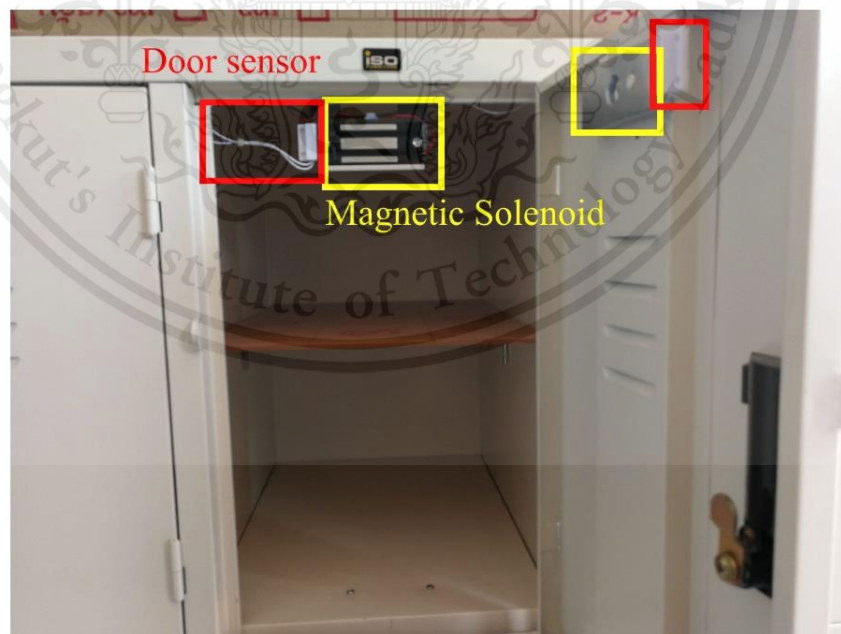

Figure 4.53 Inside the locker system

4.2.3.2 Panel part

This part shows the process to use the offline website on the screen on panel. At the back of the panel, there is an RFID system to scan the RFID tags. Figure 4.54 shows that tablet is located on the top of the panel. Figure 4.55 shows that the UHF reader, Raspberry Pi, and Arduino Uno are located at the back of the panel. The UHF reader connects to Arduino Uno via Wiegand port and Arduino Uno connects to Raspberry Pi via serial port.

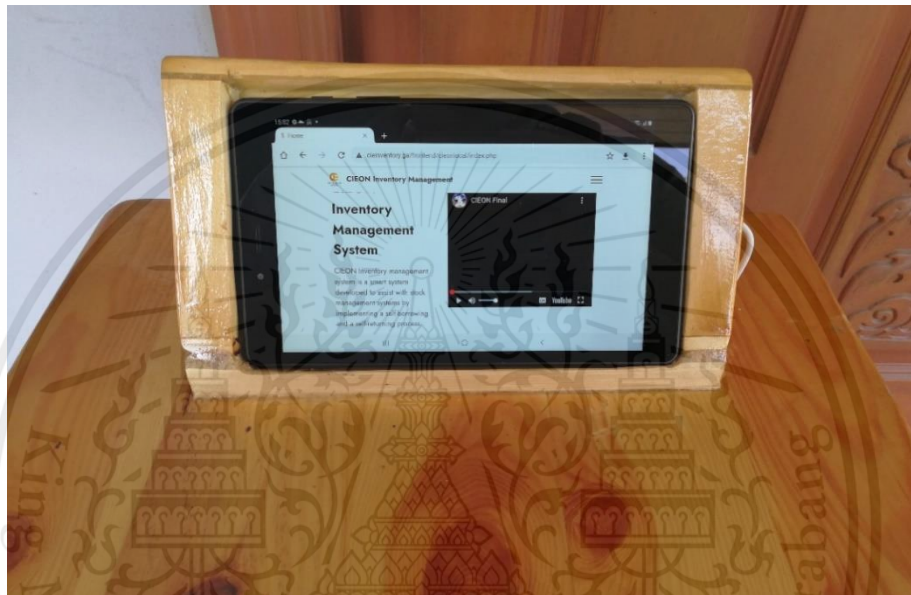

Figure 4.54 Screen on panel

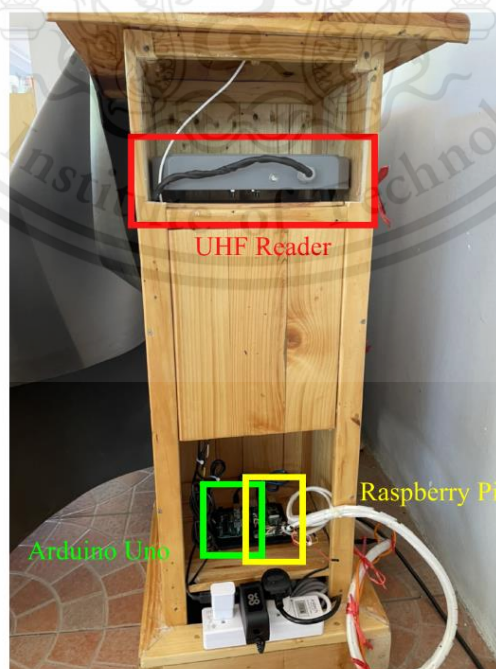

Figure 4.55 RFID system

This material is reserved for educational use only, not allowed for commercial use.

4.2.3.3 Door part

This part will check the items which are not borrowed items, and the alarm will alert the user if the user tries to steal the items. The system will connect all hardware as shown in figure 4.56 and figure 4.57.

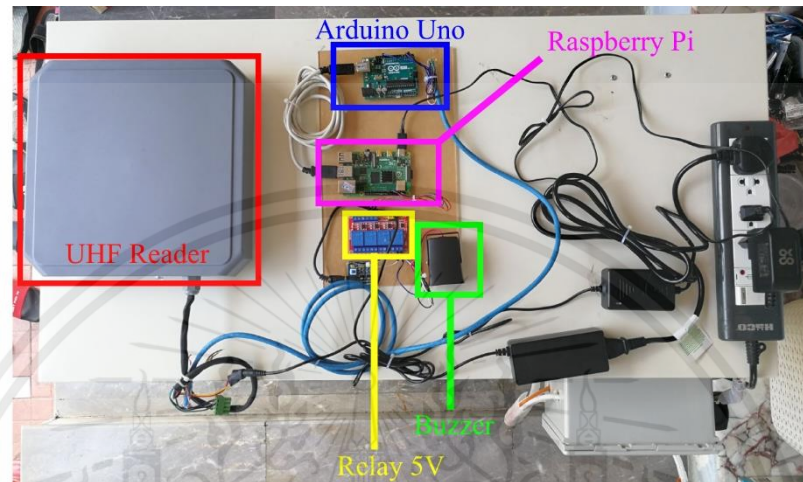

Figure 4.56 Door system

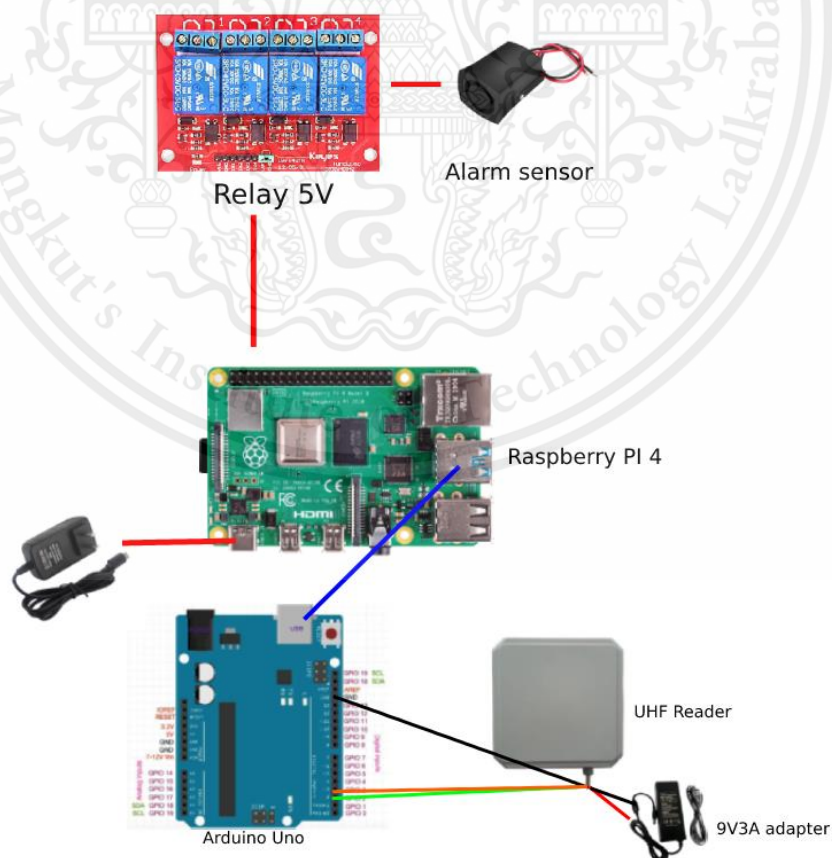

Figure 4.57 Overall door system

This material is reserved for educational use only, not allowed for commercial use.

4.2.3.4 Item box part

This part shows the items stored in individual boxes and separated into different categories by putting it in the lockers as shown in figure 4.58. Figure 4.59 shows the category types. In figure 4.60 displays that RFID tag, which is stuck below the box and the box number is stuck on the side of the item's box.

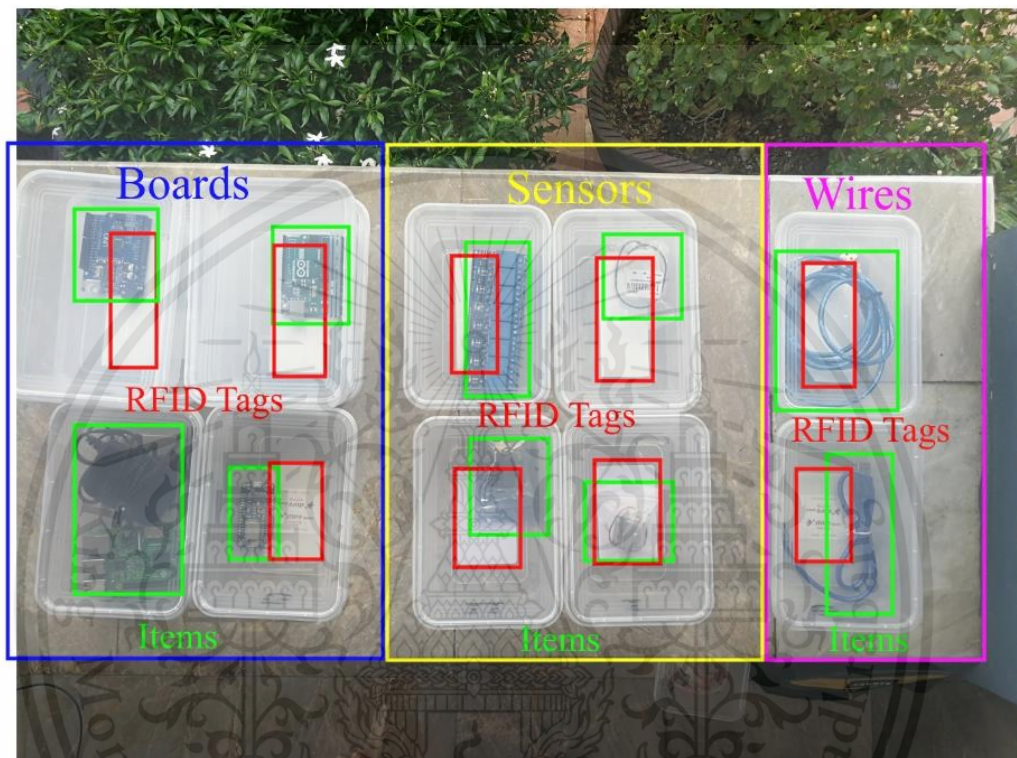

Figure 4.58 Example of box and item

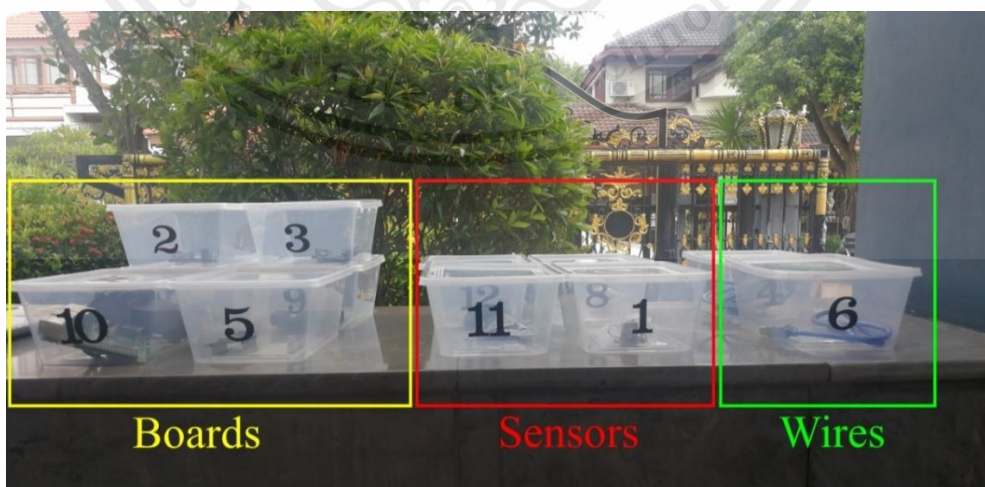

Figure 4.59 Example of box number separated by category type



Figure 4.60 Example of box number and RFID tags

4.3 Evaluation

There are three main users: teacher, student, and staff of whom only the staffs are tested to be admins of this system.

There are 38 persons who gave the feedback of this project. In figure 4.61, it shows the percentage of people who tested the system in each role. Students who took this testing are students who are studying in the field of Computer Innovation Engineering in Year 2 and Year 3 of which the number and percentage of students are displayed in figure 4.62. The teachers and staff who work at CIE are the group who gave the feedback results. This survey separates the questionnaire into two parts. First is the overall system questions that lets every user gives the score and the other is the questionnaire that only administrators can give the score.

What is your occupation?(อาชีพของคุณคืออะไร)

คำตอบ 39 ข้อ

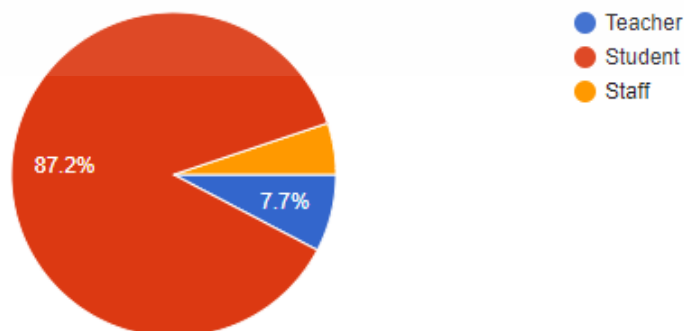

Figure 4.61 The percentage of users who test the system in each role

This material is reserved for educational use only, not allowed for commercial use.

Student year

คำตอบ 34 ข้อ

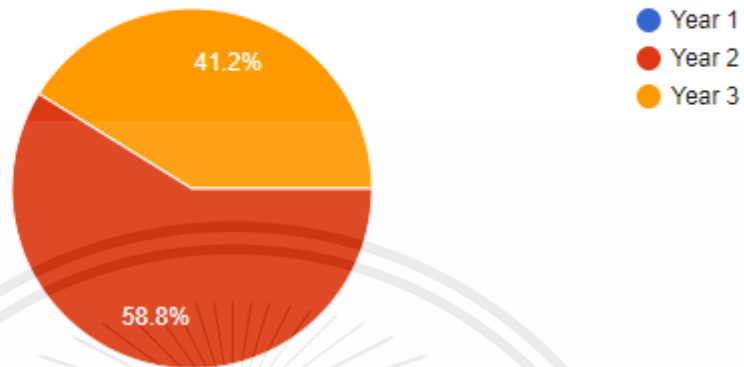

Figure 4.62 The percentage of students who test the system

These following results are the feedback from the survey testing in the overall system for every user who tested the system:

1. According to figure 4.63, it shows the question and the feedback score. The average score of the system that shows it is easy to use, convenient, and user-friendly is approximately 3.92.

1. The system is easy to use, convenient, and user-friendly each button has clear meaning and easily make user understand. For example, login button is use for login, forget password button use for reset user password. (ระบบใช้งานง่าย สะดวก เป็นมิตรกับผู้ใช้โดยแต่ละปุ่มมีความหมายที่ชัดเจนและทำให้สามารถเข้าใจได้โดยง่ายยกตัวอย่างเช่น ปุ่ม login ใช้เพื่อการ login เข้าสู่ระบบ, ปุ่ม forget password ใช้เพื่อรีเซ็ต password ของผู้ใช้งาน)

คำตอบ 39 ข้อ

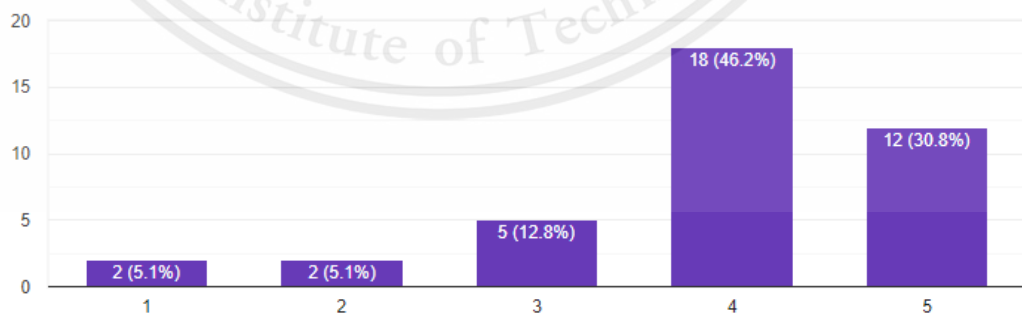

Figure 4.63 The scores of question no. 1

2. According to figure 4.64, it shows the question and the feedback score. The average score of the clarity explanation of various components on the system screen is approximately 4.05.

This material is reserved for educational use only, not allowed for commercial use.

2. Clarity of explanation of various components on the system screen. For example, if user type wrong email or password the system will show "login fail" message.(ความชัดเจนของคำอธิบาย ส่วนประกอบต่าง ๆ บนหน้าจอของระบบ ยกตัวอย่างเช่นถ้าผู้ใช้งานกรอกอีเมลหรือพาสเวิร์ดผิดระบบจะทำการแจ้งเตือนว่าคุณล็อกอินไม่สำเร็จ)

คำตอบ 38 ข้อ

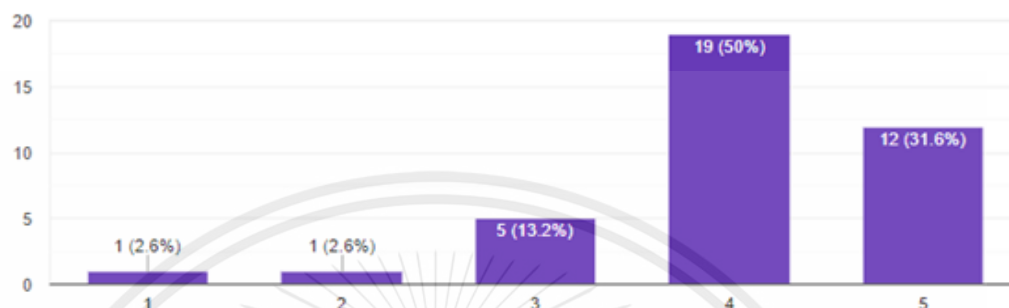

Figure 4.64 The scores of question no. 2

3. According to figure 4.65, it shows the question and the feedback score. The average score of the system that has a fast response processing speed is approximately 3.76.

3. The system has a fast respond processing speed such as after user successfully reserve items system will immediately logout for user with a message 'success'.(ระบบมีการประมวลผลที่รวดเร็ว เช่น หลังจากที่ผู้ใช้งานทำการจองเรียบร้อยแล้วระบบจะทำการล็อกเอาต์ออกในทันทีและแจ้งเตือนว่าจองสำเร็จ)

คำตอบ 39 ข้อ

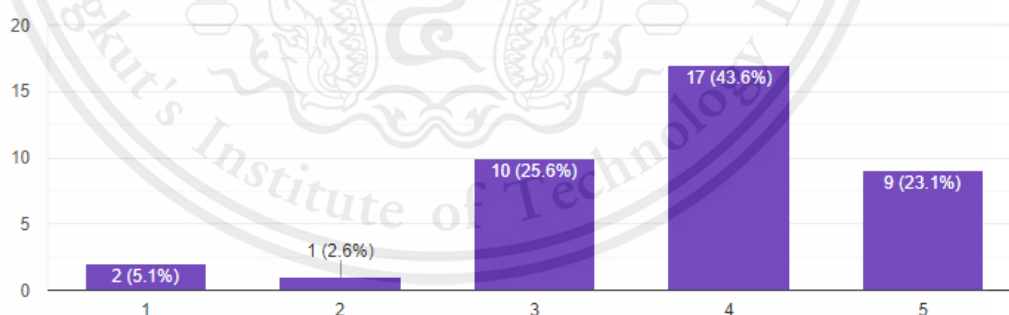

Figure 4.65 The scores of question no. 3

4. According to figure 4.66, it shows the question and the feedback score. The average score of the system provides accurate notification when wrong information is entered is approximately 4.08.

4. The system provides accurate notifications when wrong information is entered such as in login page if user type in email with out @ sign system will show message "Email need @ sign".(ระบบมีการแจ้งเตือนที่ถูกต้องเมื่อมีการกรอกข้อมูลผิด ตัวอย่างเช่นในหน้า login ถ้าผู้ใช้งานไม่ใส่@ในช่องของemailระบบจะทำการแจ้งเตือนให้ผู้ใช้งานใส่ @ลงไปในemail)

คำตอบ 39 ข้อ

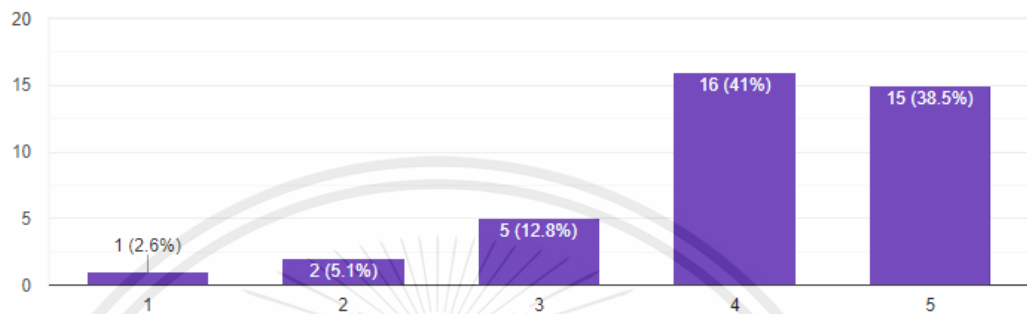

Figure 4.66 The scores of question no. 4

5. According to figure 4.67, it shows the question and the feedback score. The average score of the system will display results that are accurate and meet the needs of users is approximately 4.08.

5. The system will display results that are accurate and meet the needs of users. For example, If user reserve items after finish process user should receive email with same exact information(ระบบมีการแสดงผลรายงานที่ถูกต้องและตรงกับความต้องการของผู้ใช้ ยกตัวอย่างเช่นหลังจากที่ผู้ใช้งานได้ดำเนินการจองอุปกรณ์ หลังจากเสร็จสิ้นกระบวนการผู้ใช้งานจะได้รับemailแจ้งเตือนเกี่ยวกับของตามที่คุณได้ทำการจองไป)

คำตอบ 39 ข้อ

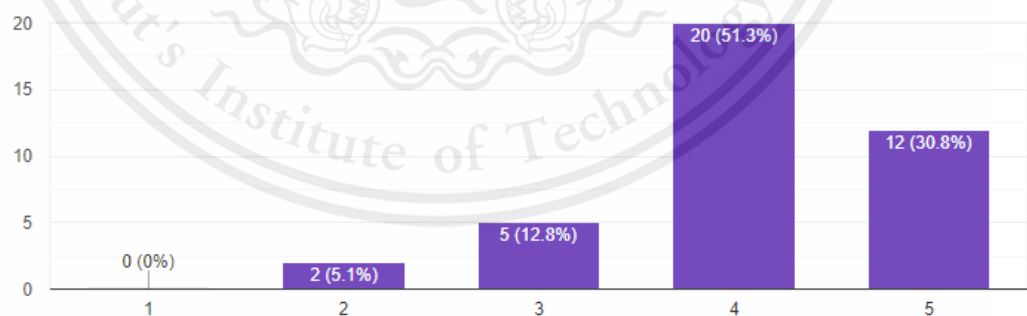

Figure 4.67 The scores of question no. 5

6. According to figure 4.68, it shows the question and the feedback score. The average score of the system can help user reduce process for borrow and return items compare with present process which do not have this system is approximately 3.64.

6. This system can help user reduce process for borrow and return items compare with present process which don't have this system. (ระบบนี้สามารถช่วยลดขั้นตอนในการจัดการการยืมและคืนของผู้ใช้งานเทียบกับปัจจุบันที่ไม่มีระบบนี้)

คำตอบ 39 ข้อ

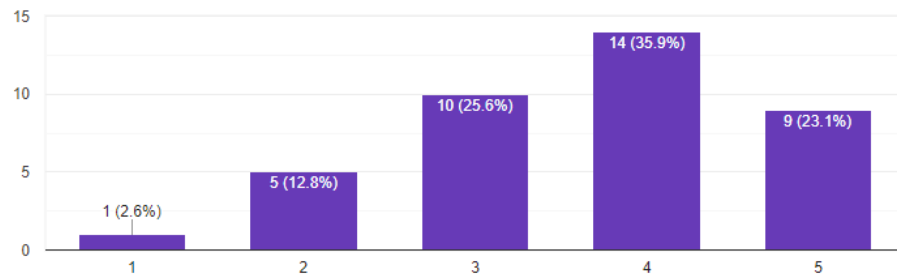

Figure 4.68 The scores of question no. 6

7. According to figure 4.69, it shows the question and the feedback score. The average score of users who agree to the use of this system is approximately 3.90.

7. You agree to the use of this system. (คุณเห็นด้วยกับการใช้ระบบนี้)

คำตอบ 39 ข้อ

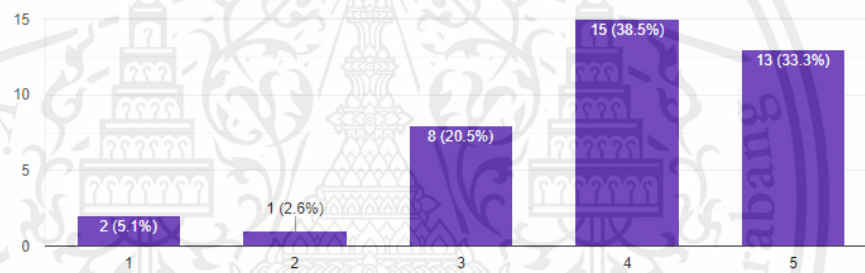

Figure 4.69 The scores of question no. 7

8. According to figure 4.70, it shows the question and the feedback score. The average score of users who agree to recommend this system to others is approximately 3.87.

8. According to no. 7, after using this system, would you agree to recommend this system to others? (จากข้อ 8 ถ้าใช้ระบบนี้แล้ว คุณเห็นด้วยมั๊ยที่จะแนะนำระบบนี้ให้คนอื่นใช้)

คำตอบ 39 ข้อ

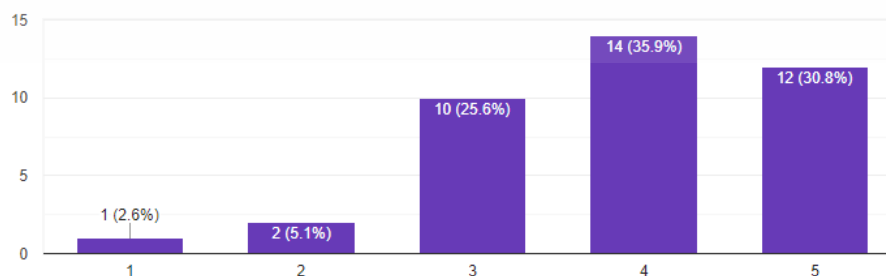

Figure 4.70 The scores of question no. 8

These following feedback results is the score from the questionnaire who tested it as an admin:

1. According to figure 4.71, it shows the question and the feedback score. The average score that it is easy to use the data management system is 4.0.

1. Easy to use data management system. For example, the system has buttons or icons that easily to stand such as add data (ระบบในการจัดการข้อมูลใช้งานง่าย ตัวอย่างเช่นระบบมีปุ่มหรือสัญลักษณ์ที่เข้าใจง่ายเช่นสัญลักษณ์ตัวบวกซึ่งใช้ในการเพิ่มข้อมูล)

คำตอบ 2 ข้อ

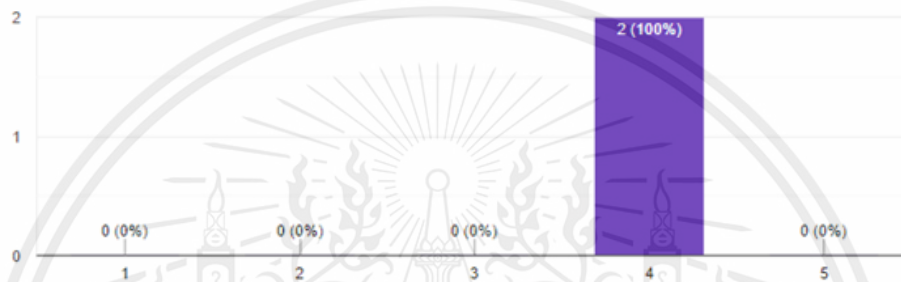

Figure 4.71 The scores of question no. 1 for admin

2. According to figure 4.72, it shows the question and the feedback score. The average score of admins that are able to handle information accurately in adding data, editing data, viewing data, and deleting data is 4.5.

2. Able to handle information accurately in adding data, editing data, viewing data and deleting data. For example, after adding data, the new data can be view on viewing data page. (สามารถจัดการข้อมูลได้อย่างถูกต้องในการเพิ่มข้อมูล ดูข้อมูล แก้ไขข้อมูลและลบข้อมูล ตัวอย่างเช่นเมื่อทำการเพิ่มข้อมูลใหม่แล้วผู้ใช้สามารถดูข้อมูลที่ถูกเพิ่มในหน้าดูข้อมูลได้)

คำตอบ 2 ข้อ

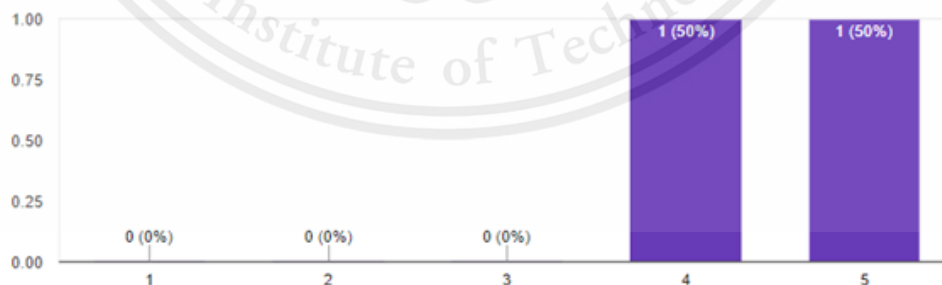

Figure 4.72 The scores of question no. 2 for admin

3. According to figure 4.73, it shows the question and the feedback score. The average score of admins that are able to track individual and item information accurately is 4.0.

3. Able to track individual and item information accurately. (สามารถติดตามข้อมูลเฉพาะบุคคลได้อย่างถูกต้อง)

คำตอบ 2 ข้อ

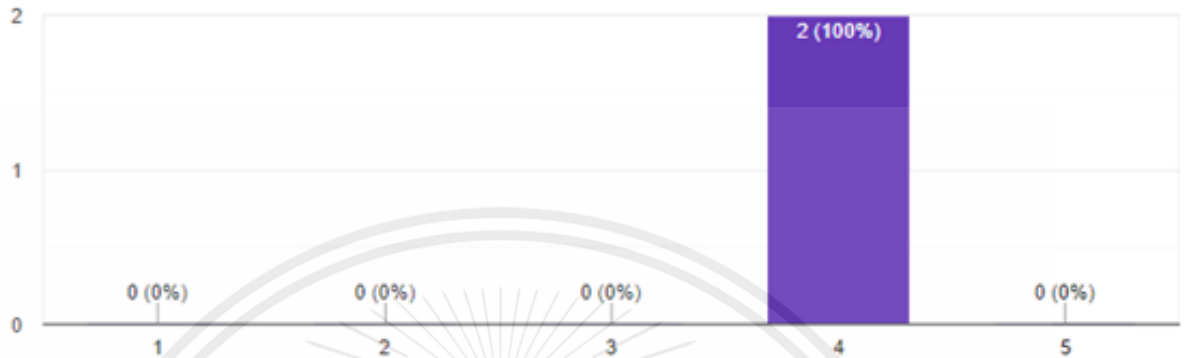

Figure 4.73 The scores of question no. 3 for admin

4. According to figure 4.74, it shows the question and the feedback score. The average score of the system can make the management of the goods more convenient is 4.5.

4. The system can make the management of the goods more convenient. (ระบบสามารถช่วยให้การบริหารจัดการของใน CIE ทำได้สะดวกมากขึ้น)

คำตอบ 2 ข้อ

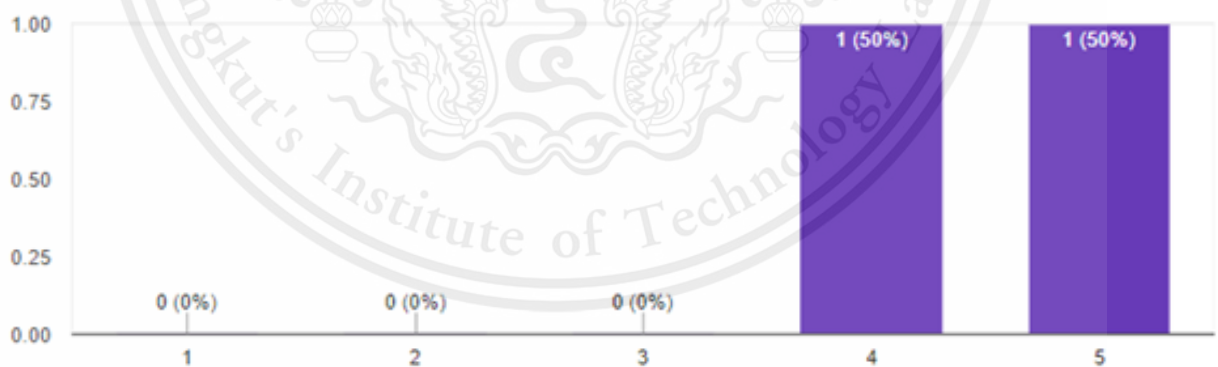

Figure 4.74 The scores of question no. 4 for admin

5. According to figure 4.75, it shows the question and the feedback score. The average score of the system can help the admin track lost and broken items more conveniently is 4.0.

5. System can help administer track lost and broken items more conveniently. (ระบบสามารถช่วยผู้ดูแลระบบติดตามของหายและพังได้สะดวกมากขึ้น)

คำตอบ 2 ข้อ

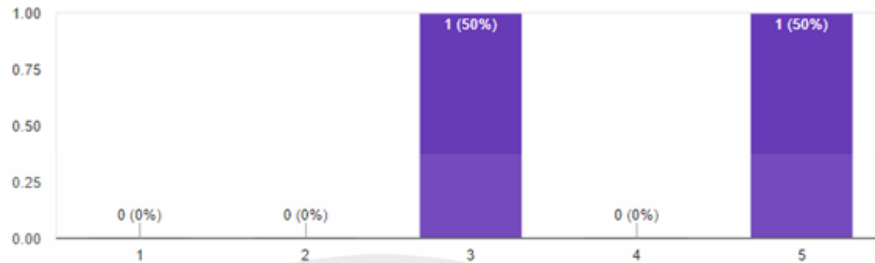

Figure 4.75 The scores of question no. 5 for admin

Overall, the overall score in this system that is calculated from adding the score of each question then divided by eight from eight questions in this survey is 3.91. For the admin feedback result, which consists of adding all the scores in each section then divided by five from five questions of the admin part survey is 4.2.

CHAPTER 5: CONCLUSION

5.1 Introduction

This chapter concludes the summary, conclusion, and discussion about the CIEON Inventory Management System. In section 5.2, we describe each chapter's summary. The conclusion contains the project with an explanation of the overall system and discussion.

This is a summary of each chapter, introduction, and summary.

- **Chapter 1** introduced the background, objective, scope, methodology and the expected outcome of this project.
- **Chapter 2** reviews the literature in related technology: software and hardware. The software and hardware tools that are used in this project were introduced and described. The potential for CIEON Inventory Management System tools was highlighted.
- **Chapter 3** describes the design of the business model, architecture, use case, and sequence diagrams. The separate functions of CIEON Inventory Management System that support the requirements were then described in more detail including the database and the business model.
- **Chapter 4** describes the implementation in the hardware and software of CIEON Inventory Management System.
- **Chapter 5** presented a series of tests that demonstrates the overall system.

5.2 Conclusion

The purpose of the project is to employ the technology in combination with a website to implement the notion of RFID detection and sensors as well as inventory directory checking. It will assist in reducing the chance of items being stolen or lost, as well as tracking the borrower and valuables.

CIEON Inventory Management System are 2 main websites separated to be online and offline websites beginning with the process on an online website. Reserve begins with reserving the items. After reserving the item, the system will update the new data to the database in the same way the system will generate the OTP number. And the OTP number will be sent to the user's email, and it will be used on the enter OTP feature on the offline website, which uses the tablet onsite panel to open the locker. An unexpired OTP number is required to use in the enter OTP feature to pick up the reserved items. The borrow feature works similar to the reserve feature but this feature has to be done on the offline website. Users have to choose the borrowed items and submit the borrowed items list. The locker that keeps the item on the borrowed list will open by checking the matching data on the database, which connects with JSON if the data is matched. The Raspberry Pi will then control the magnetic solenoid to open the locker

This material is reserved for educational use only, not allowed for commercial use.

door. Once the door lockers is opened, users need to scan items with the RFID reader. The Arduino Uno will get data from the RFID reader then the Arduino Uno will connect to the Raspberry Pi by serial port after that the Raspberry Pi will update the data to the database. Finally, the system will send the information of the borrowed items to user's email. The activities after the borrow process will fetch the borrowed data to declare or return items. The return and broken have to be done via the offline website, where the system fetches the borrowed data from the database. The return feature chooses the return item then click the button before submitting. After that, the return locker door will open. On the same way, broken follows the same process but it also has a text box to type the broken detail after clicking the broken button on the broken item. Lost and extend date/time via the online website also has a similar process. It has to fetch the borrowed item from the database then choose the item and click the button. In the case of lost, broken or return items late, the user will get a penalty status and they have to ask the admin to change the penalty status back to a normal status.

Moreover, the evaluation of this system from the real users who take the student role, teacher role and admin role. The overall score of the system is 3.91 in the five full score from users that try the online website testing. The admin feedback result is 4.2 in the five full score.

5.3 Discussion

To summarize, the owner can manage storage utilizing CIEON Inventory Management System by allowing users to self-borrow and self-return items. The owner can also keep track of the item's status as well as the history of members and items. To make it more comfortable for users, the system allows them to reserve items online, declare lost things, and extend the return date via an internet website. Users will be able to borrow and reserve objects after the system has classified them. As a result, there will be no concerns with the user being unable to borrow or reserve products. Furthermore, the owner can identify broken items based on the item's principal broken detail from the user's comments. Users can also report lost items, or the admin can track a lost item back to the last person who borrowed it, which could result in a late return. The CIEON Inventory Management System compares the amount that the user informs the system with the date and time that the item was taken from the locker to detect the taken items. However, if a user takes the item for more than the amount specified, the alarm is triggered as the item passes through the exit door. Additionally, the lockers that employ this technology are always magnetically locked and can only be unlocked through the system's offline webpage. The locker door will open in response to a system command, allowing users to pick up the specified item only from within the locker in which it is stored. The locker doors have sensors to check if the door is opened for more than 30 seconds. If it is, the alarm will start. Furthermore, users who did not scan items with the RFID reader to change items status, the alarm will go off.

In addition, CIEON Inventory Management System helps to reduce the expense of the organization that orders new items to replace the lost items. The investment cost can be paid back in 1.36 months in the CIE laboratory. On the other hand, selling

outside will add a software solution fee of 180,000 Baht. Lastly, it will be worth it for the investors to invest in this system because it is scalable, and it solves the pain point.

5.3.1 Interesting problems

CIEON Inventory Management System necessitates a large number of hardware devices as there is a hardware issue. The main issue is that the hardware devices occasionally fail during testing. Initially, our team intended to use an auto detection system, but due to the cost and instability of the system, we are unable to proceed with the original plan. Furthermore, the issue happens while combining because CIEON Inventory Management System separates two main parts, and combining each part is quite difficult. Additionally, the database design is a challenge for this project. To be able to design suitable databases, it requires a lot of research and learning processes. The first ER diagram of this project has many tables. Therefore, the database should be redesigned to make it more efficient. In addition, the new database has been worked on this project. Apart from the software, the lock issues during working were solenoid locks overheating.

5.3.2 Proposed solution

The solution of the hardware issue is comparing each hardware and seeing the details of each hardware. After comparing all the hardware, it is then decided which hardware is most suitable. Therefore, downgrading the hardware part for example does not install all RFID inside the locker. Instead, we designed a system that uses less RFID but is able to detect all of the items that the user takes from the locker. Moreover, the old database, which has many tables is normalized. Hence, the evaluation of how to create a suitable database, as well as design one that has fewer tables, takes up less space, and can interact with all the system's functions is the proposed solution of database issue. Lastly, the solenoid locks were changed to magnetic locks to solve the overheating issue.

REFERENCE

- [1] “Employee Theft Statistics: Why Entrepreneurs Should Worry”, CreditDonkey, 2021. [Online]. Available: <https://www.creditdonkey.com/employee-theft-statistics.html>. [Accessed: 15- Dec- 2020].
- [2] Jwsuretybonds.com. [Online]. Available: <https://www.jwsuretybonds.com/blog/employee-theft-statistics>. [Accessed: 29-Jan-2021].
- [3] A. Zuckerman, “39 employee theft statistics: 2020/2021 impact & costs to business,” Comparecamp.com, 29-May-2020. [Online]. Available: <https://comparecamp.com/employee-theft-statistics/>. [Accessed: 04-Mar-2021].
- [4] D. Wilkie, “Why is workplace theft on the rise?,” SHRM, 04-Mar-2019. [Online]. Available: <https://www.shrm.org/resourcesandtools/hr-topics/employee-relations/pages/workplace-theft-on-the-rise-.aspx>. [Accessed: 24-Mar-2021].
- [5] M. Otto, J. Thornton, and Bootstrap contributors, “Bootstrap,” Getbootstrap.com. [Online]. Available: <https://getbootstrap.com/>. [Accessed: 26-Mar-2021].
- [6] M. Otto, J. Thornton, and Bootstrap contributors, “JavaScript · Bootstrap,” Getbootstrap.com. [Online]. Available: <https://getbootstrap.com/docs/3.4/javascript/>. [Accessed: 01-Apr-2021].
- [7] Hosting, “Web Hosting,” Hostneverdie.com. [Online]. Available: <https://www.hostneverdie.com/>. [Accessed: 19-Apr-2021].
- [8] “HTML for beginners the easy way: Start learning HTML & CSS today,” Html.com. [Online]. Available: <https://html.com/>. [Accessed: 02-Feb-2021].
- [9] “HTML Editors”, W3schools.com, 2021. [Online]. Available: https://www.w3schools.com/html/html_editors.asp. [Accessed: 19- Dec- 2020].
- [10] C. Eygi, “CSS for Beginners: What is CSS and How to Use it in Web Development?,” The Startup, 26-Apr-2019. [Online]. Available: <https://medium.com/swlh/css-for-beginners-what-is-css-and-how-to-use-it-in-web-development-5985afe53096>. [Accessed: 15-Dec-2020].
- [11] “CSS Tutorial,” W3schools.com. [Online]. Available: <https://www.w3schools.com/css/>. [Accessed: 14-Feb-2021].
- [12] “FileZilla - The free FTP solution,” Filezilla-project.org. [Online]. Available: <https://filezilla-project.org/>. [Accessed: 31-Mar-2021].
- [13] “Free bootstrap template 2021,” Mobirise.com. [Online]. Available: <https://mobirise.com/bootstrap-template/>. [Accessed: 27-Mar-2021].
- [14] “PHP MySQLi Functions,” W3schools.com. [Online]. Available: https://www.w3schools.com/php/php_ref_mysqli.asp. [Accessed: 17-Jan-2021].

- [15] phpMyAdmin contributors, “phpMyAdmin,” Phpmysqladmin.net. [Online]. Available: <https://www.phpmyadmin.net/>. [Accessed: 08-Feb-2021].
- [16] “PHP: MySQLi - Manual,” Php.net. [Online]. Available: <https://www.php.net/manual/en/book.mysqli.php>. [Accessed: 05-Jan-2021].
- [17] “JavaScript Tutorial,” W3schools.com. [Online]. Available: <https://www.w3schools.com/js/DEFAULT.asp>. [Accessed: 11-Feb-2021].
- [18] S. User, “Navicat Premium | Connects to multiple databases on a single GUI”, Navicat.com, 2021. [Online]. Available: <https://www.navicat.com/en/products/navicat-premium>. [Accessed: 02- Apr-2021].
- [19] “MySQL :: MySQL Workbench,” Mysql.com. [Online]. Available: <https://www.mysql.com/products/workbench/>. [Accessed: 28-Mar-2021].
- [20] “RFID: What are its Advantages and Disadvantages?,” Nuesmart.com, 30-Jun-2020. [Online]. Available: <https://www.nuesmart.com/rfid-what-are-its-advantages-and-disadvantages/>. [Accessed: 18-Nov-2021].
- [21] About the author Robert Triggs, “What is NFC and how does it work,” Androidauthority.com, 30-Jun-2019. [Online]. Available: <https://www.androidauthority.com/what-is-nfc-270730/>. [Accessed: 21-Mar-2021].
- [22] “How do Barcodes Work? Your Questions, Answered,” Lightspeedhq.com. [Online]. Available: <https://www.lightspeedhq.com/blog/how-do-barcodes-work>. [Accessed: 01-Jan-2021].
- [23] way2benefits, “Advantages and disadvantages of QR code - Way2Benefits,” Way2benefits.com, 15-Mar-2020. [Online]. Available: <http://way2benefits.com/advantages-and-disadvantages-of-qr-code/>. [Accessed: 21-Nov-2020].
- [24] Kaspersky, “QR Code Security: What are QR codes and are they safe to use?,” Kaspersky.com, 30-Mar-2021. [Online]. Available: <https://www.kaspersky.com/resource-center/definitions/what-is-a-qr-code-how-to-scan>. [Accessed: 01-Jun-2021].
- [25] “What are beacons, pros & cons and how much do they cost? The truth about beacons,” Bleesk.com. [Online]. Available: <https://bleesk.com/beacons.html>. [Accessed: 20-Nov-2020].
- [26] “Advantages of BLE (Bluetooth Low Energy),” Rfwireless-world.com. [Online]. Available: <https://www.rfwireless-world.com/Terminology/Advantages-and-Disadvantages-of-BLE-Bluetooth-Low-Energy.html>. [Accessed: 21-Dec-2020].
- [27] “Arduino - Introduction,” Arduino.cc. [Online]. Available: <https://www.arduino.cc/en/guide/introduction>. [Accessed: 01-Mar-2021].
- [28] R. Pi, “Teach, learn, and make with Raspberry PI,” Raspberrypi.org. [Online]. Available: <https://www.raspberrypi.org/>. [Accessed: 14-Apr-2021].

- [29] Maglocks, “What is a magnetic lock (maglock)?,” Maglocks.com. [Online]. Available: <https://www.maglocks.com/news/What-is-a-magnetic-Lock-maglock.html>. [Accessed: 12-Dec-2020].
- [30] “What is a buzzer? - quisure,” Quisure.com. [Online]. Available: <https://www.quisure.com/blog/faq/what-is-a-buzzer>. [Accessed: 02-Jan-2021].



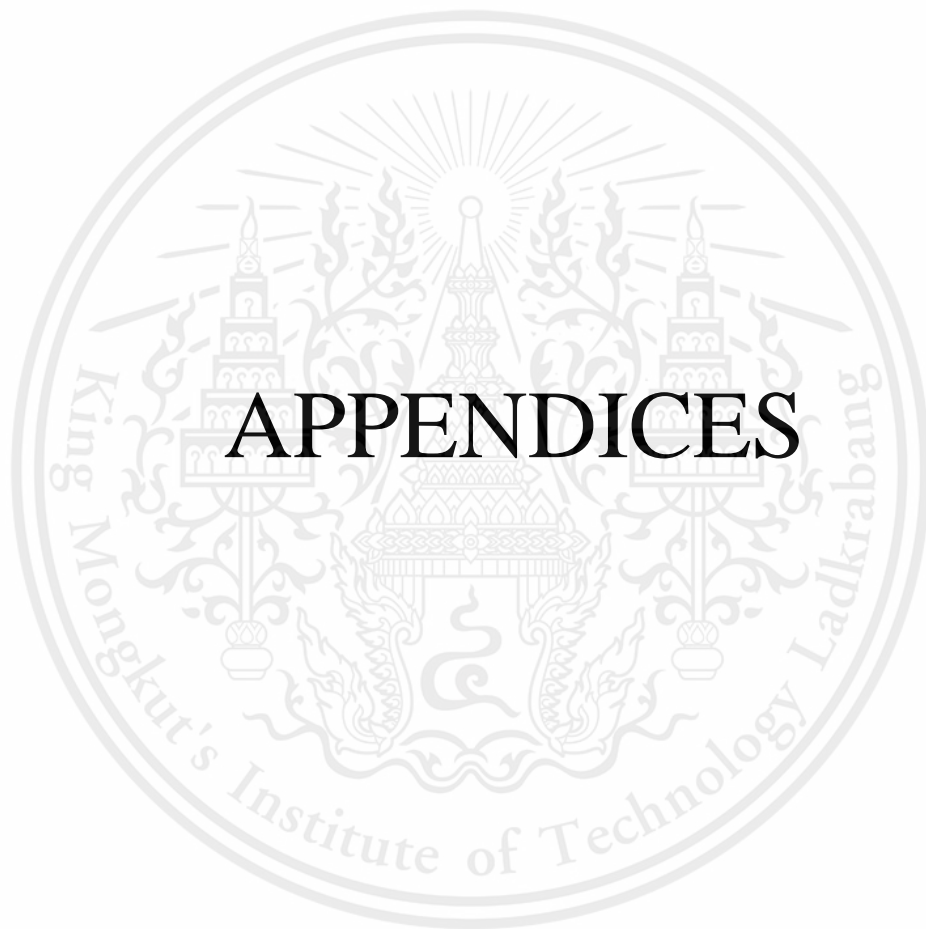

This material is reserved for educational use only, not allowed for commercial use.

APPENDIX A

The survey for using CIEON Inventory Management System for teachers, students and admins is used to gather the feedback of real users who tried this system. The description used in this survey is, “The lost items, operator not being able to track items or borrowers, and inventory management issues are the pain points to create this project. Objectives of this project are tracking users and items, helping stock management, and preventing lost items. This system target is a person who is related to CIE laboratory. This questionnaire is used for CIE capstone project (CIEON Inventory Management System) to get the results about user satisfaction.”.

The survey separates into three parts. The first part is about user profile, the second part is for every user to give feedback and other part is only for the admins.

Appendix Figure A.1 shows the user profile question in the first part of this survey testing. The survey has divided the users who tested the system into groups of students, teachers, and staff. Moreover, the students are divided into different years.

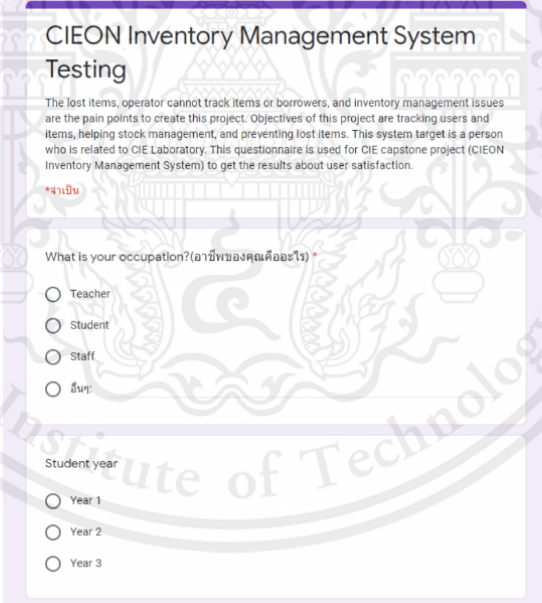

The image shows a screenshot of a web-based questionnaire titled "CIEON Inventory Management System Testing". The text on the page reads: "The lost items, operator cannot track items or borrowers, and inventory management issues are the pain points to create this project. Objectives of this project are tracking users and items, helping stock management, and preventing lost items. This system target is a person who is related to CIE Laboratory. This questionnaire is used for CIE capstone project (CIEON Inventory Management System) to get the results about user satisfaction." Below this text, there are two main sections of questions. The first section is titled "What is your occupation?(กรุณาเลือกคำตอบเดียว)" and has four radio button options: "Teacher", "Student", "Staff", and "อื่นๆ:". The second section is titled "Student year" and has three radio button options: "Year 1", "Year 2", and "Year 3". The entire form is overlaid on a large, faint watermark of King Mongkut's Institute of Technology Ladkrabang.

Appendix Figure A.1: Question about user profile

Appendix Figure A.2, A.3 and A.4 are the second part of this testing survey. Appendix Figure A.2 displays the user satisfaction question. Appendix Figure A.3 presents the system respond question when the users test the system. Appendix Figure A.4 represents the user’s opinion questions after the users have tested the system.

CIEON Inventory Management System Testing

*จำเป็น

Feedback

This feedback will be used in the evaluation of CIEON Inventory Management System Thesis.

1. The system is easy to use, convenient, and user-friendly each button has clear meaning and easily make user understand. For example, login button is use for login, forget password button use for reset user password. (ระบบใช้งานง่าย สะดวก เป็นมิตรกับผู้ใช้โดยแต่ละปุ่มมีความหมายที่ชัดเจนและทำให้สามารถเข้าใจได้โดยง่าย ยกตัวอย่างเช่น ปุ่ม login ใช้เพื่อการ login เข้าสู่ระบบ, ปุ่ม forget password ใช้เพื่อรีเซ็ต password ของผู้ใช้งาน) *

1 2 3 4 5
 Strongly disagree Strongly agree

2. Clarity of explanation of various components on the system screen. For example, if user type wrong email or password the system will show "login fail" message. (ความชัดเจนของคำอธิบาย ส่วนประกอบต่าง ๆ บนหน้าจอของระบบ ยกตัวอย่างเช่นถ้าผู้ใช้งานกรอกอีเมลหรือพาสเวิร์ดที่ระบบจะทำการแจ้งเตือนว่าคุณล็อกอินไม่สำเร็จ) *

1 2 3 4 5
 Strongly disagree Strongly agree

3. The system has a fast respond processing speed such as after user successfully reserve items system will immediately logout for user with a message "success". (ระบบมีการประมวลผลที่รวดเร็ว เช่น หลังจากที่มีผู้ใช้งานทำการจองเรียบร้อยแล้วระบบจะทำการล๊อคเอาท์ทันทีและแจ้งเตือนว่า จองสำเร็จ) *

1 2 3 4 5
 Strongly disagree Strongly agree

4. The system provides accurate notifications when wrong information is entered such as in login page if user type in email with out @ sign system will show message "Email need @ sign". (ระบบมีการแจ้งเตือนที่ถูกต้องเมื่อมีการกรอกข้อมูลผิดพลาด ยกตัวอย่างเช่นหน้า login ถ้าผู้ใช้งานไม่ใส่@ ในช่องของemailระบบจะทำการแจ้งเตือนให้ผู้ใช้งานใส่ @ ลงไป(email)) *

1 2 3 4 5
 Strongly disagree Strongly agree

5. The system will display results that are accurate and meet the needs of users. For example, If user reserve items after finish process user should receive email with same exact information (ระบบมีการแสดงผลรายงานที่ถูกต้องและตรงกับความต้องการของผู้ใช้ ยกตัวอย่างเช่นหลังจากที่มีงานได้ดำเนินการจองอุปกรณ์ หลังจากเสร็จสิ้นกระบวนการผู้ใช้งานจะได้รับemailแจ้งเตือนเกี่ยวกับของตามที่ผู้ใช้งานได้ทำการจองไป) *

1 2 3 4 5
 Strongly disagree Strongly agree

Appendix Figure A.2: Questions about user satisfaction

Appendix Figure A.3: Questions about system respond

This material is reserved for educational use only, not allowed for commercial use.

6. This system can help user reduce process for borrow and return items compare with present process which don't have this system. (ระบบนี้สามารถช่วยลดขั้นตอนในการจัดการการยืมและคืนของอุปกรณ์ที่มียังงบบนที่ในปัจจุบันนี้) *

1 2 3 4 5

Strongly disagree Strongly agree

7. You agree to the use of this system. (คุณเห็นด้วยกับการใช้ระบบนี้) *

1 2 3 4 5

Strongly disagree Strongly agree

8. According to no. 7, after using this system, would you agree to recommend this system to others? (จากข้อ 8 ถ้าใช้ระบบนี้แล้ว คุณเห็นด้วยที่จะแนะนำระบบนี้ให้คนอื่นใช่) *

1 2 3 4 5

Strongly disagree Strongly agree

Comment

หมายเหตุเพิ่มเติม

Appendix Figure A.4: Questions about user opinion

Appendix Figure A.5 and Appendix Figure A.6 are the last part of this survey testing. Appendix Figure A.5 shows the admin satisfaction questions. Appendix Figure A.6 presents the system response of the admin part in the system.

CIEON Inventory Management System Testing

Administrator Only

This administrator feedback will be used in the evaluation of CIEON Inventory Management System Thesis.

1. Easy to use data management system. For example, the system has buttons or icons that easily to stand such as add data (ระบบในการจัดการข้อมูลไม่ยุ่งยาก ตัวอย่างเช่นระบบที่มีปุ่มหรือสัญลักษณ์ที่เข้าใจง่ายเช่นสัญลักษณ์สีขาวที่ใช้ในการเพิ่มข้อมูล)

1 2 3 4 5

Strongly disagree Strongly agree

2. Able to handle information accurately in adding data, editing data, viewing data and deleting data. For example, after adding data, the new data can be view on viewing data page. (สามารถจัดการข้อมูลได้อย่างถูกต้องในการเพิ่มข้อมูล ลบข้อมูล แก้ไขข้อมูลและลบข้อมูล ตัวอย่างเช่นเมื่อทำการเพิ่มข้อมูลใหม่แล้วผู้ใช้สามารถดูข้อมูลที่ถูกต้องในหน้าข้อมูลได้)

1 2 3 4 5

Strongly disagree Strongly agree

Appendix Figure A.5: Questions about admin satisfaction

This material is reserved for educational use only, not allowed for commercial use.

3. Able to track individual and item information accurately. (สามารถติดตามข้อมูลเฉพาะบุคคลได้อย่างถูกต้อง)

1 2 3 4 5

Strongly disagree Strongly agree

4. The system can make the management of the goods more convenient. (ระบบสามารถช่วยให้การบริหารจัดการของใน CIE ทำได้สะดวกมากขึ้น)

1 2 3 4 5

Strongly disagree Strongly agree

5. System can help administer track lost and broken items more conveniently. (ระบบสามารถช่วยผู้ดูแลระบบติดตามของหายและพังได้สะดวกมากขึ้น)

1 2 3 4 5

Strongly disagree Strongly agree

Admin comment

คำตอบของคุณ

Appendix Figure A.6: Question about system response

APPENDIX B

The admin manual explains the process of admin feature step by step with the picture supporting.

User Manual: Admin

- **Homepage**

1. According to Appendix Figure B.1, the admin can view the red alert messages that notifies the admin which items are almost out of stock.
2. The description feature describes the admin's duties and the animation video to demonstrate how to use all admin's features.
3. On the left of the page, there is a menu bar. When the admin clicks the menu bar that has the down arrow icon, those menus will drop down to let the admin see the features inside which are add data and view data features.
4. The menu bar on the left page has the logout button.

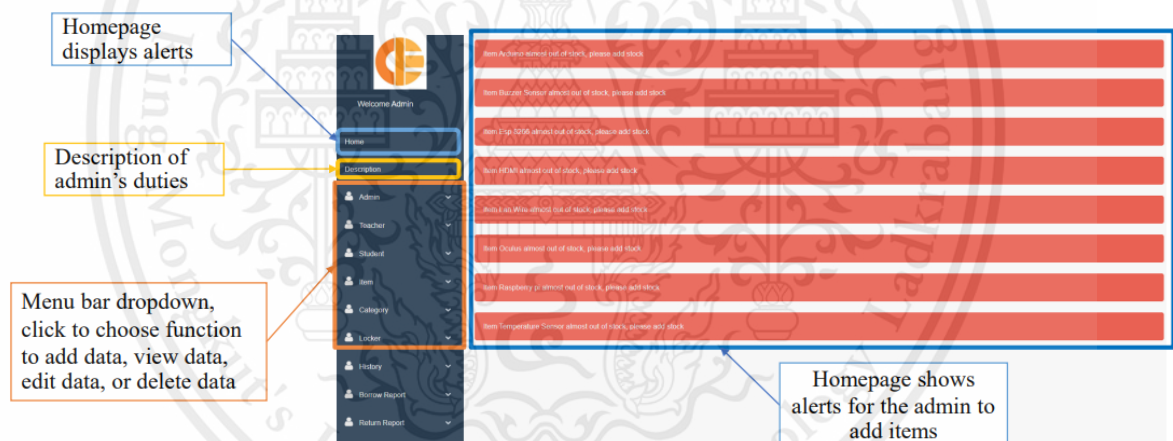

Appendix Figure B.1: The admin homepage

- **Adding data features**

1. The admin has to choose the add data feature.
2. Appendix Figure B.2 presents the example of the add data page.
3. The admin fills in all the required data in the box and uploads the picture.
4. After typing all the data and uploading the picture, the admin has to click the save button to save the data, then the system will direct the admin to the view data page to view the updated data.
5. The admin chooses the cancel button to cancel the add feature. Therefore, the system will take the admin to the view data page to view the current data.

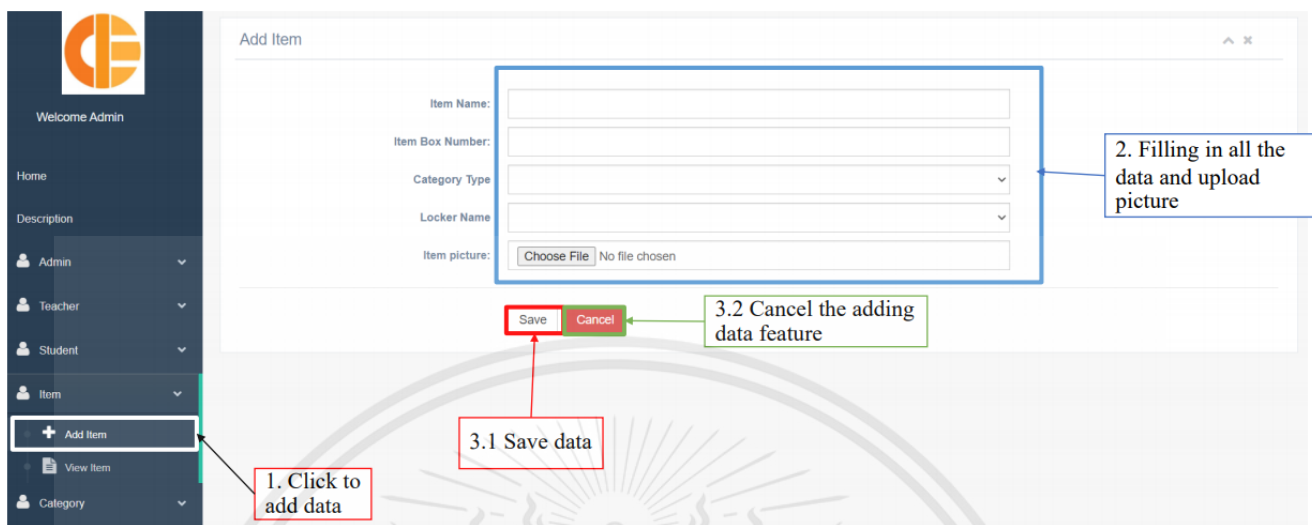

Appendix Figure B.2: Example of the add data page

- **Adding item features**

1. The admin has to choose the item and click the dropdown feature as shown in Appendix Figure B.2.
2. Select add item and the system will direct the admin to the add item page.
3. The admin has to fill in all the required data in the box and upload the picture.
4. The admin chooses the cancel button to cancel the add feature. The system will then take the admin to the view data page to view the current data.
5. However, after typing all the data and uploading the picture, the admin has to click the save button to save the data, then the system will direct the admin to the view item page to view the updated item.
6. The updated item data of the RFID tag number will be zero as shown in Appendix Figure B.3.
7. The admin has to scan the RFID tag with the RFID reader to update the RFID tag number.
8. After scanning the tag with the RFID reader, the admin has to refresh the view item page, then the admin will see the updated RFID tag number.

Esp 8266	6	12827396		Board	1	Available	2021-05-24 12:50:26		
HDMI	5	11399679		Wire	2	Available	2021-05-24 12:49:44		
HDMI	12	1006157		Wire	2	Available	2021-05-24 12:49:44		
Lan Wire	9	12638260		Wire	2	Available	2021-05-24 12:53:08		
Oculus	4	1773988		VR	3	Available	2021-05-24 12:49:26		
Oculus	11	14411940		VR	3	Available	2021-05-24 12:49:26		
Oculus	24	0		VR	3	Available	2021-06-07 22:13:40		

Showing 1 to 10 of 13 entries

Previous 1 2 Next

Appendix Figure B.3: The view item page after adding items without scanning the RFID tag

Esp 8266	6	12827396		Board	1	Available	2021-05-24 12:50:26		
HDMI	5	11399679		Wire	2	Available	2021-05-24 12:49:44		
HDMI	12	1006157		Wire	2	Available	2021-05-24 12:49:44		
Lan Wire	9	12638260		Wire	2	Available	2021-05-24 12:53:08		
Oculus	4	1773988		VR	3	Available	2021-05-24 12:49:26		
Oculus	11	14411940		VR	3	Available	2021-05-24 12:49:26		
Oculus	24	12367569		VR	1	Available	2021-06-07 22:13:40		

Showing 1 to 10 of 13 entries

Previous 1 2 Next

Appendix Figure B.4: The view item page after scanning the RFID tag

- **View data features:**

1. The admin has to choose the view data feature.
2. Appendix Figure B.5 displays the example of the view data page.
3. The admin can use a search box to find the data.
4. According to Appendix Figure B.6, the admin can click the number page at the bottom of the table to see other data.

5. If the admin clicks the CSV button, the system will download an excel file that contains all the data in the view page.
6. If the admin clicks the copy button, the system will copy all the data in the view page.
7. If the admin clicks the print button, the system will print all the data in the view page.
8. In the view page, there is an edit icon that is used to edit data and the bin icon, which is used to delete data.
9. The menu bar on the left page has the logout button.

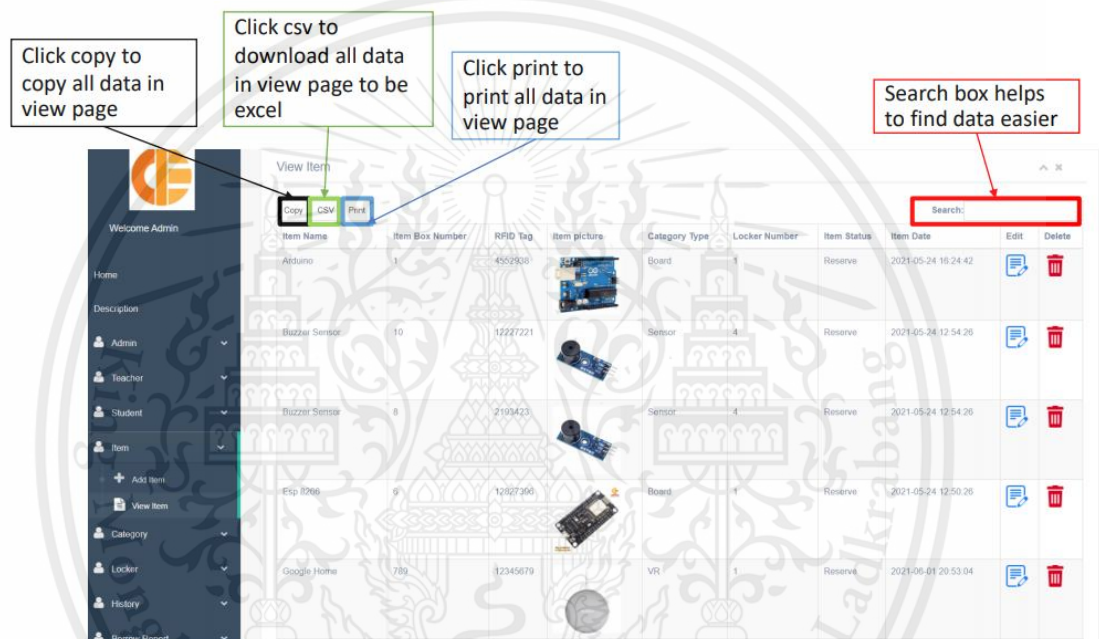

Appendix Figure B.5: Example of the view data page on the top of the page

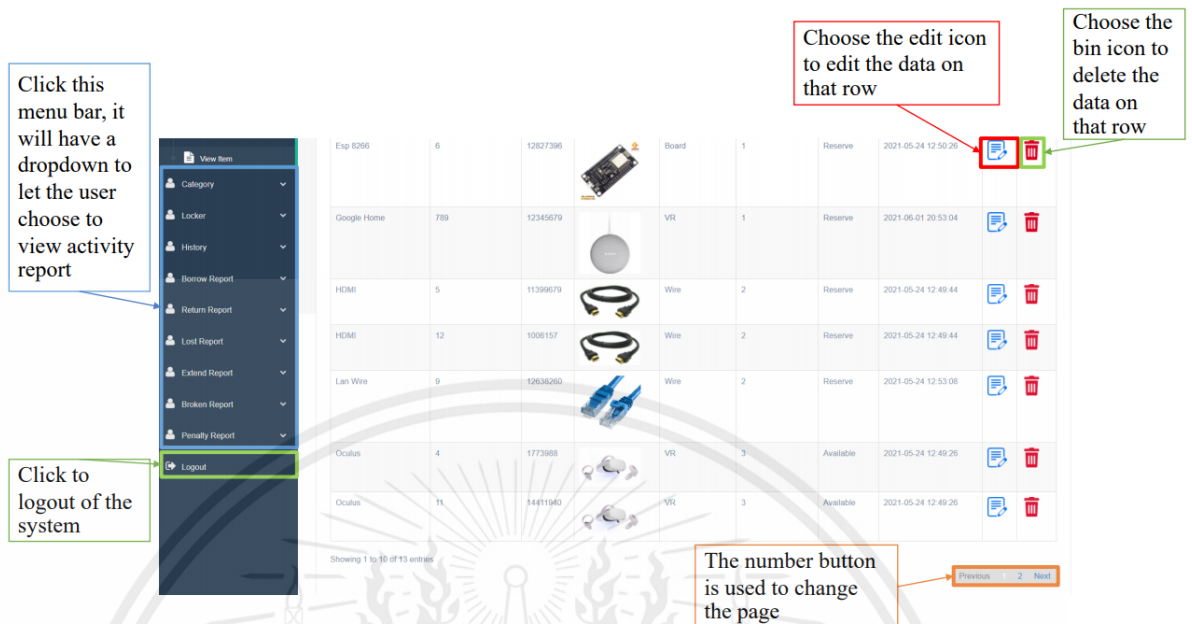

Appendix Figure B.6: Example of the view data page on the bottom of the page

- **View activity features:**

1. The admin has to choose the view data feature.
2. Appendix Figure B.7 displays the view activity page.
3. The admin can use the search box to find the data.
4. The admin can view activity of users and items.
5. The admin can delete the activity by clicking the bin icon.
6. The admin can delete the history by clicking clear history to delete history.
7. Appendix Figure B.8 shows the clear history page. The process begins with selecting the first date to delete activity history, then click the submit button.

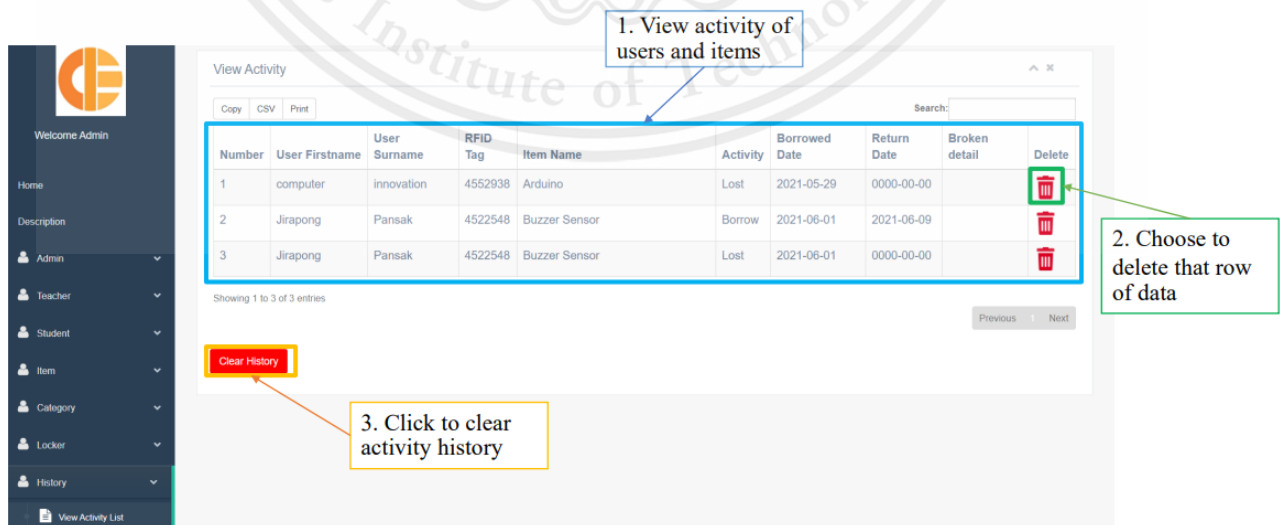

Appendix Figure B.7: The view activity page of the history feature

This material is reserved for educational use only, not allowed for commercial use.

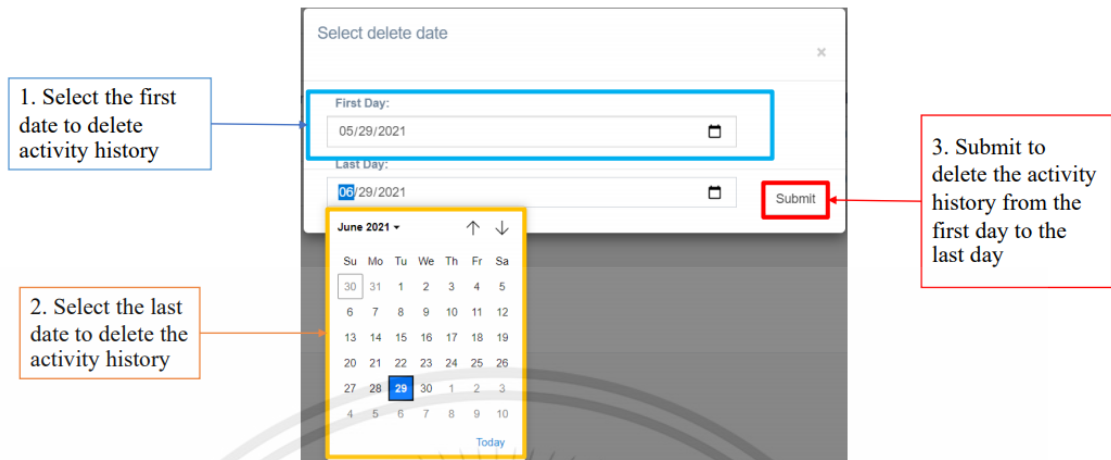

Appendix Figure B.8: The clear history page

- **View report features**

1. The admin has to choose the view report feature.
2. Appendix Figure B.9 shows the example of the view report page.
3. The admin can use the search box to find the data.
4. The admin can click the number page at the bottom of the table to see the other data.
5. If the admin clicks the CSV button, the system will download excel file that contains all the data in the view page.
6. If the admin clicks the copy button, the system will copy all the data in the view report page.
7. If the admin clicks the print button, the system will print all the data in the view report page.
8. In the view report page, it has the edit icon that is used to edit data and the bin icon, which is used to delete data.
9. The menu bar on the left page has the logout button.

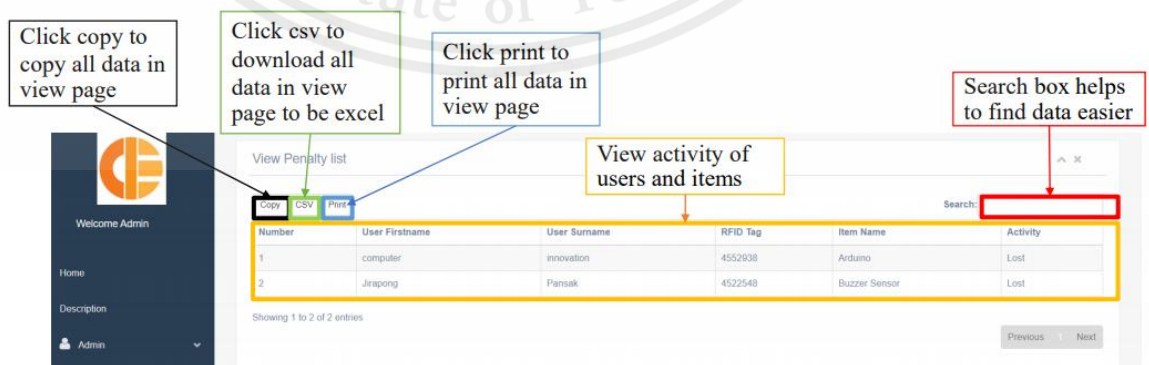

Appendix Figure B.9: Example of the view report page

- **Delete data features**

1. The admin has to choose the view data feature.
2. Appendix Figure B.10 displays the example of the delete data page.
3. The admin can use the search box to find the data.
4. The admin can delete the activity by clicking the bin icon at the same row of that item.
5. The system will pop up the message, “Do you want to delete?”.
6. If the admin clicks OK, the system will delete that data. If the admin selects the cancel button, then the system will cancel the delete function and direct the admin back to the view page.

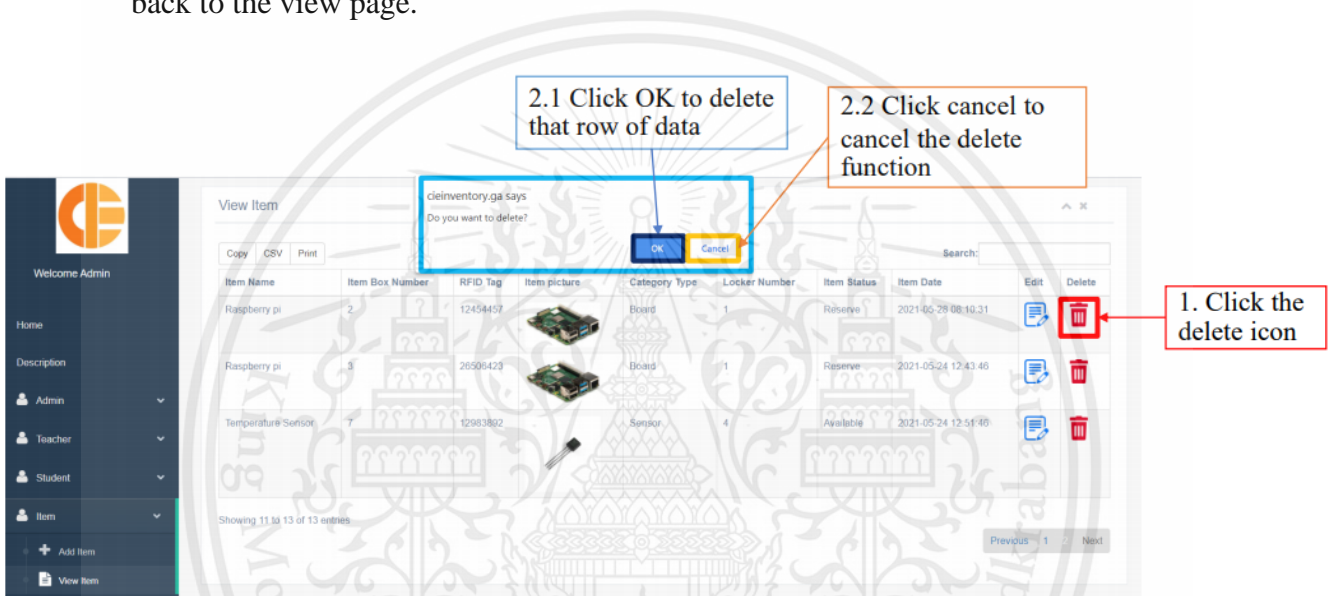

Appendix Figure B.10: Example of the delete data page

- **Edit data features:**

1. The admin has to choose the view data feature.
2. Appendix Figure B.11 displays the example of the edit data page.
3. The admin can use the search box to find the data.
4. The admin can edit the data by clicking the edit icon at the same row of that item.
5. The system will pop up the message, “Do you want to edit?”.
6. If the admin clicks OK, the system will edit that data. If the admin selects the cancel button, then the system will cancel the edit function and direct the admin back to the view page.
7. Appendix Figure B.12 displays edit the data page. The admin can edit data by typing new data or choosing the dropdown to change the user.
8. After the admin edits the data, click the save button to save the edit data. The system will then show the message “Successfully edited the information” as shown in Appendix Figure B.13.
9. But if the admin clicks the cancel button, the system will cancel the edit function and direct the admin back to the view page.

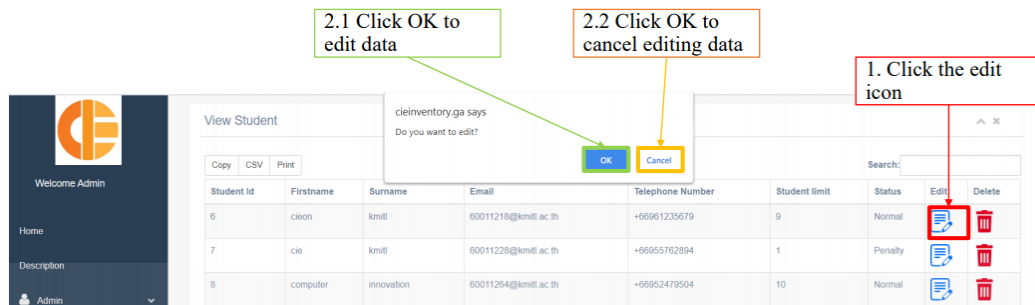

Appendix Figure B.11: Example of the view data page

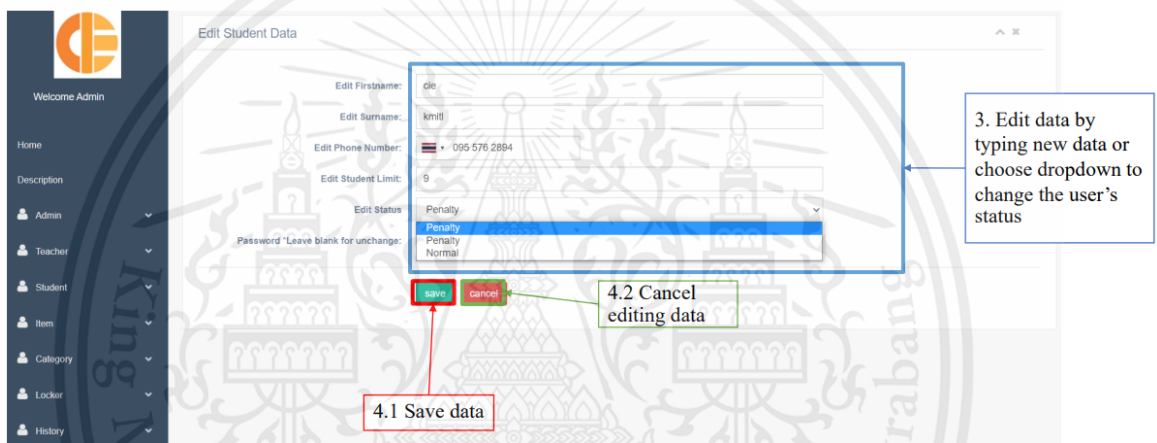

Appendix Figure B.12: The editing page of student



Appendix Figure B.13: The system declares the message “Successfully edited the information”