

Effects of TiO₂ coating on adhesion properties and mechanical properties of polyethylene composite reinforced with fiberglass fabric/epoxy resin



**A Report Submitted in Partial Fulfillment of the Requirement
for the Degree of Bachelor of Engineering (Petrochemical Engineering)
Department of chemical Engineering, Faculty of Engineering,
King Mongkut's Institute of Technology Ladkrabang
Academic Year 2018**

ผลของไทเทเนียมไดออกไซด์ต่อคุณสมบัติความชอบน้ำและคุณสมบัติเชิงกล
ของวัสดุคอมโพสิตที่เสริมแรงด้วยเส้นใยไฟเบอร์กลาสและอีพอกซีเรซิน



ปริญญานิพนธ์นี้เป็นส่วนหนึ่งของการศึกษาตามหลักสูตร
วิศวกรรมศาสตรบัณฑิต สาขาวิชาวิศวกรรมปิโตรเคมี
ภาควิชาวิศวกรรมเคมี คณะวิศวกรรมศาสตร์
สถาบันเทคโนโลยีพระจอมเกล้าเจ้าคุณทหารลาดกระบัง
ปีการศึกษา 2561

Title Effects of TiO₂ coating on adhesion properties and mechanical properties of polyethylene composite reinforced with fiberglass fabric/epoxy resin

By Mr. Tanakorn Patcharapisutsin

Field of Study Petrochemical Engineering

Advisor Asst. Prof. Dr. Kunlanan Kiatkittipong and
Asst. Prof. Dr. Wipoo Sriseubsai

Accepted by the Faculty of Engineering, King Mongkut's Institute of Technology Ladkrabang in Partial Fulfillment of the Requirements for the Degree of Bachelor of Engineering (Petrochemical Engineering).

Thesis Committee



Kunlanan

(Asst. Prof. Dr. Kunlanan Kiatkittipong)

Chairman

Tanawan Pinnarat.

(Asst. Prof. Dr. Tanawan Pinnarat)

Committee

Kriangsak Kraiwattanawong

(Asst. Prof. Dr. Kriangsak Kraiwattanawong)

Committee

Title	Effects of TiO ₂ coating on adhesion properties and mechanical properties of polyethylene composite reinforced with fiberglass fabric/epoxy resin
By	Mr. Tanakorn Patcharapisutsin
Field of Study	Petrochemical Engineering
Advisor	Asst. Prof. Dr. Kunlanan Kiatkittipong and Asst. Prof. Dr. Wipoo Sriseubsai

Abstract

The objective of this research is to study the amount of titanium dioxide that affects to adhesion properties and the mechanical properties of composite materials reinforced with fiberglass and epoxy resin. At the present, high-speed train technology has been used and study. From the study, it was found that the weight of the train affects the speed of the train. Therefore, composite materials are one of the options that are used in production of train's body because of their light weight and high strength. In addition, titanium dioxide (TiO₂) is added to the composite material to increase the self-cleaning ability. In this study, the experiment starts by making composite materials that are reinforced with fiberglass fibers and epoxy resin and vary the amount of titanium dioxide that is 0, 1, 2, 3, 4, and 5 percent by weight (of epoxies). To study the adhesion properties and mechanical properties of the material, Contact angle measurement, Tensile Testing Machine, and Izod Impact Testing Machine are measured. The result from the experiment shows that an increase of the amount of titanium dioxide increased the contact angle from the contact angle measurement. It means that the material has the hydrophobic property. When the material is tested with the Tensile Testing Machine, it was found that an increase of titanium dioxide can increase the strength of the material, but the elasticity of the material decreases due to the formation of chain entanglement in matrix system. For the Izod Impact tests, when amount of titanium dioxide increases, the impact strength of the material decreases.

Keywords: Titanium dioxide, High-speed train, Adhesion properties, Composite

เรื่อง	ผลของไทเทเนียมไดออกไซด์ต่อคุณสมบัติความชอบน้ำและคุณสมบัติเชิงกลของวัสดุคอมโพสิตที่เสริมแรงด้วยเส้นใยไฟเบอร์กลาสและอีพอกซีเรซิน
โดย	นายธนากร พ็ชรพิสุทธิ์สิน
อาจารย์ที่ปรึกษา	ผศ.ดร.กุลนันท์ เกียรติกิตติพงษ์, ผศ.ดร.วิญ ศรีสืบสาย
สาขาวิชา	วิศวกรรมปิโตรเคมี

บทคัดย่อ

งานวิจัยนี้มีวัตถุประสงค์เพื่อศึกษาปริมาณของไทเทเนียมไดออกไซด์ที่มีผลต่อคุณสมบัติการชอบน้ำและคุณสมบัติเชิงกลของวัสดุคอมโพสิตที่เสริมแรงด้วยเส้นใยไฟเบอร์กลาสและอีพอกซีเรซิน เนื่องจากในปัจจุบันได้มีการนำเทคโนโลยีรถไฟฟ้าความเร็วสูงเข้ามาใช้ ซึ่งจากการศึกษาพบว่าน้ำหนักของรถไฟฟ้ามีผลต่อความเร็วของรถไฟฟ้า ดังนั้นวัสดุคอมโพสิตจึงเป็นหนึ่งในตัวเลือกที่ถูกนำมาใช้ในการผลิต เนื่องจากมีน้ำหนักที่เบาและมีความแข็งแรงสูง นอกจากนี้ ไทเทเนียมไดออกไซด์ (TiO_2) ถูกเพิ่มเข้าไปในวัสดุคอมโพสิตเพื่อเพิ่มความสามารถในการทำความสะอาดตัวเอง ทั้งนี้ ทางผู้จัดทำจึงได้ทำการทดลองโดยทำวัสดุคอมโพสิตที่เสริมแรงด้วยเส้นใยไฟเบอร์กลาสและอีพอกซีเรซินที่มีปริมาณไทเทเนียมไดออกไซด์ต่างกัน นั่นคือ ร้อยละ 0, 1, 2, 3, 4, และ 5 โดยน้ำหนักเมื่อเทียบกับน้ำหนักของอีพอกซีเรซิน เพื่อศึกษาคุณสมบัติการชอบน้ำและคุณสมบัติการดัดงอของวัสดุด้วยเครื่องทดสอบ Contact angle measurement, Tensile Testing Machine, และ Izod Impact Testing Machine ซึ่งจากการทดลอง พบว่า เมื่อปริมาณของไทเทเนียมไดออกไซด์เพิ่มขึ้นคุณสมบัติจากเครื่อง Contact angle measurement ก็จะเพิ่มขึ้นด้วยเช่นกัน นั่นแสดงให้เห็นถึง สภาวะการไม่ชอบน้ำ (hydrophobic property) ของวัสดุ และเมื่อทดสอบด้วยเครื่อง Tensile Testing Machine พบว่าเมื่อปริมาณของไทเทเนียมไดออกไซด์เพิ่มมากขึ้นความแข็งแรงของวัสดุจะเพิ่มขึ้นด้วยเช่นกัน แต่ความยืดหยุ่นของวัสดุ นั้นจะมีค่าลดลง เนื่องจากการก่อตัวของโซ่แบบพันกันไปมาในระบบ เช่นเดียวกับผลที่ได้จากการทดสอบความทนทานต่อแรงกระแทก เมื่อปริมาณของไทเทเนียมเพิ่มขึ้น ค่าความทนทานต่อแรงกระแทกของวัสดุจะมีค่าลดลงด้วยเช่นกัน

คำสำคัญ: ไทเทเนียมไดออกไซด์, รถไฟฟ้าความเร็วสูง, คุณสมบัติการชอบน้ำ, คอมโพสิต

Acknowledgements

I would like to express the deepest appreciation to my advisor Asst. Prof. Dr. Kunlanan Kiatkittipong and Asst. Prof. Dr. Wipoo Sriseubsai, who have the attitude and the substance of a genius: they continually and convincingly conveyed a spirit of adventure in regard to research and scholarship, and an excitement in regard to teaching. Without their guidance persistent help, this dissertation would not have been possible.

I would like to thank my committee member, Asst. Prof. Dr. Tanawan Pinnarat Asst. Prof. Dr. Kriangsak Kraiwattanawong, for the suggestions related to my research without their suggestion, my research might be not developed.

I would like to thank department of chemical engineering, King Mongkut's Institute of Technology Ladkrabang and authorities, Mr. Pisan Ponpo, Miss Pimchai Poochanakit, and Mr. Aekkarat Bumrunghaichaichan, that support the equipment and workspace. My research might be not successful without them.

Finally, I would like to thank teachers for the knowledge that have been teaching in the bachelor degree of Petrochemical Engineering.

Tanakorn Patcharapisutsin

Table of Contents

	Page
Abstract	I
Acknowledgements	II
Table of Contents	III
List of Figures	V
List of Tables	VI
CHAPTER I: INTRODUCTION	
1.1 Background	1
1.2 Objectives	2
1.3 Scopes of work	2
1.4 Expected Outputs	2
CHAPTER II: THEORY AND LITERATURE REVIEW	
2.1 Theory	
2.1.1 Titanium dioxide (TiO ₂)	3
2.1.2 Epoxy resin	4
2.1.3 Fiberglass	5
2.1.4 Composite materials	5
2.1.5 Adhesion properties	6
2.1.6 Tensile testing analysis	7
2.1.7 Izod impact analysis	9
2.2 Literature Review	11
CHAPTER III: RESEARCH METHODOLOGY	
3.1 Composites preparation	12
3.1.1 Chemical and Material	12
3.1.2 Equipment and Apparatus	12
3.1.3 Procedures	13
1) Preparation of Epoxy resin with Titanium dioxide	13
2) Composites coating	13
3) Comparison of the amount of titanium dioxide particles	13
3.2 Study of composites properties	14

Table of Contents (Cont.)

	Page
3.1.1 Adhesion properties	14
3.1.2 Tensile properties	14
3.1.3 Izod impact properties	14
CHAPTER IV: RESULTS AND DISCUSSIONS	15
Contact Angle Measurement	16
Tensile Testing Machine	17
Izod Impact Testing Machine	20
CHAPTER V: CONCLUSIONS	23
5.1 CONCLUSIONS	23
5.2 SUGGESTIONS	23
REFERENCES	24
APPENDIX	25

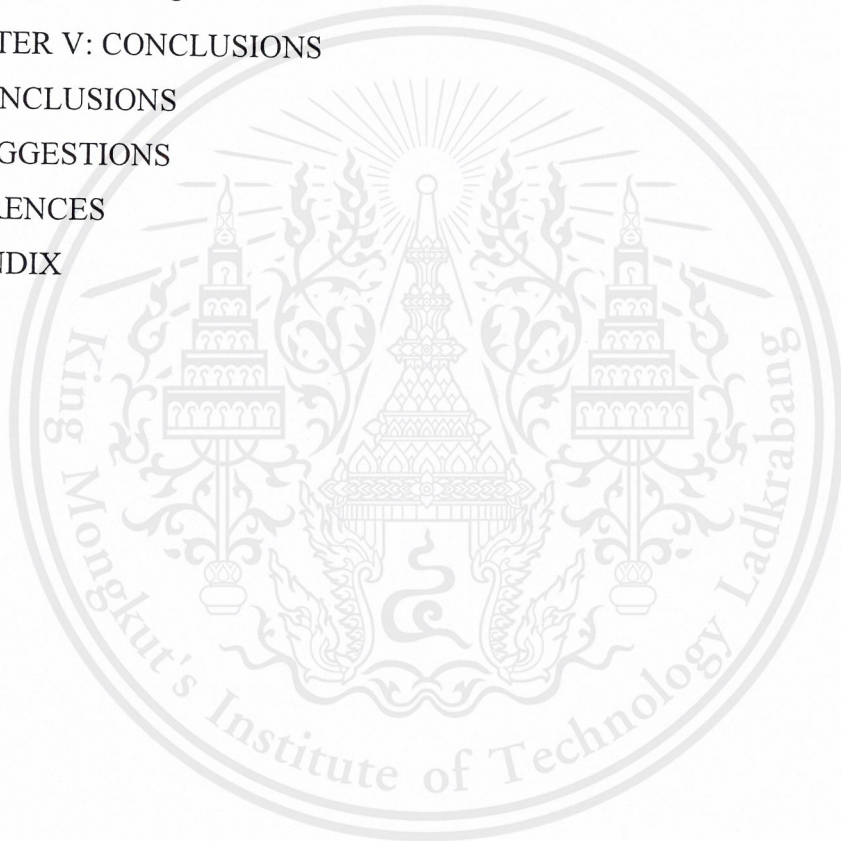

List of Figures

	Page
Figure 2.1: Structure of titanium dioxides	3
Figure 2.2: Photodegradation of titanium dioxides	3
Figure 2.3: Hydrophilic properties. of titanium dioxides	4
Figure 2.4: Structure of epoxies	4
Figure 2.5: Relationship between adhesion and cohesion	6
Figure 2.6: Relationship between hydrophilic surface/ hydrophobic surface with contact angle.	7
Figure 2.7: Example of the samples in dumbbell shape	7
Figure 2.8: Example of the graph between stress and strain	9
Figure 2.9: Dimensions of Izod-Type Test Specimen	10
Figure 4.1: Specimens for adhesion properties and mechanical properties testing	15
Figure 4.2: Contact angle between surface and water	17
Figure 4.3: Relationship between stress and strain	18
Figure 4.4. Relationship between the amount of titanium dioxide and Yield point	20
Figure 4.5: Relationship between the amount of titanium dioxide and Elastic	20
Figure 4.6: Relationship between the amount of titanium dioxide and Izod Impact Value	21
Figure 4.7: Relationship between the amount of titanium dioxide and Elastic & Yield Point & Izod Impact Energy	22

List of Tables

	Page
Table 2.1: ASTM D638 Specimen Dimensions	8
Table 2.2: ASTM D256 Specimen Dimensions	10
Table 4.1: Contact Angle test conditions	16
Table 4.2: Contact Angle between surface and water.	16
Table 4.3: Tensile Testing Machine Conditions	17
Table 4.4: Data processing items	19
Table 4.5: Izod Impact Testing Machine Conditions	20
Table 4.6: Izod Impact Testing data	21



INTRODUCTION

1.1 Background

Nowadays, transportation are necessary to drive the development of economic. This transportation is not only the freight but also includes the traveling of people. An effective transportation is the main factor to improve the level of economic development of the country to the international, including new opportunities for trade and tourism. There are many ways to transport in Thailand. One of the most widely used is rail transport or transportation by trains.

From the previous reason, rail's transportation has been improved to get more efficiency. The innovations that has been attracted attention is the production of high-speed train. In recent years, high-speed train has been studied and developed in the part of rail systems, power and energy systems, the material that used to produce this train, and others. For material part, it was found that an decrease of weight is significant to increase train's speed ability. Therefore, the composites are one of choices that many studies pay more attention to use in train's body production because the composites is lightweight and strong material.

Moreover, titanium dioxide (TiO_2) is added into the composite to increase its self-cleaning ability. One of the properties of titanium dioxide is the chemical catalytic activity of the surface of titanium dioxide particles especially in the anatase type when it's under the sun or ultraviolet. Titanium dioxide particles helps to eliminate emission from car exhaust and degradation of the dirt on the surface of the material. Moreover, the surface of material coated with titanium dioxide has good adhesion properties. When it rains, rainwater it spread over the material and removes the dirt that has already been degraded.

In this work, adhesion properties between surface with titanium dioxide and water and mechanical properties of materials were study. Composite materials were prepared by polyethylene plastic swathed with fiberglass fabric, epoxy is a bonding agent for fiberglass fabric to remain at the surface of the plastic. In the epoxy used, there were added titanium dioxide particles in different amount of its to compare the adhesion properties by the contact angle measurement. However, mechanical properties of materials are required to study for further usage. Tensile Testing Machine and Izod Impact Testing Machine were used to analysis this properties.

This material is reserved for educational use only, not allowed for commercial use.

Forbidden to modify the content, and cite the document when use

1.2 Objectives

To get the optimum point of the amount of titanium dioxide added into the specimen in both ways of adhesion properties and mechanical properties.

1.3 Scopes of Work

- 1.3.1 The amount of titanium dioxide are used to study is 0%wt. to 5%wt..
- 1.3.2 Study adhesion properties by contact angle analysis.
- 1.3.3 Study mechanical properties by tensile testing analysis and impact testing analysis.

1.4 Expect outputs

- 1.4.1 Composite that coated with fiberglass fabric in epoxy with titanium dioxide.
- 1.4.2 The trend between titanium dioxide particles and adhesion properties.
- 1.4.3 The trend between titanium dioxide particles and mechanical properties.

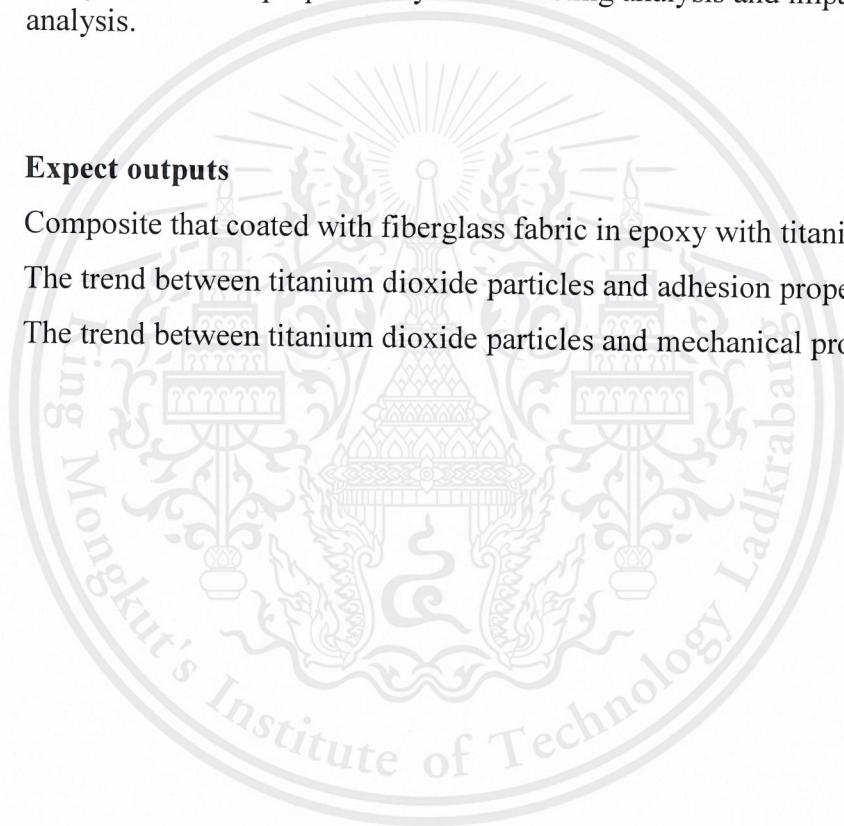

CHAPTER II

LITERATURE REVIEW

2.1 Theory

2.1.1 Titanium dioxide (TiO₂)

Titanium is the most common element that found in the Earth's crust, plants, and animals. It is naturally interacts with oxygen to form titanium oxides that found in ores, indigenous dusts, sands and soils.

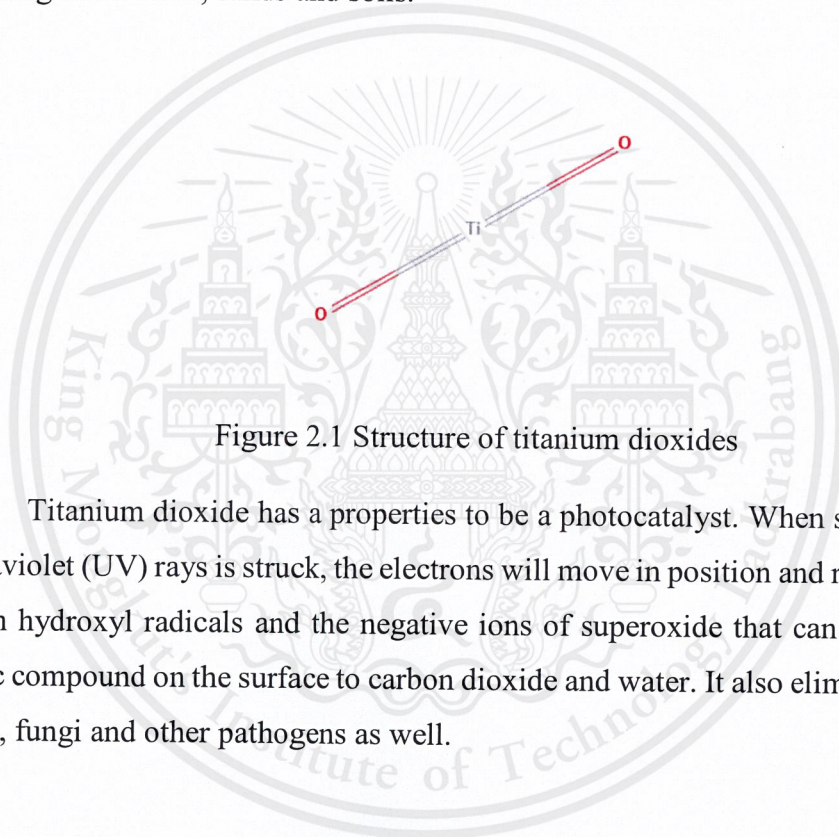

Titanium dioxide has a properties to be a photocatalyst. When sunlight particle or ultraviolet (UV) rays is struck, the electrons will move in position and react chemically to form hydroxyl radicals and the negative ions of superoxide that can degradable the organic compound on the surface to carbon dioxide and water. It also eliminates bacteria, viruses, fungi and other pathogens as well.

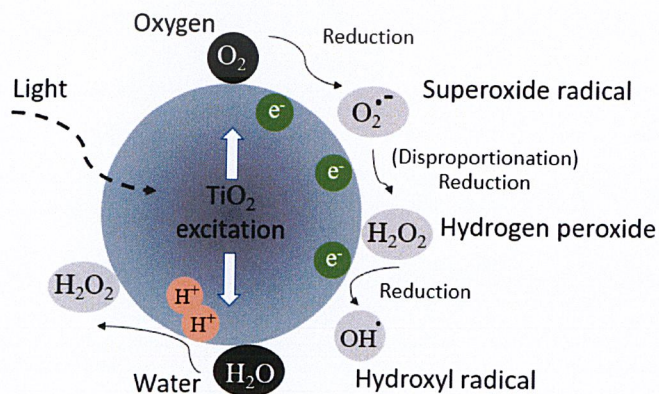

Figure 2.2 Photodegradation of titanium dioxides

This material is reserved for educational use only, not allowed for commercial use.

Forbidden to modify the content, and cite the document when use

Titanium dioxide also has a hydrophilic properties. Under the UV irradiation, the oxygen ions in the air are adsorbed and become chemically adsorbed water (surface hydroxyl groups), so the surface of the TiO_2 will present the hydrophilic characteristics. When the UV irradiation is stopped, the chemical adsorption of hydroxyl will stop and replaced by the oxygen in the air, then returns to the hydrophobic state. Organic matter adsorbed on the surface will turns to the hydrophobic state too. After that, water droplets on the surface will replace the organic matter that adsorbed at the surface and wash away organic dirt. This reaction is a self-cleaning mechanism

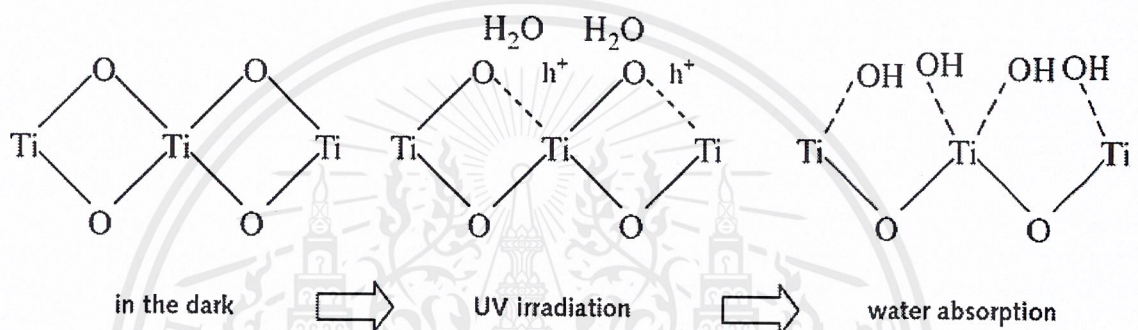

Figure 2.3 Hydrophilic properties of titanium dioxides

2.1.2 Epoxy resin

Epoxy resins, also known as polyepoxides, are polymers that contain epoxide groups. There are low molecular weight pre-polymers or higher molecular weight polymers which normally contain at least two epoxide groups. The epoxide group is also referred to as a glycidyl or oxirane group.

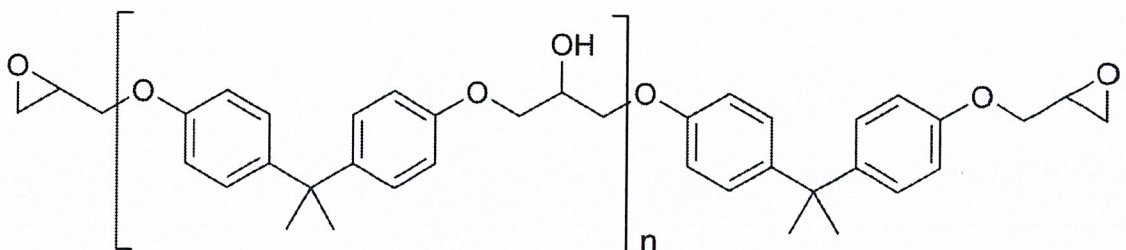

Figure 2.4 Structure of epoxies

Epoxies generally out-perform most other resin types in terms of mechanical properties and resistance to environmental degradation, that leads to their almost use in aircraft components. As a laminating resin their increased adhesive properties and resistance to water degradation make these resins ideal for use in applications such as boat building.

Epoxies are cured by a 'hardener' rather than a catalyst. The hardener, often an amine, is used to cure the epoxy by an 'addition reaction' where both materials take place in the chemical reaction. The chemistry of this reaction means that there are usually two epoxy sites binding to each amine site. This forms a complex three-dimensional molecular structure.

2.1.3 Fiberglass

A fiberglass is a form of fiber-reinforced plastic where glass fiber is the reinforced plastic. The glass fiber is usually flattened into a sheet, randomly arranged or woven into a fabric. According to the usage of the fiberglass, the glass fibers can be made of different types of glass.

It is cheaper and more flexible than carbon fiber, and stronger than many metals by weight. Moreover, fiberglass can be molded into complex shapes. Due to High Tensile Strength, Dimensional Stability, Low elongation under load, High Heat Resistance, Fire Resistance, Good Thermal Conductivity, Good Chemical Resistance, and others, fiberglass is widely used in bathtubs, boats, aircraft, roofing, and other applications.

2.1.4 Composite materials

A composite material is a material that made from two or more materials with significantly different physical or chemical properties. When combined all material, composite will have different characteristics from the individual components. The individual components remain separate and distinct within the finished structure, differentiating composites from mixtures and solid solutions.

The main advantage of this composite materials is lightweight and strong. Choosing of appropriate combination of matrix and reinforcement material makes a new material that exactly gets the requirements of application. Composites also have design

flexibility because many of them can be molded into complex shapes. But the disadvantage is the cost. Although the resulting product is more efficient, the raw materials are often expensive.

2.1.5 Adhesion properties

Adhesion is the tendency of dissimilar particles or surfaces to cling to one another (cohesion refers to the tendency of similar or identical particles or surfaces to cling to one another). The following Figure shown that the particles have adhesion with surfaces more than cohesion of its particles.

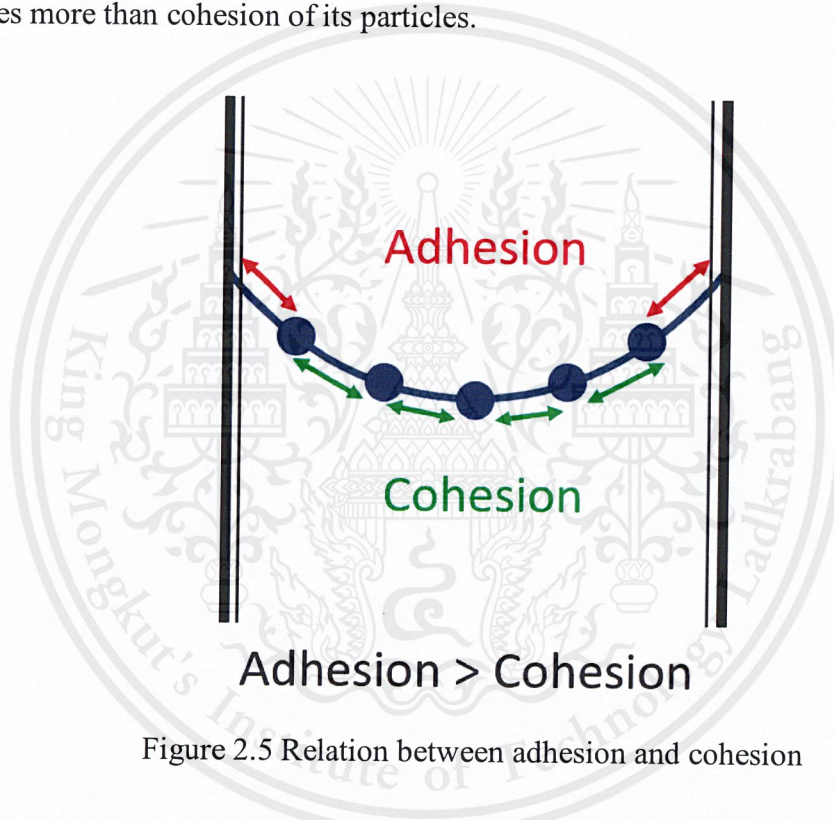

Figure 2.5 Relation between adhesion and cohesion

Adhesion also refers to hydrophilic properties when the particles is water. If the water and surface have a good adhesion, the water will be well disperse on the surface. It is mean that the surface have a hydrophobic properties. On the other hand, If the surface have a hydrophobic properties, the water will not well disperse on the surface. So there are cohesion more than adhesion, then occurring the drop of water on the surface. In this case, hydrophilic and hydrophobic properties can analyzt from contact angle measurement. The following Figure show that hydrophilic surface have a good disperse of water more than hydrophobic surface.

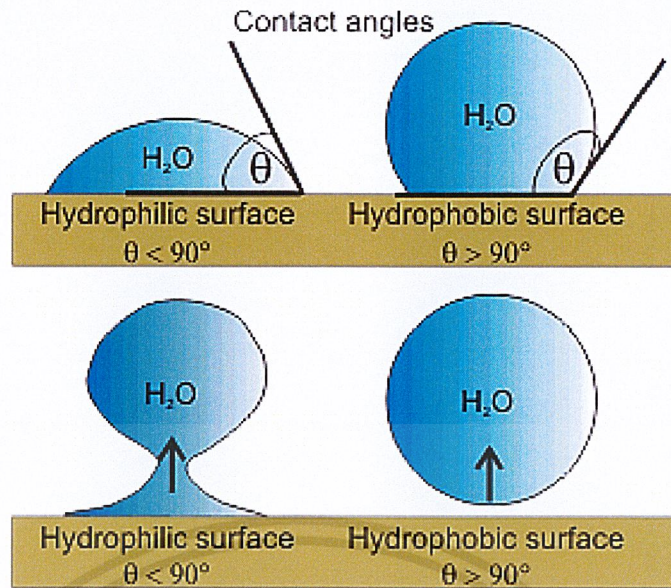

Figure 2.6 Relation between hydrophilic surface/ hydrophobic surface with contact angle.

2.1.6 Tensile testing analysis

In this work, ASTM D638 is used for tensile test methods for resin material. Sample should be prepared in dumbbell shape. The variable in figure 2.7 can be used the value in the following table 2.1.

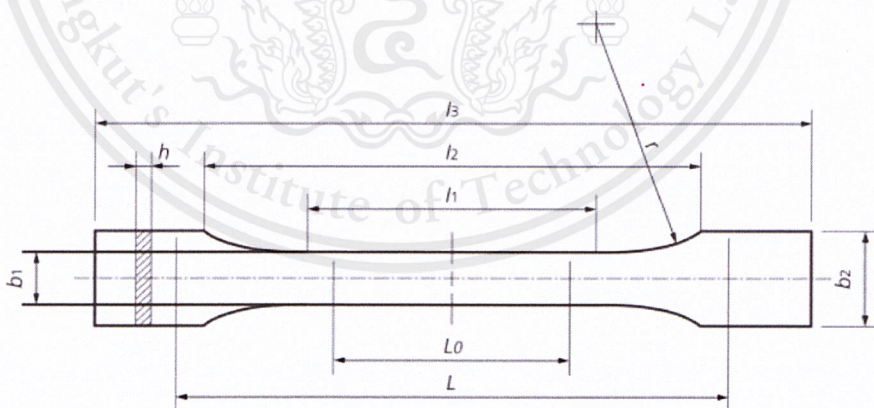

Figure 2.7 Example of the samples in dumbbell shape

Table 2.1 ASTM D638 Specimen Dimensions

Size	Type I	Type II	Type III	Type IV	Type V
Full length, l_3	165	185	165	115	-
Parallel length, l_2	57	57	57	33	63.5
Gauge length, l_1	50	50	50	25	-
Parallel section width, $strong_1$	13	6	19	6	7.62
Thickness, h	7 mm or less Recommend 3.2±0.4 mm		7mm to 14mm	4mm or less	
Grip section width, $strong_2$	19	19	29	19	9.53
Distance between grips	115	135	115	65	25.4

The test method involves placing the test sample in the testing machine, then slowly extending it until it fractures. During this testing, the elongation of the gauge section is recorded against the applied force by computer. The data is manipulated so that it is not specific to the geometry of the test sample. The elongation measurement is used to calculate the engineering strain, ϵ , by using the following equation

$$\epsilon = \frac{\Delta L}{L_0} = \frac{L - L_0}{L_0}$$

where

ϵ is engineering strain (Pa)

ΔL is the change in gauge length (m)

L_0 is the initial gauge length (m)

L is the final length. (m)

The force measurement is used to calculate the engineering stress, σ , by using the following equation

$$\sigma = \frac{F_n}{A}$$

where σ is engineering stress (Pa)
 F is the tensile force (N)
 A is the nominal cross-section of the specimen. (m²)

The machine does these calculations as the force increases, so that the data points can be graphed into a stress–strain curve as Figure 2.8.

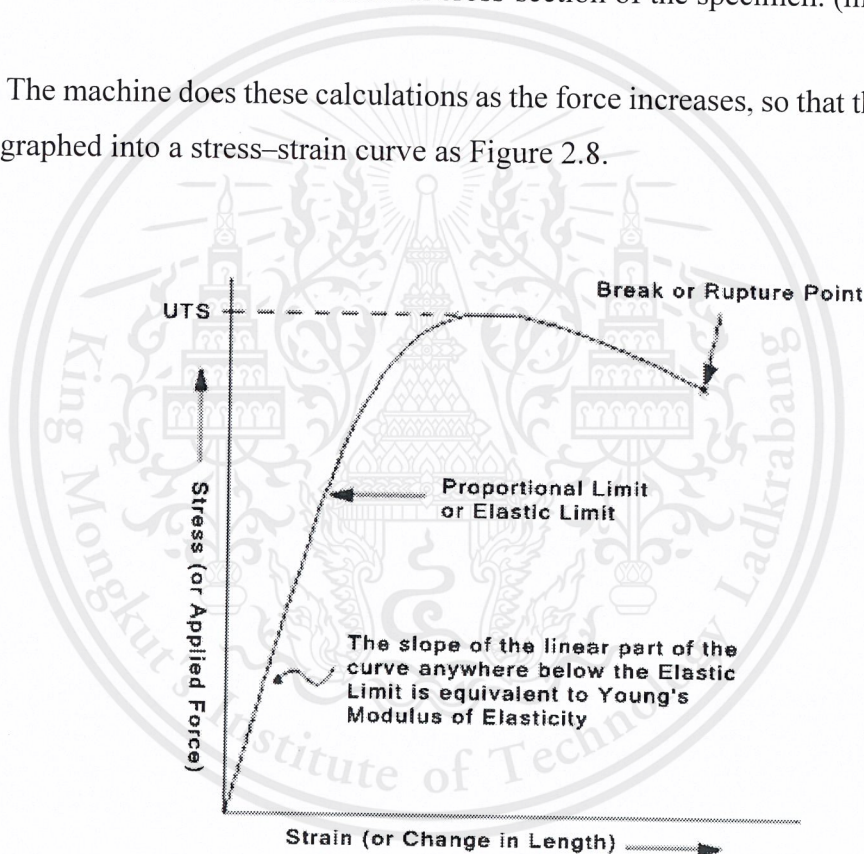

Figure 2.8 Example of the graph between stress and strain

2.1.7 Izod impact testing analysis

In this work, ASTM D256 is used for Izod impact testing methods for resin material. Sample have to prepare in rectangle with notch. The following Figure shown the dimension of Izod-Type Test sample. The variable in figure 2.9 can be used the value from following Table 2.2.

This material is reserved for educational use only, not allowed for commercial use.

Forbidden to modify the content, and cite the document when use

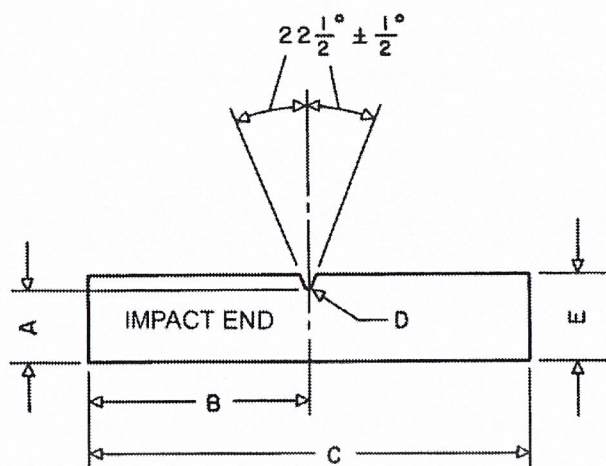

Figure 2.9 Dimensions of Izod-Type Test Specimen

Table 2.2 ASTM D256 Specimen Dimensions

A	10.16 ± 0.05 mm
B	31.8 ± 1.0 mm
C	63.5 ± 2.0 mm
D	$0.25R \pm 0.05$ mm
E	12.70 ± 0.20 mm

Molded samples will have a width between 3.0 and 12.7 mm. and notching will be done on a milling machine.

2.2 Literature Review

Rail way transportation system have been improve for many years. Nowadays, High-speed train are widely used around the world. The analysis of the recorded data indicated that the amplitude of vertical stresses, vertical deflections and strains caused by train axles were amplified with train speed. The train speed effect on both stress and strain was significantly attenuated. For this reason, material that was used for body of train have to be light weight and strong. [11]

Titanium dioxide was added into this composite. The effect of particle dispersion situation on the mechanical properties of nanocomposites has been studied. Tensile strength TiO_2 effect to Tensile strength because of plasticizing behavior of TiO_2 into epoxy. [12]

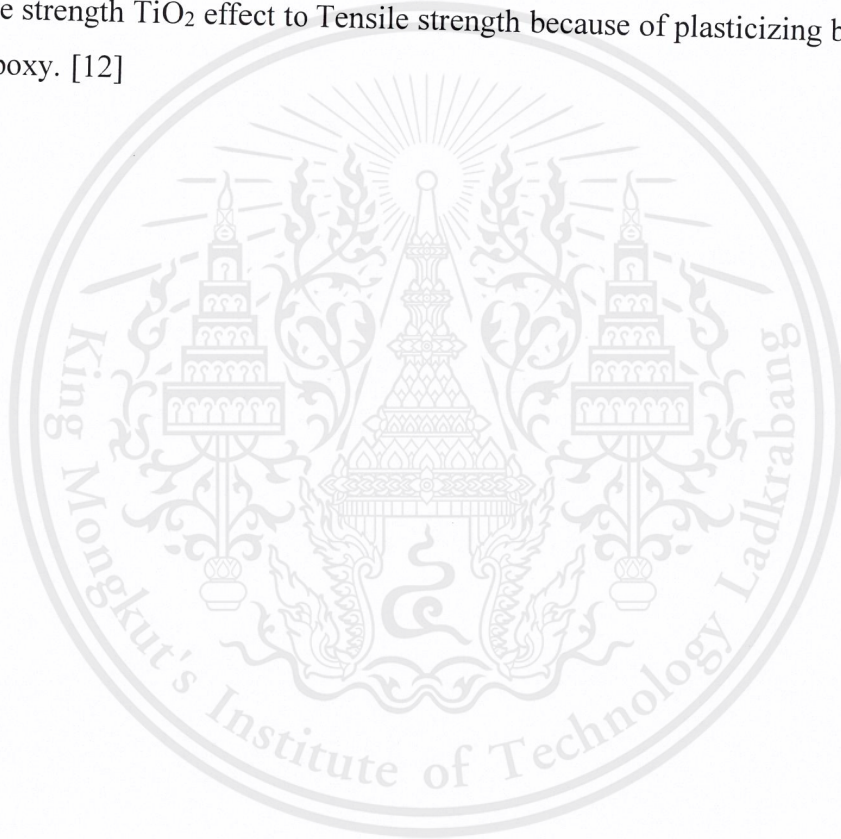

CHAPTER III

RESEARCH METHODOLOGY

This work focuses on the titanium dioxide particles in epoxy resin that coated on the plastic with fiberglass fabric to improve the adhesion properties. The increasing of titanium dioxide particles will significant increasing of adhesion properties, But this increasing also effects the other properties of composites too. For this reason, mechanical properties like tensile strength, impact factor of composite are required to study. The steps in this experiment and study are as follows.

3.1 Composites preparation

3.1.1 chemical and material

1. Polyethylene sheet
2. Fiberglass fabric
3. Epoxy resin
4. Hardener
5. Titanium dioxide (TiO₂) particle

3.1.2 Equipment and apparatus

1. Beaker
2. Analytical balance
3. Pipette
4. Graduated cylinder
5. Stirring rod
6. Oven
7. Wash Bottle
8. Forcep stainless
9. Filtering funnel
10. Nitrile glove
11. Sandpaper
12. Cutter

13. Watch glass
14. Nitrile glove

3.1.3 Procedures

1. Preparation of Epoxy resin with Titanium dioxide

1. Prepare the mixture of epoxy resin and hardener at ratio of 100 : 54 by weight respectively.
2. Add titanium dioxide for 1 %wt. into the mixture, then mixed to homogenous solution.

2. Composites coating

1. Cut polyethylene sheet into 1 dumbbell shape and 2 rectangles shape. Sized of workpieces are based on American Society of Testing and Materials (ASTM) for tensile testing analysis (ASTM D638), Izod impact testing analysis (ASTM D256), and contact angle analysis, respectively.
2. Prepare the work surface to be coated. Wash and polish with brush to remove the dirt, then dry at room temperature.
3. Use sandpaper polish the polyethylene sheet to make it rough.
4. Dip fiberglass fabric into the epoxy solution that prepared until the solution seeps into the fiberglass surface. Then use the fiberglass impregnated with this solution coated on polyethylene sheet.
5. Put the composite on the glass or ceramic and bring into oven at 50 °C for 3 hours.

3. Comparison of the amount of titanium dioxide particles

1. Repeat the above steps, but varying the titanium dioxide particles from 1 %wt. to 2 %wt., 3 %wt., 4 %wt., 5 %wt. and no titanium dioxide particles for each experimental.
2. Prepare 1 set of polyethylene in 1 dumbbell shape and 2 rectangles shape without coating.

3.2 Study of composites properties

3.2.1 Adhesion properties

1. Bring the samples from previous steps in contact angle measurement.
2. Record the angle, θ (deg) for each samples.
3. Plot graph of the relationship between angle and the amount of titanium dioxide particles coated on composite.

3.2.2 Tensile properties

1. Bring the samples from previous steps in Tensile Testing Machine.
2. Record the data and graph of relationship between stress and strain from the computer for each samples.
3. Plot graph of the relationship between tensile and the amount of titanium dioxide particles coated on composite.

3.2.3 Izod impact properties

1. Bring the samples from previous steps in Izod impact Testing Machine.
2. Record the impact value for each samples.
3. Plot graph of the relationship between impact and the amount of titanium dioxide particles coated on composite.

CHAPTER IV

RESULTS AND DISCUSSIONS

This work aims to study the amount of titanium that affects to adhesion properties and mechanical properties. For the adhesion properties, contact angle analysis is used to analyze this properties. Contact angle shows the ability of hydrophilic properties and hydrophobic properties between surface and water. If contact angle is high, it means they have cohesion properties more than adhesion properties. That refers to the hydrophobic properties.

For the mechanical properties, Tensile testing machine and Izod impact testing machine are used to study the tensile and impact factor of material respectively. Tensile testing machine works by placing the specimen in the machine between the grips and an extensometer. Then the machine records the displacement between its cross heads on which the specimen is held by itself. Once the machine is started, it begins to apply an increasing load on specimen. Throughout the tests the control system and its associated software record the load and extension or compression of the specimen until the specimen will torn apart.

Izod impact testing is a method to determine the impact resistance of materials. The results are expressed in energy lost per unit of thickness at the notch. Alternatively, the results are reported as energy lost per unit cross-sectional area at the notch.



Figure 4.1 Specimens for adhesion properties and mechanical properties testing

***The specimens can be used for contact angle meter measurement
before mechanical properties testing***

Contact Angle Measurement

6 specimen are used to apply this test. For 0 %wt. of TiO₂ to 1 %wt., 2 %wt., 3 %wt., 4 %wt., 5 %wt., the conditions used for this machine are following.

Table 4.1 Contact Angle test conditions.

Conditions	Value
Dosing Volume (μL)	5.000
Dosing Rate ($\mu\text{L/s}$)	1.00
Syringe Liquid	Water

The results for contact angle measurement show in Figure 4.2 The contact angle between surface and water are average by $(\text{CA left} + \text{CA right})/2$ that are 58.00 °, 62.45 °, 64.05 °, 71.10 °, 76.65 °, and 85.15 °.

The results show that the amount of titanium dioxide affects to adhesion properties significantly. When titanium dioxide was increased, contact angle also increased due to its surface morphology. The contact angle seems to depend on surface roughness. Rough surface seems to show a higher hydrophobic effect.

Table 4.2 Contact Angle between surface and water.

The amount of TiO ₂	Contact Angle		
	Left	Right	Average
0 %wt.	57.5 °	58.5 °	58.00 °
1 %wt.	62.5 °	62.4 °	62.45 °
2 %wt.	63.0 °	65.1 °	64.05 °
3 %wt.	70.2 °	72.0 °	71.10 °
4 %wt.	77.1 °	76.2 °	76.65 °
5 %wt.	58.2 °	85.1 °	85.18 °

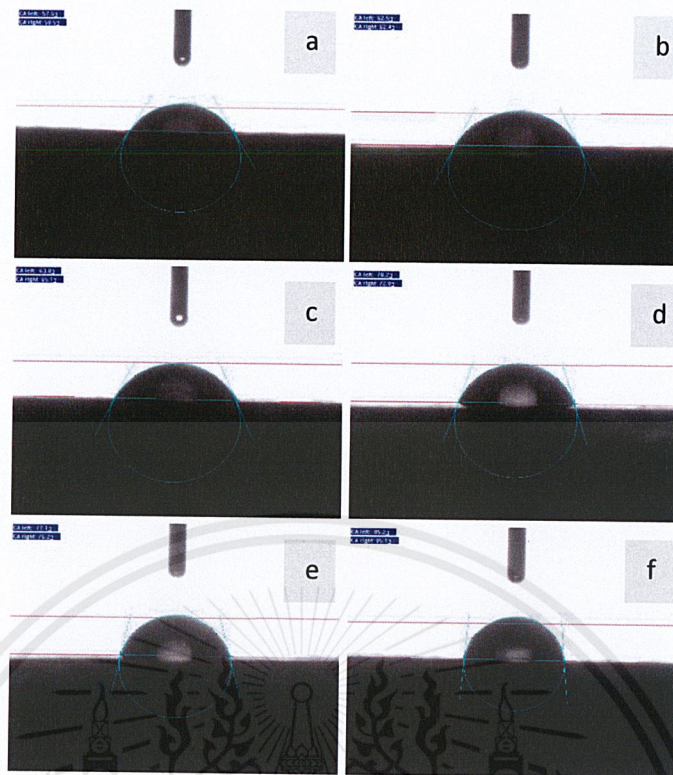

Figure 4.2 Contact angle between surface and water (a) 0 %wt. of TiO₂, (b) 1 %wt. of TiO₂, (c) 2 %wt. of TiO₂, (d) 3 %wt. of TiO₂, (e) 4 %wt. of TiO₂, (f) 5 %wt. of TiO₂.

Tensile Testing Machine

6 specimen are used to apply this test. For 0 %wt. of TiO₂ to 1 %wt., 2 %wt., 3 %wt., 4 %wt., 5 %wt. The conditions used for this machine are following.

Table 4.3. Tensile Testing Machine Conditions.

Conditions	Value
Product Name	Composite
Testing Machine	AG-X
Test Mode	Single
Test Type	Tensile
Speed	10 mm/min
Shape	Plate

This material is reserved for educational use only, not allowed for commercial use.

Forbidden to modify the content, and cite the document when use

The results from the Tensile Testing Machine not only show the graph between strain and stress but also compute elastic, yield point, max force, max stress, break stress, and break strain as shown in table 4.4. Figure 4.3 shows the relationship between stress and strain. Plotting the graph between the amount of titanium dioxide and Elastic & the amount of titanium dioxide and Yield point as shown in figure 4.4 and 4.5 respectively.

Graph between stress and strain have a trend to increase as a linear that refer to Hook's law until yield point. After that, fiber glass coated on the material brakes until all of them separate from each other. Then, graph decreases.

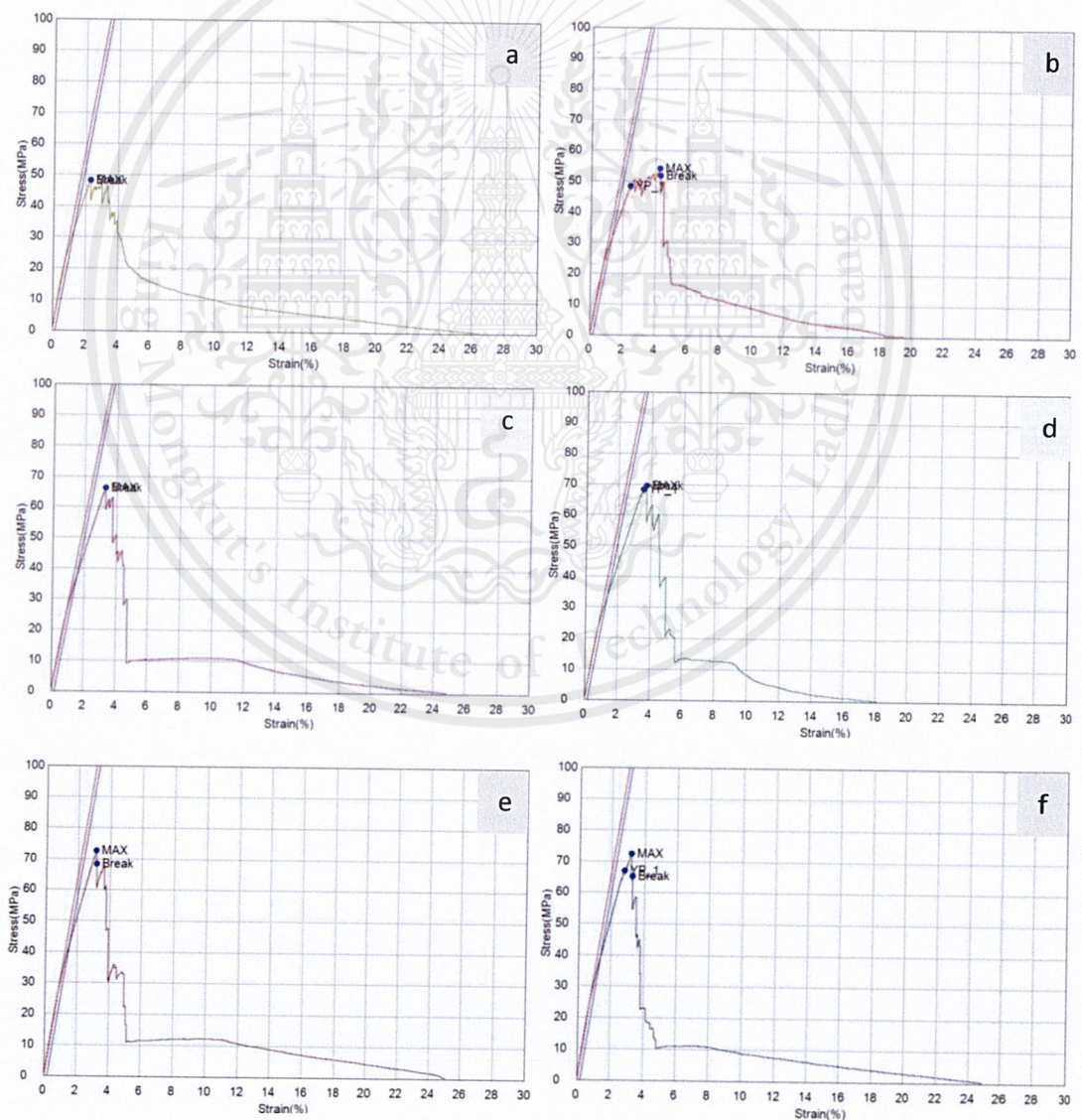

Figure 4.3 Relationship between stress and strain (a) 0 %wt. of TiO₂, (b) 1 %wt. of TiO₂, (c) 2 %wt. of TiO₂, (d) 3 %wt. of TiO₂, (e) 4 %wt. of TiO₂, (f) 5 %wt. of TiO₂

This material is reserved for educational use only, not allowed for commercial use.

Forbidden to modify the content, and cite the document when use

Table 4.4 Data processing items.

Name	Elastic	Yield Point	Max force	Max stress	Break stress	Break strain
Parameters	Stress 10-20 MPa	0.1%	Calc. at Entire Areas	Calc. at Entire Areas	Sensitivity: 10	Sensitivity: 10
Units	GPa	MPa	N	MPa	MPa	%
0 %wt.	3.33651	48.4559	6020.51	54.2366	51.8384	4.28724
1 %wt.	3.25271	48.8462	5973.24	72.5392	68.4620	3.15199
2 %wt.	2.09070	67.0881	5747.72	66.3264	66.3264	3.30768
3 %wt.	2.86097	67.8462	5726.43	69.5145	69.5145	3.30768
4 %wt.	2.79955	68.3933	5077.09	72.5126	65.3426	3.26832
5 %wt.	2.79011	73.4983	4307.00	48.3389	48.3389	2.2471

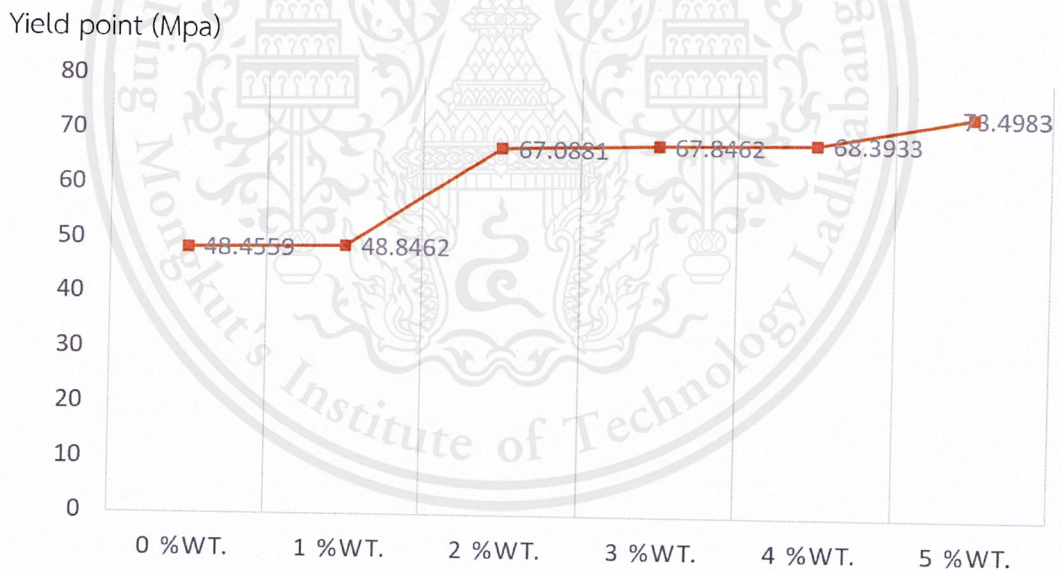

Figure 4.4 Relationship between the amount of titanium dioxide and Yield point



Figure 4.5 Relationship between the amount of titanium dioxide and Elastic

It was found that the elastic of the material decreased when the amount of TiO₂ was increased. Decreasing is not significant. Yield point of material increased when the amount of TiO₂ was increased. However, at 2 %wt. of TiO₂, the increasing amount of TiO₂ is not significant.

The reason for this effect can be explained as particle loading increases. The resulting composites seem to see more and more particle to particle interaction rather than the intended particle to polymer interaction. Particle to particle interaction leads to agglomerated particles and affects to mechanical properties.

Izod Impact Testing Machine

6 specimen are used to apply this test. For 0 %wt. of TiO₂ to 1 %wt., 2 %wt., 3 %wt., 4 %wt., 5 %wt. The conditions used for this machine are following.

Table 4.5 Izod Impact Testing Machine Conditions

Conditions	Value
Izod	3.46 m/s
Hammer	2.75 J

This material is reserved for educational use only, not allowed for commercial use.

Forbidden to modify the content, and cite the document when use

A test specimen having a V-shaped notch is fixed vertically, and the specimen is broken by striking it from the same side as that of the notch by the use of the hammer. The fracture energy is determined from the swing-up angle of the hammer and its swing-down angle. The Izod impact value (J/m^2 , kJ/m^2) is calculated by dividing the fracture energy by the width of the specimen. The Izod impact value of each specimen is in following table.

Table 4.6 Izod Impact Testing data

Specimens	Width	Thickness	E (kJ/m^2)	Angle
0 %wt.	10.20	3.19	83.5925	3.45 °
1 %wt.	10.20	3.19	83.5925	4.95 °
2 %wt.	10.20	3.19	83.5925	3.55 °
3 %wt.	10.20	3.20	83.3313	3.75 °
4 %wt.	10.30	3.20	72.1200	23.30 °
5 %wt.	10.30	3.20	56.1944	20.30 °

According to the values from the test to the plot graph between the amount of titanium dioxide and Izod Impact Value, It was found that the amount of titanium dioxide do not affect to Izod Impact Value in small quantities of titanium dioxide. After that, the energy decreased when the amount of titanium dioxide are increased as shown in figure 4.6.

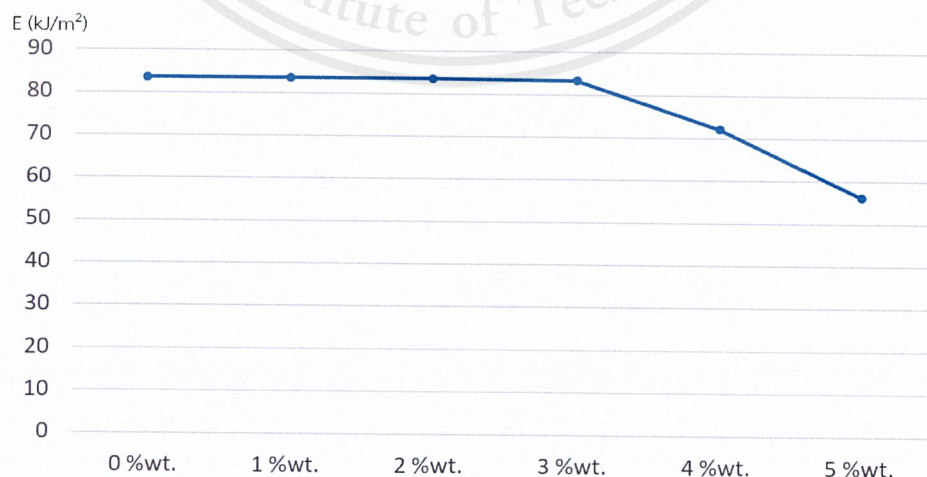

Figure 4.6 Relationship between the amount of titanium dioxide and Izod Impact Value

This material is reserved for educational use only, not allowed for commercial use.

Forbidden to modify the content, and cite the document when use

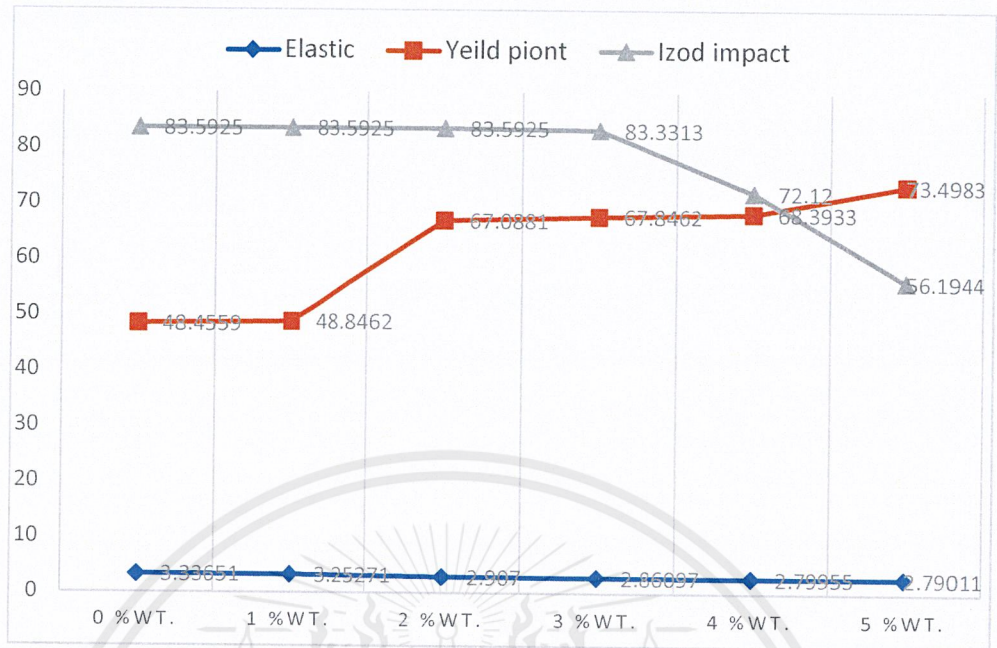

Figure 4.7 Relationship between the amount of titanium dioxide and Elastic & Yield Point & Izod Impact Energy

From the previous test, the contact angle increased by the increasing of the amount of titanium dioxide. It was found that the optimum point is at 2%wt titanium dioxide because the increasing of TiO_2 do not affect in better way. At 2%wt. of TiO_2 have contact angle, elastic, yield point, and Izod impact energy equal to 64.05° , 2.097 GPa, 67.0881MPa, and 83.5925 kJ/m² respectively.

CHAPTER V

This material is reserved for educational use only, not allowed for commercial use.

Forbidden to modify the content, and cite the document when use

CONCLUSIONS

5.1 CONCLUSIONS

In this research, it is expected to study the effect of titanium dioxide to adhesion properties and mechanical properties. The experiment of this research begins with the preparing the specimens for contact angle measurement, tensile testing machine, and Izod impact testing machine. For tensile testing machine, and Izod impact testing machine, the shape of specimens refer by ASTM D638 and ASTM D256 respectively. Then, coating the composite by fiberglass and epoxy that vary the amount of titanium dioxide from 0 %wt. to 1 %wt., 2 %wt., 3 %wt., 4 %wt., 5 %wt. The result from the contact angle measurement shows that the contact angle increased by increasing of titanium dioxide due to its surface morphology. Rough surface shows an effect of higher hydrophobic. For mechanical properties testing, it was found that an increase of titanium dioxide affects to decreasing of elastic and Izod impact energy and increasing of yield point. For elastic, the decreasing is non-significant. The reasons of this effect is agglomerated particles that occur in the composite. Finally, when considering the significant value of contact angle, Izod impact, yield point. It was found that the optimum point is at 2%wt titanium dioxide is. that have contact angle, elastic, yield point, and Izod impact energy equal to 64.05 °, 2.097 GPa, 67.0881MPa, and 83.5925 kJ/m² respectively.

5.2 SUGGESTIONS

- 1) Substitute the titanium dioxide particle by titanium dioxide nanoparticle to increase distribute ability.
- 2) Study the effect of fiberglass to mechanical properties by varying the layer.

REFERENCES

- [1] Dr. Balkees M.Deya'a*, Dr.Fawziea M. Hussien** & Intihah Gatia Dway**, "Studying the Impact Strength of (Epoxy with TiO₂ and MgO) Composite", Eng. & Tech. Journal, Vol. 29 , No.10 , 2011
- [2] Rana Mahdi Salih, "Effect of Water on Some Mechanical Properties of Epoxy Blends Reinforced With Different Weight Fractions of Nano Titanium Oxide and Nano Silica" , Iraqi Journal of Science, 2017, Vol. 58, No.3C, pp: 1675-1682
- [3] Bu-Ahn Kim and Chang-Kwon Moon, "Study on Mechanical and Thermal Properties of TiO₂/Epoxy Resin Nanocomposites", International Journal of Ocean System Engineering 3(2) (2013) 102-110
- [4] "Titanium dioxide" [online]. Available: https://pubchem.ncbi.nlm.nih.gov/compound/titanium_dioxide#section=Top. [Accessed: 08-Dec-2018].
- [5] วีระชัย แสงฉาย, "Photocatalytic Properties of Fe-doped TiO₂ Thin Films Coated on Glass Fiber", Industrial Technology Lampang Rajabhat University Journal
- [6] Pedro Magalhães, Luísa Andrade, Olga C. Nunes and Adélio , "TITANIUM DIOXIDE PHOTOCATALYSIS: FUNDAMENTALS AND APPLICATION ON PHOTOINACTIVATION", Rev.Adv. Mater. Sci. 51 (2017) 91-129
- [7] Xiwen Liu, Yao Tong, Jia Chen, "Surface Curing and Properties of Titanium Dioxide Self - Cleaning Ceramics", Ceramic Sciences and Engineering (2018)
- [8] "Composite materials", Composite materials – page 1 of 3, Index 4.3.1
- [9] "ASTM D638" [online]. Available: <https://www.shimadzu.com/an/industry/petrochemicalchemical/n9j25k00000pyu05.html> . [Accessed: 08-Dec-2018].
- [10] Standard Test Methods for Determining the Izod Pendulum Impact Resistance of Plastics 1
- [11] Francisco Lamas-Lopez a, *, Yu-Jun Cui a, Nicolas Calon b, Sofia Costa D'Aguiar c, Tongwei Zhang a, "Impact of train speed on the mechanical behaviours", 30 January 2017
- [12] N.Annlin Bezy*, A.Lesly Fathima*, "Effect of TiO₂ nanoparticles on Mechanical Properties of Epoxy-Resin System"



A: Properties of materials

1A: Technical data sheet ___ Epoxy resin BE-333

BE-333 is a liquid. Unmodified bisphenol A-epichlorohydrin epoxide resin which is light straw-color has medium viscosity. BE-333 is one of the most standard liquid resin which can be cured with amine, anhydride, polyamine, or other hardeners depending upon desired and properties. The products have excellent chemical resistance, superior physical and electrical properties, maximum heat resistance and excellent adhesion. BE-333 can be cured at room or elevated temperatures depending upon choice of hardener.

Specification

Weight per Epoxy Equivalent (WPE)	182-192
Viscosity, Brookfield, cps, 25°C	11,000-15,000
Color, (APHA)	< 30
Specific Gravity	1.15-1.18
Nonvolatile %wt.	99.7 min
Chlorine, Hydrolyzable, ppm	< 1,000

Application

Protective Coating

Casting, Potting & Encapsulation for Electrical Components

Laminating

Tooling

Civil Engineering

Adhesive

<u>Package</u>	220 kgs net weight in new iron drum
<u>Storage</u>	BE-333 should be stored in dry conditions away from the resin may have a storage life of at least one year.

2A: Technical data sheet ___ EP-HARDENER 17

Chemical Type

Cycloaliphatic polyamine adduct

H-equivalent weight (f.o.d.) 100 g/mol

Form of Delivert (f.o.d.) 100%

Special Properties and Use

Relatively low yellowing – tendency.

With liquid epoxy resins for self-levelling flooring compounds casting compounds and laminates.

Distinguishing Features

EP-HARDENER 17 is lower in reactivity than

Suggested Uses and Processing

EP-HARDENER 17 is a modified polyamine with very low viscosity, for use together with liquid epoxy resins for flooring compounds with good chemical resistance and low yellowing tendency.

For thin walled laminates a post cure of 2-3 hours at 40-50 °C is necessary prior to deforming.

Mixing Ratio and pot Lire

A blend of

100 g EP-HARDENER

54 g EH-HARDENER 17

Starts to gel at 23 °C after approx.
45-60 minutes.

Product Data

Determined per batch:

Dynamic Viscosity 90-120 mPa.s (DIN 3219, at 500 1/s;
23°C)

Amine Value 300-350 mg KOH/g (DIN 16945/5.6)

Iodine Colour Number EP-HARDENER 17 is lower in
reactivity than

Not continually determined

Dynamic Viscosity: 80-100 mPa.s (DIN 3219, at 500 1/s;
23°C)

Density, 20°C: 1.00 approx. g/cm^3 (DIN 2811-2)

Flash point (°C) > 96 °C (DIN 2719, Fensky-Martens)

Storage Stability

At temperature up to 25°C storage stability packed in original containers amounts to at least 365 days.

Safety At Work and Environmental Protection

When handling and processing epoxy resins and hardeners, the rules and regulations established by local authorities should be observed. A material Safety Data Sheet is available on request.

B: Specimen preparation

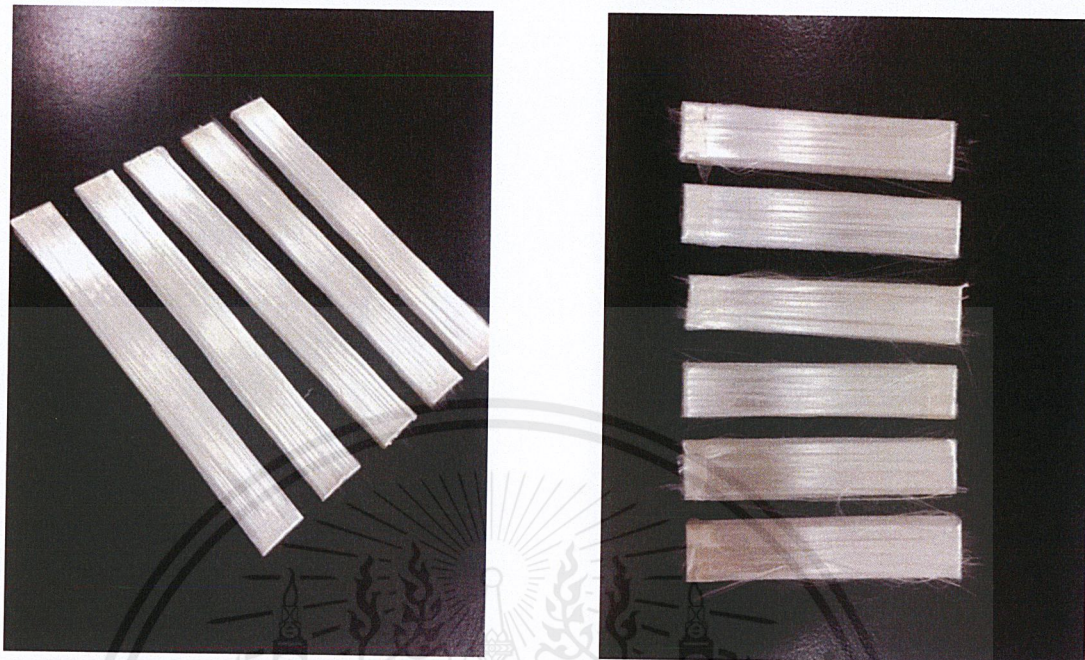

Figure B1. Specimens for adhesion properties and mechanical properties testing (before coating).

C: Tensile Testing method

0%wt.			1%wt.		
Time	Force	Stroke	Time	Force	Stroke
sec	N	mm	sec	N	mm
0	-6.35783	0	0	-5.80152	0
0.01	-6.35783	4.17E-05	0.01	-5.80152	6.25E-05
0.02	-6.35783	0.000438	0.02	-5.80152	0.000438
0.03	-6.37372	0.001271	0.03	-5.80152	0.001271
0.04	-6.40551	0.002354	0.04	-5.80152	0.002354
0.05	-6.40551	0.003625	0.05	-5.8492	0.003625
0.06	-6.40551	0.004938	0.06	-5.8492	0.004938
0.07	-6.40551	0.006313	0.07	-5.8492	0.006292
0.08	-6.40551	0.00775	0.08	-5.8492	0.00775
0.09	-6.40551	0.009292	0.09	-5.8492	0.009313
0.1	-6.40551	0.010938	0.1	-5.8492	0.010958
0.11	-6.40551	0.012604	0.11	-5.8492	0.012646
0.12	-6.40551	0.014292	0.12	-5.8492	0.014333
0.13	-6.40551	0.015979	0.13	-5.8651	0.016021
0.14	4.990896	0.017667	0.14	13.28786	0.017688
0.15	15.7992	0.019333	0.15	20.01127	0.019375

This material is reserved for educational use only, not allowed for commercial use.

Forbidden to modify the content, and cite the document when use

0.16	20.18611	0.021021	0.16	25.43131	0.021042
0.17	25.71742	0.022688	0.17	30.4381	0.022708
0.18	31.20104	0.024354	0.18	36.16015	0.024375
0.19	36.97078	0.026021	0.19	41.77094	0.026042
0.2	42.42261	0.027708	0.2	47.28635	0.027708
0.21	47.04793	0.029396	0.21	53.99386	0.029417
0.22	52.67461	0.031104	0.22	59.81128	0.031104
0.23	57.53835	0.032792	0.23	65.0247	0.032813
0.24	62.43388	0.0345	0.24	69.9679	0.0345
0.25	66.58236	0.036167	0.25	74.72038	0.036167
0.26	71.28716	0.037813	0.26	80.34706	0.037854
0.27	75.68995	0.0395	0.27	86.1009	0.0395
0.28	79.91791	0.041146	0.28	90.94874	0.041167
0.29	84.79754	0.042792	0.29	95.68533	0.042813
0.3	89.15266	0.044458	0.3	100.4219	0.044458
0.31	93.92103	0.046104	0.31	105.3333	0.046104
0.32	98.41919	0.047771	0.32	110.5467	0.047771
0.33	101.916	0.049417	0.33	115.4105	0.049438
0.34	106.0486	0.051083	0.34	120.004	0.051104
0.35	110.6898	0.052771	0.35	124.6134	0.052771
0.36	115.3946	0.054438	0.36	128.9527	0.054438
0.37	119.6384	0.056104	0.37	134.4999	0.056125
0.38	124.836	0.057771	0.38	139.3477	0.057792
0.39	128.6348	0.059438	0.39	144.1002	0.059458
0.4	132.2746	0.061104	0.4	148.1851	0.061104
0.41	136.6933	0.062771	0.41	152.7309	0.062771
0.42	140.8418	0.064417	0.42	157.1973	0.064417
0.43	145.4512	0.066083	0.43	162.4743	0.066083
0.44	150.1401	0.06775	0.44	167.64	0.06775
0.45	154.3204	0.069438	0.45	171.725	0.069438
0.46	159.2477	0.071125	0.46	176.8748	0.071125
0.47	163.126	0.072813	0.47	181.3889	0.072813
0.48	166.8453	0.0745	0.48	186.1731	0.074521
0.49	171.0256	0.076188	0.49	190.9733	0.076208
0.5	174.9992	0.077875	0.5	195.7099	0.077875
0.51	180.006	0.079521	0.51	199.9378	0.079542
0.52	185.7281	0.081167	0.52	204.3247	0.081188
0.53	189.9719	0.082813	0.53	209.7448	0.082833
0.54	194.1045	0.084458	0.54	214.5926	0.084479
0.55	197.7762	0.086104	0.55	219.504	0.086125
0.56	201.9564	0.08775	0.56	223.1121	0.087771
0.57	206.693	0.089417	0.57	227.3719	0.089417
0.58	211.064	0.091083	0.58	232.7124	0.091083
0.59	215.7211	0.09275	0.59	236.8291	0.09275
0.6	220.1716	0.094417	0.6	240.914	0.094417
0.61	223.5889	0.096104	0.61	245.4917	0.096104
0.62	228.2619	0.097771	0.62	250.6574	0.097771
0.63	232.0607	0.099438	0.63	254.3926	0.099438

This material is reserved for educational use only, not allowed for commercial use.

Forbidden to modify the content, and cite the document when use

0.64	236.241	0.101104	0.64	259.5583	0.101104
0.65	241.2478	0.102771	0.65	264.3267	0.102771
0.66	245.7778	0.104417	0.66	268.5865	0.104438
0.67	250.4349	0.106083	0.67	273.2277	0.106083
0.68	253.9476	0.107729	0.68	278.0438	0.10775
0.69	258.557	0.109417	0.69	282.1128	0.109417
0.7	262.9757	0.111083	0.7	287.1513	0.111083
0.71	266.8063	0.112771	0.71	291.0455	0.112771
0.72	271.1932	0.114458	0.72	295.5755	0.114458
0.73	275.6913	0.116146	0.73	300.169	0.116167
0.74	279.4266	0.117833	0.74	303.6976	0.117833
0.75	283.5909	0.119521	0.75	307.7666	0.119521
0.76	287.4374	0.121167	0.76	313.1707	0.121188
0.77	292.2058	0.122813	0.77	318.2411	0.122833
0.78	296.5927	0.124479	0.78	322.5486	0.1245
0.79	300.6458	0.126125	0.79	326.9037	0.126146
0.8	305.0804	0.127792	0.8	331.7038	0.127792
0.81	309.4355	0.129438	0.81	336.8696	0.129438
0.82	313.1231	0.131104	0.82	340.9386	0.131104
0.83	317.4623	0.132771	0.83	345.087	0.132771
0.84	322.0399	0.134438	0.84	349.1879	0.134438
0.85	326.1407	0.136104	0.85	353.3204	0.136125
0.86	330.5117	0.137792	0.86	357.9934	0.137792
0.87	334.1993	0.139458	0.87	363.1433	0.139458
0.88	338.2365	0.141125	0.88	367.8958	0.141125
0.89	343.2592	0.142771	0.89	371.9171	0.142792
0.90	346.6924	0.144417	0.90	376.1133	0.144438
0.91	349.6965	0.146083	0.91	380.0074	0.146083
0.92	354.1311	0.147729	0.92	384.7122	0.14775
0.93	358.4226	0.149396	0.93	389.0197	0.149396
0.94	363.191	0.151063	0.94	392.6754	0.151063
0.95	367.3712	0.152729	0.95	398.2862	0.152729
0.96	370.868	0.154417	0.96	403.1499	0.154417
0.97	375.1437	0.156104	0.97	406.758	0.156104
0.98	379.3716	0.157792	0.98	411.3515	0.157813
0.99	383.6632	0.1595	0.99	416.6921	0.1595
1.00	387.8593	0.161167	1.00	421.5558	0.161167
1.01	392.2303	0.162813	1.01	425.5613	0.162833
1.02	396.2676	0.1645	1.02	429.9005	0.1645
1.03	401.2426	0.166125	1.03	434.7801	0.166146
1.04	405.0891	0.167792	1.04	439.3101	0.167813
1.05	409.2534	0.169438	1.05	443.5221	0.169458
1.06	412.782	0.171104	1.06	447.7024	0.171104
1.07	417.3597	0.17275	1.07	453.3927	0.17275
1.08	421.7784	0.174417	1.08	457.0961	0.174417
1.09	424.6871	0.176083	1.09	460.6247	0.176083
1.10	428.7402	0.17775	1.10	465.3613	0.177771
1.11	433.0635	0.179438	1.11	469.3985	0.179458

This material is reserved for educational use only, not allowed for commercial use.

Forbidden to modify the content, and cite the document when use

1.12	436.9895	0.181125	1.12	474.2463	0.181125
1.13	441.0903	0.182792	1.13	478.8717	0.182792
1.14	445.6838	0.184438	1.14	483.0042	0.184458
1.15	450.023	0.186104	1.15	487.5978	0.186104
1.16	454.6483	0.18775	1.16	491.6509	0.187771
1.17	459.4644	0.189417	1.17	495.1636	0.189438
1.18	463.6924	0.191083	1.18	500.1863	0.191083
1.19	467.9203	0.19275	1.19	504.1281	0.19275
1.20	473.0701	0.194438	1.20	508.8329	0.194438
1.21	477.9498	0.196104	1.21	513.3629	0.196104
1.22	481.7168	0.197792	1.22	517.3047	0.197813
1.23	485.6745	0.1995	1.23	521.9142	0.1995
1.24	489.7118	0.201188	1.24	526.158	0.201188
1.25	494.7503	0.202854	1.25	530.2111	0.202854
1.26	499.1531	0.204521	1.26	534.2007	0.204521
1.27	502.8884	0.206146	1.27	539.0962	0.206167
1.28	506.7825	0.207792	1.28	543.7533	0.207813
1.29	511.3761	0.209458	1.29	547.4885	0.209458
1.30	516.3352	0.211104	1.30	551.4622	0.211104
1.31	520.7062	0.21275	1.31	556.1669	0.212771
1.32	525.4586	0.214396	1.32	558.9485	0.214417
1.33	529.7184	0.216063	1.33	563.0175	0.216063
1.34	533.549	0.217729	1.34	567.5316	0.217729
1.35	538.2697	0.219417	1.35	572.9835	0.219417
1.36	542.2433	0.221083	1.36	577.5611	0.221104
1.37	547.1071	0.222771	1.37	581.5824	0.222771
1.38	551.796	0.224438	1.38	585.3494	0.224438
1.39	555.261	0.226104	1.39	590.3562	0.226104
1.40	559.5208	0.227771	1.40	594.0596	0.227771
1.41	564.6705	0.229417	1.41	598.4307	0.229438
1.42	568.517	0.231083	1.42	602.754	0.231083
1.43	573.6987	0.23275	1.43	606.8707	0.23275
1.44	578.3558	0.234396	1.44	611.3052	0.234417
1.45	582.6155	0.236083	1.45	616.1849	0.236083
1.46	586.9388	0.237771	1.46	619.5704	0.237771
1.47	591.0079	0.239458	1.47	623.3851	0.239458
1.48	595.4106	0.241167	1.48	628.7734	0.241167
1.49	600.8148	0.242854	1.49	633.1603	0.242833
1.50	604.7726	0.244521	1.50	637.1657	0.244521
1.51	609.8748	0.246188	1.51	641.2188	0.246188
1.52	614.1822	0.247833	1.52	645.8123	0.247833
1.53	618.3784	0.2495	1.53	650.2311	0.2495
1.54	621.9069	0.251125	1.54	655.0948	0.251146
1.55	626.3097	0.252792	1.55	658.6711	0.252792
1.56	631.0622	0.254458	1.56	662.5652	0.254458
1.57	635.6875	0.256104	1.57	667.4926	0.256104
1.58	640.5989	0.257771	1.58	671.7205	0.257771
1.59	644.4613	0.259438	1.59	676.1551	0.259438

This material is reserved for educational use only, not allowed for commercial use.

Forbidden to modify the content, and cite the document when use

1.60	648.2601	0.261104	1.60	680.3036	0.261125
1.61	653.0921	0.262792	1.61	684.2772	0.262792
1.62	657.7809	0.264458	1.62	689.0774	0.264458
1.63	663.0262	0.266125	1.63	693.5756	0.266125
1.64	666.9839	0.267771	1.64	697.8194	0.267792
1.65	671.0847	0.269417	1.65	702.4765	0.269438
1.66	675.4557	0.271083	1.66	706.5137	0.271083
1.67	680.2082	0.272729	1.67	710.7099	0.27275
1.68	685.374	0.274396	1.68	715.2081	0.274396
1.69	690.1105	0.276063	1.69	719.3566	0.276063
1.70	694.402	0.277729	1.70	723.3779	0.277729
1.71	699.3929	0.279417	1.71	727.8919	0.279417
1.72	704.9879	0.281104	1.72	731.7702	0.281104
1.73	708.8979	0.282813	1.73	736.0618	0.282813
1.74	712.506	0.2845	1.74	740.544	0.2845
1.75	716.7816	0.286188	1.75	744.7084	0.286188
1.76	720.9778	0.287854	1.76	749.3178	0.287854
1.77	725.9687	0.2895	1.77	754.5948	0.2895
1.78	730.9119	0.291167	1.78	758.9817	0.291146
1.79	735.6962	0.292792	1.79	762.9395	0.292813
1.80	740.8937	0.294458	1.80	766.9449	0.294458
1.81	745.5349	0.296104	1.81	770.5052	0.296104
1.82	750.3669	0.297771	1.82	774.8922	0.297771
1.83	754.563	0.299417	1.83	780.4235	0.299417
1.84	758.5526	0.301083	1.84	783.8885	0.301083
1.85	762.7487	0.302771	1.85	787.7032	0.302771
1.86	767.8668	0.304438	1.86	792.2014	0.304458
1.87	772.4126	0.306125	1.87	796.8743	0.306125
1.88	777.0856	0.307792	1.88	801.3726	0.307792
1.89	781.9653	0.309438	1.89	806.0932	0.309458
1.90	786.8608	0.311083	1.90	810.4801	0.311104
1.91	790.7549	0.31275	1.91	814.1835	0.312771
1.92	795.0942	0.314417	1.92	818.9678	0.314417
1.93	800.3871	0.316083	1.93	823.164	0.316083
1.94	804.6786	0.31775	1.94	826.9469	0.31775
1.95	809.6695	0.319438	1.95	831.9537	0.319438
1.96	815.0895	0.321125	1.96	836.0863	0.321125
1.97	819.5877	0.322813	1.97	840.0281	0.322813
1.98	823.0527	0.324521	1.98	845.48	0.324521
1.99	827.3284	0.326208	1.99	849.9781	0.326208
2.00	831.7788	0.327875	2.00	853.7769	0.327875
2.01	836.3247	0.329521	2.01	858.1956	0.329542
2.02	840.6639	0.331167	2.02	862.3918	0.331188
2.03	845.925	0.332833	2.03	866.127	0.332833
2.04	849.7715	0.334458	2.04	871.1815	0.334479
2.05	854.1107	0.336104	2.05	875.4254	0.336125
2.06	857.4009	0.337771	2.06	880.003	0.337771
2.07	861.1202	0.339417	2.07	884.9621	0.339417

This material is reserved for educational use only, not allowed for commercial use.

Forbidden to modify the content, and cite the document when use

2.08	865.1097	0.341083	2.08	888.8881	0.341083
2.09	869.4808	0.34275	2.09	892.9094	0.34275
2.10	874.0584	0.344417	2.10	896.6287	0.344438
2.11	877.8413	0.346104	2.11	900.4593	0.346104
2.12	881.5606	0.347771	2.12	905.5773	0.347771
2.13	886.8058	0.349438	2.13	909.0742	0.349438
2.14	891.1609	0.351104	2.14	913.7471	0.351104
2.15	894.7849	0.35275	2.15	919.1513	0.352771
2.16	899.1241	0.354438	2.16	922.7753	0.354438
2.17	903.9879	0.356104	2.17	926.9555	0.356083
2.18	909.2331	0.35775	2.18	931.2153	0.35775
2.19	913.6677	0.359417	2.19	935.92	0.359417
2.20	918.6109	0.361083	2.20	940.1162	0.361083
2.21	923.1408	0.362771	2.21	944.6144	0.362771
2.22	927.5277	0.364458	2.22	948.7311	0.364479
2.23	932.2167	0.366146	2.23	952.8954	0.366167
2.24	936.4764	0.367833	2.24	956.9327	0.367854
2.25	941.3719	0.369521	2.25	960.9858	0.369521
2.26	945.5363	0.371188	2.26	966.4059	0.371188
2.27	950.5113	0.372813	2.27	970.5703	0.372833
2.28	955.7406	0.374479	2.28	974.7982	0.374479
2.29	959.1738	0.376125	2.29	978.8195	0.376146
2.30	963.7038	0.377792	2.30	983.0793	0.377792
2.31	968.4245	0.379438	2.31	987.3073	0.379458
2.32	972.6207	0.381104	2.32	991.9961	0.381104
2.33	976.944	0.38275	2.33	996.1764	0.382771
2.34	980.6315	0.384438	2.34	1000.913	0.384438
2.35	985.4634	0.386104	2.35	1004.744	0.386125
2.36	990.3907	0.387792	2.36	1009.21	0.387792
2.37	995.6519	0.389458	2.37	1013.724	0.389458
2.38	1000.182	0.391125	2.38	1018.572	0.391125
2.39	1004.346	0.392771	2.39	1022.339	0.392792
2.40	1008.828	0.394438	2.40	1026.408	0.394438
2.41	1013.486	0.396083	2.41	1031.001	0.396083
2.42	1017.634	0.397729	2.42	1035.309	0.39775
2.43	1021.226	0.399396	2.43	1040.332	0.399396
2.44	1026.026	0.401042	2.44	1044.226	0.401063
2.45	1030.938	0.402729	2.45	1048.183	0.402729
2.46	1036.31	0.404417	2.46	1051.569	0.404417
2.47	1040.109	0.406125	2.47	1055.718	0.406125
2.48	1044.48	0.407813	2.48	1060.12	0.407813
2.49	1049.248	0.4095	2.49	1064.92	0.4095
2.50	1053.254	0.411188	2.50	1069.752	0.411188
2.51	1057.482	0.412833	2.51	1074.219	0.412854
2.52	1062.25	0.4145	2.52	1077.525	0.414521
2.53	1066.494	0.416146	2.53	1081.991	0.416167
2.54	1070.849	0.417833	2.54	1086.744	0.417833
2.55	1075.236	0.419479	2.55	1090.908	0.419479

This material is reserved for educational use only, not allowed for commercial use.

Forbidden to modify the content, and cite the document when use

2.56	1078.987	0.421125	2.56	1096.233	0.421125
2.57	1084.073	0.422771	2.57	1099.777	0.422771
2.58	1088.317	0.424438	2.58	1103.163	0.424438
2.59	1092.609	0.426104	2.59	1108.106	0.426104
2.60	1097.552	0.427771	2.60	1112	0.427771
2.61	1102.209	0.429458	2.61	1115.751	0.429458
2.62	1105.913	0.431125	2.62	1119.916	0.431125
2.63	1110.236	0.432771	2.63	1124.97	0.432792
2.64	1114.75	0.434438	2.64	1128.817	0.434458
2.65	1119.328	0.436104	2.65	1133.235	0.436104
2.66	1123.81	0.43775	2.66	1137.813	0.43775
2.67	1128.006	0.439417	2.67	1141.596	0.439417
2.68	1132.361	0.441083	2.68	1146.126	0.441083
2.69	1137.082	0.44275	2.69	1149.956	0.44275
2.70	1141.596	0.444417	2.70	1154.264	0.444417
2.71	1144.87	0.446104	2.71	1158.81	0.446104
2.72	1149.177	0.447813	2.72	1162.91	0.447813
2.73	1154.01	0.4495	2.73	1167.488	0.4495
2.74	1158.889	0.451188	2.74	1171.462	0.451188
2.75	1164.405	0.452854	2.75	1174.959	0.452875
2.76	1168.299	0.454521	2.76	1179.266	0.454521
2.77	1172.527	0.456167	2.77	1183.621	0.456188
2.78	1176.882	0.457813	2.78	1187.515	0.457833
2.79	1180.569	0.459458	2.79	1191.632	0.459479
2.80	1184.654	0.461104	2.80	1196.686	0.461125
2.81	1189.327	0.462771	2.81	1200.851	0.462771
2.82	1193.253	0.464417	2.82	1204.697	0.464417
2.83	1197.084	0.466063	2.83	1209.243	0.466083
2.84	1201.9	0.46775	2.84	1214.059	0.46775
2.85	1206.414	0.469438	2.85	1217.985	0.469438
2.86	1210.07	0.471104	2.86	1221.8	0.471104
2.87	1213.582	0.472771	2.87	1225.742	0.472771
2.88	1217.969	0.474438	2.88	1230.192	0.474438
2.89	1222.881	0.476104	2.89	1234.404	0.476104
2.90	1227.649	0.477771	2.90	1238.06	0.477771
2.91	1232.147	0.479396	2.91	1242.717	0.479438
2.92	1236.407	0.481083	2.92	1247.597	0.481083
2.93	1240.508	0.48275	2.93	1252.095	0.48275
2.94	1244.799	0.484417	2.94	1255.989	0.484417
2.95	1250.219	0.486083	2.95	1259.708	0.486083
2.96	1254.829	0.487771	2.96	1263.523	0.487771
2.97	1258.182	0.489458	2.97	1266.94	0.489458
2.98	1261.807	0.491146	2.98	1271.423	0.491146
2.99	1265.446	0.492833	2.99	1276.684	0.492833
3.00	1269.817	0.494521	3.00	1281.039	0.494521

2%wt.			3%wt.		
Time	Force	Stroke	Time	Force	Stroke
sec	N	mm	sec	N	mm
0	-8.02676	0	0	-5.07037	0
0.01	-8.02676	4.17E-05	0.01	-5.07037	6.25E-05
0.02	-8.02676	0.000438	0.02	-5.07037	0.000438
0.03	-8.02676	0.00125	0.03	-5.10216	0.00125
0.04	-8.02676	0.002354	0.04	-5.10216	0.002333
0.05	-8.04265	0.003604	0.05	-5.10216	0.003604
0.06	-8.05855	0.004938	0.06	-5.10216	0.004917
0.07	-8.05855	0.006313	0.07	-5.10216	0.006292
0.08	-8.05855	0.007771	0.08	-5.10216	0.00775
0.09	-8.05855	0.009313	0.09	-5.10216	0.009313
0.1	-8.05855	0.010958	0.1	-5.10216	0.010979
0.11	-8.05855	0.012625	0.11	-5.10216	0.012646
0.12	-8.05855	0.014313	0.12	-5.10216	0.014333
0.13	-8.05855	0.016	0.13	-5.10216	0.016021
0.14	8.805593	0.017688	0.14	11.04673	0.017688
0.15	16.21246	0.019354	0.15	17.5635	0.019375
0.16	21.21925	0.021021	0.16	23.38091	0.021042
0.17	27.03667	0.022708	0.17	29.34138	0.022708
0.18	33.04482	0.024375	0.18	34.28459	0.024375
0.19	39.02118	0.026042	0.19	38.92581	0.026042
0.2	44.17102	0.027729	0.2	43.98028	0.027708
0.21	48.82813	0.029417	0.21	48.22413	0.029396
0.22	53.46934	0.031104	0.22	52.73819	0.031104
0.23	58.88939	0.032813	0.23	57.22046	0.032813
0.24	64.57964	0.0345	0.24	62.0683	0.0345
0.25	69.31623	0.036188	0.25	67.10688	0.036188
0.26	74.75217	0.037854	0.26	72.54282	0.037854
0.27	79.9338	0.0395	0.27	77.35888	0.0395
0.28	85.30617	0.041146	0.28	82.2703	0.041167
0.29	89.8997	0.042813	0.29	87.08636	0.042813
0.3	94.74754	0.044458	0.3	91.06001	0.044458
0.31	100.6285	0.046104	0.31	96.22574	0.046104
0.32	104.6816	0.047771	0.32	101.1213	0.047771
0.33	109.3864	0.049417	0.33	105.5559	0.049417
0.34	113.7098	0.051083	0.34	109.9904	0.051083
0.35	118.7007	0.052771	0.35	114.9336	0.052771
0.36	122.7379	0.054438	0.36	119.6226	0.054438
0.37	127.1566	0.056125	0.37	123.5644	0.056125
0.38	131.8137	0.057792	0.38	127.9513	0.057792
0.39	136.9953	0.059458	0.39	133.2283	0.059438
0.4	141.7001	0.061104	0.4	138.2987	0.061104
0.41	146.7387	0.062771	0.41	142.2087	0.06275
0.42	152.3813	0.064417	0.42	146.7228	0.064417
0.43	156.1483	0.066083	0.43	151.062	0.066083
0.44	160.567	0.06775	0.44	155.4012	0.06775

This material is reserved for educational use only, not allowed for commercial use.

Forbidden to modify the content, and cite the document when use

0.45	164.2386	0.069417	0.45	159.8835	0.069417
0.46	168.8004	0.071104	0.46	163.6187	0.071104
0.47	173.4893	0.072813	0.47	167.497	0.072813
0.48	177.7013	0.0745	0.48	171.7726	0.0745
0.49	181.8498	0.076188	0.49	175.635	0.076188
0.5	187.6831	0.077875	0.5	180.2603	0.077875
0.51	192.3879	0.079542	0.51	184.1704	0.079542
0.52	197.1245	0.081188	0.52	187.7149	0.081188
0.53	202.0041	0.082833	0.53	192.1972	0.082833
0.54	206.1844	0.084479	0.54	196.6635	0.084479
0.55	210.6349	0.086125	0.55	201.6544	0.086125
0.56	215.1648	0.087771	0.56	205.9142	0.087771
0.57	219.7742	0.089417	0.57	209.7766	0.089417
0.58	224.5585	0.091083	0.58	213.9886	0.091083
0.59	228.548	0.09275	0.59	218.7093	0.09275
0.6	233.0939	0.094417	0.6	223.4777	0.094417
0.61	237.5285	0.096104	0.61	227.1334	0.096104
0.62	242.0902	0.097771	0.62	230.5984	0.097771
0.63	246.5248	0.099438	0.63	235.4622	0.099438
0.64	250.6256	0.101104	0.64	239.2451	0.101104
0.65	255.537	0.102771	0.65	243.4572	0.102771
0.66	260.3213	0.104438	0.66	246.5725	0.104417
0.67	264.8195	0.106083	0.67	251.0071	0.106083
0.68	269.0315	0.10775	0.68	254.7105	0.10775
0.69	272.9575	0.109417	0.69	259.5107	0.109417
0.7	276.8358	0.111083	0.7	264.3267	0.111083
0.71	281.9697	0.112771	0.71	268.3481	0.112771
0.72	286.6268	0.114458	0.72	272.274	0.114458
0.73	290.7753	0.116167	0.73	276.2159	0.116146
0.74	295.6549	0.117833	0.74	280.6982	0.117833
0.75	300.0895	0.119521	0.75	285.0215	0.119521
0.76	304.5241	0.121188	0.76	288.9792	0.121188
0.77	310.0554	0.122833	0.77	293.3979	0.122833
0.78	313.9973	0.124479	0.78	297.1808	0.124479
0.79	318.0663	0.126146	0.79	301.2021	0.126146
0.8	322.3578	0.127792	0.8	305.4778	0.127792
0.81	326.8878	0.129438	0.81	309.1494	0.129438
0.82	331.6561	0.131104	0.82	313.584	0.131104
0.83	335.6934	0.132771	0.83	317.7325	0.132771
0.84	339.7465	0.134438	0.84	321.5631	0.134438
0.85	343.5771	0.136104	0.85	325.5844	0.136104
0.86	347.4077	0.137792	0.86	329.4945	0.137792
0.87	351.2224	0.139458	0.87	333.2297	0.139458
0.88	355.6093	0.141125	0.88	337.712	0.141125
0.89	359.6147	0.142792	0.89	342.3691	0.142792
0.9	363.7314	0.144438	0.9	346.0407	0.144438
0.91	368.4839	0.146083	0.91	350.4594	0.146083
0.92	373.1728	0.14775	0.92	354.1946	0.14775

This material is reserved for educational use only, not allowed for commercial use.

Forbidden to modify the content, and cite the document when use

0.93	377.1464	0.149396	0.93	358.3431	0.149396
0.94	381.0565	0.151063	0.94	361.9035	0.151063
0.95	384.7758	0.152729	0.95	367.0215	0.152729
0.96	389.3375	0.154417	0.96	371.1224	0.154417
0.97	392.6436	0.156104	0.97	374.3172	0.156104
0.98	397.3484	0.157813	0.98	378.3385	0.157813
0.99	401.5128	0.1595	0.99	383.0274	0.1595
1	405.5341	0.161167	1	385.9997	0.161167
1.01	409.6031	0.162833	1.01	389.3375	0.162833
1.02	414.0377	0.1645	1.02	394.2808	0.1645
1.03	419.6803	0.166146	1.03	399.0491	0.166146
1.04	424.2738	0.167813	1.04	402.5777	0.167813
1.05	427.5163	0.169458	1.05	406.4242	0.169458
1.06	431.188	0.171104	1.06	410.1435	0.171104
1.07	434.955	0.17275	1.07	413.5609	0.17275
1.08	439.1352	0.174417	1.08	416.4855	0.174417
1.09	443.0612	0.176083	1.09	420.6657	0.176083
1.1	447.0825	0.177771	1.1	425.0367	0.177771
1.11	450.8813	0.179458	1.11	428.9945	0.179438
1.12	455.3795	0.181125	1.12	433.8423	0.181125
1.13	459.4326	0.182792	1.13	437.6888	0.182792
1.14	463.6765	0.184458	1.14	440.5657	0.184458
1.15	467.9998	0.186104	1.15	444.4758	0.186104
1.16	471.9257	0.187771	1.16	449.1329	0.187771
1.17	476.1219	0.189417	1.17	452.9635	0.189417
1.18	480.6678	0.191083	1.18	456.2537	0.191083
1.19	485.15	0.19275	1.19	459.7187	0.19275
1.2	488.9011	0.194438	1.2	464.1533	0.194438
1.21	492.6205	0.196104	1.21	467.5388	0.196104
1.22	497.6591	0.197813	1.22	471.9416	0.197813
1.23	501.442	0.1995	1.23	476.0583	0.1995
1.24	505.3997	0.201188	1.24	479.3008	0.201188
1.25	509.4369	0.202854	1.25	482.9725	0.202854
1.26	513.5854	0.204521	1.26	486.9938	0.204521
1.27	517.6703	0.206167	1.27	491.3012	0.206167
1.28	521.9937	0.207813	1.28	495.3066	0.207813
1.29	525.7448	0.209458	1.29	499.169	0.209458
1.3	529.8774	0.211104	1.3	503.2857	0.211104
1.31	534.9954	0.21275	1.31	508.1336	0.21275
1.32	538.3651	0.214417	1.32	510.8833	0.214417
1.33	542.0367	0.216063	1.33	515.1908	0.216083
1.34	545.8355	0.217729	1.34	519.1803	0.21775
1.35	550.2383	0.219417	1.35	522.9155	0.219417
1.36	554.4186	0.221104	1.36	526.4918	0.221104
1.37	558.7578	0.222771	1.37	530.0363	0.222771
1.38	563.2877	0.224438	1.38	534.4709	0.224438
1.39	566.9753	0.226104	1.39	538.1584	0.226104
1.4	570.6946	0.227771	1.4	542.6566	0.227771

This material is reserved for educational use only, not allowed for commercial use.

Forbidden to modify the content, and cite the document when use

1.41	575.3199	0.229417	1.41	546.5667	0.229417
1.42	579.8499	0.231083	1.42	549.6502	0.231083
1.43	584.6342	0.23275	1.43	553.91	0.23275
1.44	588.878	0.234417	1.44	557.3432	0.234417
1.45	592.6768	0.236083	1.45	560.9512	0.236083
1.46	596.9683	0.237771	1.46	564.7819	0.237771
1.47	601.0532	0.239458	1.47	569.4707	0.239458
1.48	604.8203	0.241167	1.48	574.0007	0.241167
1.49	608.921	0.242854	1.49	577.577	0.242833
1.5	613.3397	0.244521	1.5	580.581	0.244521
1.51	618.124	0.246188	1.51	585.254	0.246188
1.52	622.6857	0.247833	1.52	589.2754	0.247854
1.53	626.0395	0.2495	1.53	593.3921	0.2495
1.54	629.4886	0.251146	1.54	596.9842	0.251146
1.55	634.1934	0.252792	1.55	600.7354	0.252792
1.56	639.0889	0.254458	1.56	605.5355	0.254458
1.57	643.8891	0.256104	1.57	609.382	0.256104
1.58	647.3701	0.257771	1.58	612.4496	0.257771
1.59	651.8523	0.259438	1.59	616.6617	0.259438
1.6	656.3663	0.261125	1.6	621.2234	0.261104
1.61	661.087	0.262792	1.61	625.658	0.262792
1.62	665.4899	0.264479	1.62	629.3456	0.264458
1.63	669.1615	0.266125	1.63	632.7629	0.266125
1.64	672.9444	0.267792	1.64	636.9432	0.267771
1.65	676.8068	0.269438	1.65	641.5367	0.269438
1.66	681.8931	0.271083	1.66	645.7964	0.271083
1.67	686.4548	0.27275	1.67	648.7529	0.27275
1.68	690.9847	0.274396	1.68	653.251	0.274417
1.69	695.1332	0.276063	1.69	656.3505	0.276063
1.7	699.0909	0.277729	1.7	661.103	0.277729
1.71	703.4302	0.279417	1.71	665.8872	0.279417
1.72	707.7853	0.281125	1.72	669.0184	0.281104
1.73	712.808	0.282813	1.73	673.1828	0.282813
1.74	716.7339	0.2845	1.74	676.9657	0.2845
1.75	721.1685	0.286188	1.75	681.146	0.286167
1.76	725.2375	0.287854	1.76	685.2944	0.287833
1.77	729.2906	0.2895	1.77	689.141	0.2895
1.78	734.1862	0.291167	1.78	692.9716	0.291146
1.79	739.1612	0.292813	1.79	696.8021	0.292813
1.8	743.3892	0.294458	1.8	699.8857	0.294458
1.81	747.1721	0.296104	1.81	704.3998	0.296104
1.82	751.0821	0.297771	1.82	708.8026	0.297771
1.83	755.5803	0.299417	1.83	713.7617	0.299417
1.84	759.7446	0.301083	1.84	717.7989	0.301083
1.85	763.3369	0.302771	1.85	721.4864	0.302771
1.86	767.4535	0.304438	1.86	724.9832	0.304438
1.87	771.7927	0.306125	1.87	728.2575	0.306125
1.88	776.4498	0.307792	1.88	731.802	0.307792

This material is reserved for educational use only, not allowed for commercial use.

Forbidden to modify the content, and cite the document when use

1.89	780.7414	0.309458	1.89	736.7134	0.309438
1.9	785.3508	0.311104	1.9	739.9559	0.311104
1.91	789.0861	0.312771	1.91	744.0885	0.312771
1.92	793.155	0.314417	1.92	748.4277	0.314417
1.93	798.5274	0.316083	1.93	752.7192	0.316083
1.94	802.4534	0.31775	1.94	756.1207	0.31775
1.95	806.6177	0.319438	1.95	760.0625	0.319438
1.96	810.6868	0.321125	1.96	764.7197	0.321125
1.97	814.9783	0.322813	1.97	768.1688	0.322813
1.98	819.1268	0.324521	1.98	771.7609	0.324521
1.99	823.2911	0.326188	1.99	775.4485	0.326208
2	827.2807	0.327875	2	780.0897	0.327875
2.01	831.906	0.329542	2.01	784.9534	0.329542
2.02	836.7379	0.331188	2.02	788.2754	0.331188
2.03	840.6003	0.332833	2.03	791.4066	0.332833
2.04	845.2574	0.334479	2.04	795.5869	0.334479
2.05	848.9132	0.336125	2.05	799.64	0.336125
2.06	853.1411	0.337771	2.06	803.8044	0.337771
2.07	857.1307	0.339417	2.07	807.5555	0.339417
2.08	861.2315	0.341083	2.08	810.941	0.341083
2.09	865.8409	0.34275	2.09	815.5663	0.34275
2.1	870.2437	0.344417	2.1	820.0328	0.344417
2.11	874.265	0.346104	2.11	823.4183	0.346104
2.12	878.3976	0.347771	2.12	826.8038	0.347771
2.13	883.325	0.349438	2.13	830.9523	0.349438
2.14	887.696	0.351104	2.14	834.5604	0.351104
2.15	891.0179	0.352771	2.15	837.9777	0.352771
2.16	895.0869	0.354438	2.16	842.1262	0.354417
2.17	899.4579	0.356083	2.17	845.8137	0.356083
2.18	903.8607	0.35775	2.18	850.3437	0.35775
2.19	908.3112	0.359417	2.19	854.9213	0.359417
2.2	913.0955	0.361083	2.2	859.038	0.361083
2.21	916.942	0.362771	2.21	862.1375	0.362771
2.22	920.407	0.364458	2.22	865.4595	0.364479
2.23	925.4138	0.366146	2.23	870.1484	0.366167
2.24	929.3874	0.367833	2.24	873.0889	0.367854
2.25	933.4564	0.369521	2.25	877.1102	0.369521
2.26	938.2407	0.371188	2.26	881.4494	0.371188
2.27	941.8964	0.372833	2.27	885.566	0.372833
2.28	945.7747	0.374479	2.28	889.0947	0.374479
2.29	950.6226	0.376146	2.29	893.1478	0.376146
2.3	955.1207	0.377792	2.3	897.2486	0.377792
2.31	958.3791	0.379438	2.31	901.1586	0.379458
2.32	962.9567	0.381104	2.32	905.7522	0.381104
2.33	966.7396	0.382771	2.33	908.8516	0.382771
2.34	970.8087	0.384438	2.34	911.4901	0.384438
2.35	974.7188	0.386104	2.35	915.4797	0.386104
2.36	978.7401	0.387792	2.36	919.803	0.387792

This material is reserved for educational use only, not allowed for commercial use.

Forbidden to modify the content, and cite the document when use

2.37	983.429	0.389458	2.37	923.3634	0.389458
2.38	988.1973	0.391125	2.38	927.337	0.391125
2.39	992.0597	0.392792	2.39	930.9292	0.392792
2.4	996.5579	0.394438	2.4	936.0472	0.394438
2.41	1001.247	0.396083	2.41	940.1798	0.396083
2.42	1004.775	0.39775	2.42	943.8832	0.39775
2.43	1009.242	0.399417	2.43	947.5549	0.399396
2.44	1012.913	0.401063	2.44	950.9881	0.401063
2.45	1016.808	0.402729	2.45	954.2306	0.402729
2.46	1021.846	0.404417	2.46	958.9672	0.404417
2.47	1026.233	0.406125	2.47	962.7183	0.406125
2.48	1029.698	0.407813	2.48	966.5172	0.407813
2.49	1034.435	0.4095	2.49	970.459	0.4095
2.5	1038.837	0.411188	2.5	973.9717	0.411188
2.51	1042.048	0.412854	2.51	978.1202	0.412854
2.52	1046.53	0.4145	2.52	982.1733	0.414521
2.53	1050.488	0.416167	2.53	986.1628	0.416167
2.54	1054.923	0.417813	2.54	989.9616	0.417813
2.55	1059.484	0.419479	2.55	993.6174	0.419479
2.56	1063.474	0.421125	2.56	997.4162	0.421125
2.57	1068.211	0.422792	2.57	1000.722	0.422771
2.58	1071.898	0.424438	2.58	1004.028	0.424438
2.59	1076.523	0.426104	2.59	1007.477	0.426104
2.6	1080.91	0.427771	2.6	1011.896	0.427771
2.61	1084.121	0.429458	2.61	1015.949	0.429458
2.62	1087.221	0.431125	2.62	1019.239	0.431125
2.63	1092.084	0.432792	2.63	1023.436	0.432792
2.64	1096.392	0.434438	2.64	1027.346	0.434458
2.65	1099.348	0.436104	2.65	1031.113	0.436104
2.66	1103.767	0.43775	2.66	1035.277	0.43775
2.67	1108.106	0.439417	2.67	1038.837	0.439417
2.68	1112.986	0.441083	2.68	1042.175	0.441083
2.69	1116.403	0.44275	2.69	1046.197	0.44275
2.7	1120.504	0.444438	2.7	1049.932	0.444438
2.71	1124.62	0.446104	2.71	1053.794	0.446104
2.72	1128.801	0.447813	2.72	1057.72	0.447813
2.73	1133.029	0.4495	2.73	1060.963	0.4495
2.74	1137.304	0.451188	2.74	1064.889	0.451188
2.75	1141.246	0.452854	2.75	1069.276	0.452875
2.76	1145.252	0.454521	2.76	1073.011	0.454521
2.77	1149.575	0.456167	2.77	1076.667	0.456167
2.78	1153.708	0.457813	2.78	1080.561	0.457813
2.79	1157.649	0.459479	2.79	1083.994	0.459479
2.8	1161.639	0.461125	2.8	1088.047	0.461125
2.81	1167.043	0.462771	2.81	1091.655	0.462771
2.82	1170.349	0.464417	2.82	1094.786	0.464417
2.83	1173.798	0.466083	2.83	1099.841	0.466083
2.84	1177.883	0.46775	2.84	1103.544	0.46775

This material is reserved for educational use only, not allowed for commercial use.

Forbidden to modify the content, and cite the document when use

2.85	1181.873	0.469438	2.85	1106.294	0.469417
2.86	1186.482	0.471104	2.86	1110.013	0.471104
2.87	1191.998	0.472771	2.87	1113.447	0.472771
2.88	1195.955	0.474438	2.88	1117.802	0.474438
2.89	1199.373	0.476104	2.89	1122.03	0.476104
2.9	1202.091	0.477771	2.9	1125.177	0.477771
2.91	1207.32	0.479417	2.91	1129.818	0.479438
2.92	1211.468	0.481083	2.92	1133.982	0.481083
2.93	1215.458	0.48275	2.93	1136.589	0.48275
2.94	1218.43	0.484417	2.94	1139.084	0.484417
2.95	1222.213	0.486083	2.95	1143.106	0.486083
2.96	1226.648	0.487771	2.96	1148.192	0.487771
2.97	1231.241	0.489458	2.97	1152.054	0.489458
2.98	1235.326	0.491167	2.98	1154.709	0.491167
2.99	1239.173	0.492833	2.99	1158.412	0.492833
3	1242.924	0.494521	3	1163.085	0.494521

4%wt.			5%wt.		
Time	Force	Stroke	Time	Force	Stroke
sec	N	mm	sec	N	mm
0	-6.85056	0	0	-8.15392	0
0.01	-6.85056	6.25E-05	0.01	-8.15392	6.25E-05
0.02	-6.85056	0.000438	0.02	-8.1857	0.000417
0.03	-6.85056	0.00125	0.03	-8.1857	0.00125
0.04	-6.85056	0.002354	0.04	-8.1857	0.002333
0.05	-6.85056	0.003604	0.05	-8.1857	0.003604
0.06	-6.85056	0.004938	0.06	-8.1857	0.004938
0.07	-6.86646	0.006354	0.07	-8.1857	0.006292
0.08	-6.88235	0.007792	0.08	-8.1857	0.00775
0.09	-6.88235	0.009333	0.09	-8.23339	0.009313
0.1	-6.88235	0.010979	0.1	-8.23339	0.010958
0.11	-6.88235	0.012646	0.11	-8.23339	0.012625
0.12	-6.88235	0.014333	0.12	-8.23339	0.014313
0.13	-6.88235	0.016021	0.13	-8.23339	0.016
0.14	10.20432	0.017688	0.14	12.07987	0.017688
0.15	18.11981	0.019354	0.15	17.2774	0.019354
0.16	24.25512	0.021042	0.16	24.28691	0.021021
0.17	30.34274	0.022708	0.17	30.24737	0.022708
0.18	35.93763	0.024375	0.18	36.62109	0.024375
0.19	42.35904	0.026042	0.19	42.20009	0.026042
0.2	48.3036	0.027729	0.2	48.6056	0.027729
0.21	54.15281	0.029417	0.21	54.64554	0.029396
0.22	59.03244	0.031125	0.22	59.97022	0.031104
0.23	64.92933	0.032813	0.23	66.16911	0.032813
0.24	70.34937	0.0345	0.24	71.39841	0.0345
0.25	76.26215	0.036188	0.25	76.73899	0.036167

This material is reserved for educational use only, not allowed for commercial use.

Forbidden to modify the content, and cite the document when use

0.26	81.96831	0.037854	0.26	82.47694	0.037833
0.27	87.05457	0.0395	0.27	87.22941	0.0395
0.28	91.45737	0.041167	0.28	93.38061	0.041167
0.29	96.54363	0.042813	0.29	98.45098	0.042813
0.3	101.5504	0.044458	0.3	103.9028	0.044458
0.31	107.1135	0.046104	0.31	109.1798	0.046104
0.32	112.2634	0.047771	0.32	113.5667	0.047771
0.33	117.286	0.049438	0.33	118.1761	0.049417
0.34	122.261	0.051104	0.34	123.5008	0.051083
0.35	126.8069	0.052771	0.35	128.5871	0.052771
0.36	132.2269	0.054458	0.36	132.8309	0.054438
0.37	137.1702	0.056125	0.37	137.6947	0.056125
0.38	142.018	0.057792	0.38	142.622	0.057792
0.39	147.6288	0.059438	0.39	148.1056	0.059438
0.4	152.3336	0.061104	0.4	153.0965	0.061104
0.41	157.3404	0.062771	0.41	157.4039	0.062771
0.42	162.6968	0.064417	0.42	162.6015	0.064417
0.43	167.5288	0.066083	0.43	167.9103	0.066083
0.44	172.9965	0.06775	0.44	173.5528	0.06775
0.45	176.4297	0.069438	0.45	178.353	0.069438
0.46	181.7703	0.071125	0.46	182.6127	0.071104
0.47	187.3811	0.072833	0.47	187.3811	0.072813
0.48	191.3707	0.074521	0.48	192.1813	0.0745
0.49	196.1867	0.076208	0.49	197.5219	0.076188
0.5	200.812	0.077875	0.5	203.0055	0.077875
0.51	205.6281	0.079542	0.51	206.7089	0.079542
0.52	211.0799	0.081188	0.52	211.827	0.081188
0.53	215.2602	0.082833	0.53	217.5172	0.082833
0.54	221.0299	0.084479	0.54	222.4604	0.084479
0.55	226.5135	0.086125	0.55	227.0381	0.086125
0.56	230.5984	0.087771	0.56	232.1879	0.087771
0.57	235.0013	0.089417	0.57	236.9722	0.089417
0.58	239.4358	0.091083	0.58	242.1379	0.091083
0.59	244.5221	0.09275	0.59	245.7937	0.09275
0.6	249.5925	0.094417	0.6	249.9104	0.094417
0.61	254.7264	0.096104	0.61	254.7423	0.096104
0.62	259.3994	0.097771	0.62	259.8127	0.097771
0.63	263.5002	0.099438	0.63	265.185	0.099438
0.64	268.6978	0.101104	0.64	270.2872	0.101104
0.65	273.1482	0.102771	0.65	274.833	0.102771
0.66	278.4411	0.104438	0.66	278.7431	0.104438
0.67	282.6691	0.106083	0.67	283.6227	0.106104
0.68	287.1354	0.10775	0.68	288.6136	0.10775
0.69	291.7925	0.109417	0.69	293.1913	0.109417
0.7	296.5609	0.111104	0.7	297.6418	0.111083
0.71	301.8538	0.112771	0.71	301.5677	0.112771
0.72	306.3361	0.114479	0.72	306.5109	0.114458
0.73	311.3588	0.116167	0.73	311.8992	0.116146

This material is reserved for educational use only, not allowed for commercial use.

Forbidden to modify the content, and cite the document when use

0.74	315.2529	0.117854	0.74	316.9695	0.117833
0.75	320.8001	0.119521	0.75	322.2466	0.119521
0.76	324.885	0.121188	0.76	326.8719	0.121188
0.77	329.558	0.122833	0.77	331.3859	0.122833
0.78	334.4059	0.1245	0.78	336.1543	0.124479
0.79	339.3173	0.126146	0.79	340.4617	0.126146
0.8	343.7678	0.127792	0.8	344.6102	0.127792
0.81	347.4236	0.129438	0.81	349.2991	0.129438
0.82	351.6992	0.131104	0.82	354.0834	0.131104
0.83	356.6106	0.132771	0.83	359.0902	0.132771
0.84	361.8399	0.134458	0.84	363.5089	0.134438
0.85	365.8136	0.136125	0.85	368.5792	0.136104
0.86	369.2945	0.137792	0.86	372.378	0.137792
0.87	374.7463	0.139458	0.87	376.908	0.139458
0.88	379.3398	0.141125	0.88	381.9943	0.141125
0.89	382.5029	0.142792	0.89	386.6037	0.142771
0.9	386.7944	0.144438	0.9	391.7853	0.144438
0.91	391.7853	0.146083	0.91	395.9497	0.146083
0.92	396.0768	0.14775	0.92	400.4637	0.147729
0.93	400.4001	0.149396	0.93	405.1049	0.149396
0.94	403.9129	0.151063	0.94	410.1753	0.151063
0.95	408.57	0.152729	0.95	414.5463	0.152729
0.96	413.7039	0.154438	0.96	419.4101	0.154417
0.97	418.663	0.156125	0.97	423.8923	0.156104
0.98	422.8433	0.157813	0.98	428.1203	0.157813
0.99	427.7229	0.1595	0.99	432.1575	0.159479
1	431.7919	0.161167	1	436.8782	0.161167
1.01	436.2901	0.162833	1.01	440.9949	0.162833
1.02	440.8995	0.1645	1.02	446.3514	0.1645
1.03	444.6983	0.166146	1.03	451.3741	0.166167
1.04	448.2905	0.167813	1.04	456.0789	0.167813
1.05	452.8522	0.169458	1.05	460.7042	0.169458
1.06	457.5729	0.171104	1.06	465.107	0.171104
1.07	462.0711	0.172771	1.07	469.2554	0.17275
1.08	466.8713	0.174417	1.08	473.5152	0.174417
1.09	471.2264	0.176104	1.09	477.9816	0.176083
1.1	475.2159	0.177771	1.1	483.1473	0.177771
1.11	479.0147	0.179458	1.11	487.0733	0.179458
1.12	484.3553	0.181125	1.12	491.8416	0.181125
1.13	489.4098	0.182792	1.13	495.9742	0.182792
1.14	492.9384	0.184458	1.14	500.3452	0.184438
1.15	496.1332	0.186104	1.15	504.8752	0.186104
1.16	501.3148	0.187771	1.16	509.6436	0.187771
1.17	507.1322	0.189417	1.17	514.4119	0.189417
1.18	512.1708	0.191083	1.18	518.8148	0.191083
1.19	515.8265	0.192771	1.19	523.7739	0.19275
1.2	520.2452	0.194438	1.2	528.7965	0.194438
1.21	525.252	0.196125	1.21	533.5649	0.196125

This material is reserved for educational use only, not allowed for commercial use.

Forbidden to modify the content, and cite the document when use

1.22	529.9091	0.197813	1.22	538.2061	0.197813
1.23	533.9305	0.1995	1.23	542.4976	0.1995
1.24	538.8419	0.201188	1.24	546.8051	0.201188
1.25	543.6262	0.202875	1.25	551.2078	0.202854
1.26	547.5998	0.204521	1.26	556.4213	0.204521
1.27	552.4794	0.206188	1.27	560.9672	0.206167
1.28	556.6756	0.207813	1.28	565.6719	0.207813
1.29	561.6188	0.209479	1.29	570.0588	0.209458
1.3	565.9739	0.211104	1.3	573.9689	0.211104
1.31	569.8522	0.212771	1.31	578.7849	0.21275
1.32	574.9543	0.214417	1.32	583.3149	0.214417
1.33	578.8326	0.216083	1.33	588.0197	0.216063
1.34	583.3308	0.217729	1.34	592.788	0.217729
1.35	587.7018	0.219417	1.35	596.7776	0.219417
1.36	592.6768	0.221104	1.36	600.783	0.221104
1.37	597.5087	0.222771	1.37	605.8693	0.222771
1.38	602.7222	0.224438	1.38	610.7966	0.224438
1.39	606.2985	0.226104	1.39	614.8974	0.226104
1.4	610.8761	0.227771	1.4	618.6008	0.227771
1.41	615.0245	0.229417	1.41	623.5759	0.229417
1.42	619.8406	0.231083	1.42	628.678	0.231083
1.43	624.609	0.23275	1.43	633.8279	0.23275
1.44	628.5668	0.234417	1.44	638.6757	0.234417
1.45	633.2715	0.236104	1.45	642.7924	0.236083
1.46	638.2783	0.237771	1.46	646.6389	0.237771
1.47	641.6161	0.239479	1.47	650.9304	0.239458
1.48	646.4958	0.241167	1.48	655.8577	0.241167
1.49	650.5648	0.242854	1.49	660.0698	0.242854
1.5	655.7147	0.244521	1.5	664.6951	0.244521
1.51	660.5625	0.246188	1.51	669.5112	0.246188
1.52	665.1243	0.247833	1.52	674.2159	0.247854
1.53	669.829	0.2495	1.53	680.0811	0.2495
1.54	673.7073	0.251146	1.54	685.0402	0.251146
1.55	678.2691	0.252813	1.55	688.9184	0.252792
1.56	682.4175	0.254458	1.56	692.6219	0.254458
1.57	687.8058	0.256104	1.57	697.1359	0.256104
1.58	692.3358	0.257771	1.58	702.1586	0.257771
1.59	696.3571	0.259458	1.59	706.625	0.259438
1.6	700.4579	0.261125	1.6	710.4556	0.261104
1.61	705.1627	0.262792	1.61	715.1127	0.262792
1.62	709.6768	0.264458	1.62	720.2466	0.264458
1.63	713.9524	0.266125	1.63	724.6494	0.266125
1.64	719.0864	0.267792	1.64	729.3383	0.267792
1.65	724.2679	0.269438	1.65	733.8683	0.269438
1.66	727.7489	0.271083	1.66	738.3823	0.271083
1.67	731.9927	0.27275	1.67	742.8487	0.27275
1.68	736.4273	0.274396	1.68	746.9813	0.274396
1.69	741.5135	0.276063	1.69	751.8132	0.276063

This material is reserved for educational use only, not allowed for commercial use.

Forbidden to modify the content, and cite the document when use

1.7	744.8832	0.27775	1.7	755.6756	0.277729
1.71	749.2065	0.279438	1.71	760.4281	0.279417
1.72	754.0385	0.281125	1.72	764.4813	0.281125
1.73	758.791	0.282813	1.73	768.9158	0.282813
1.74	763.6865	0.2845	1.74	773.4458	0.2845
1.75	767.8191	0.286188	1.75	778.1664	0.286188
1.76	772.5715	0.287854	1.76	782.9189	0.287854
1.77	777.6737	0.2895	1.77	787.131	0.2895
1.78	781.7586	0.291167	1.78	791.8676	0.291146
1.79	785.5892	0.292813	1.79	796.5088	0.292813
1.8	790.4847	0.294458	1.8	800.4824	0.294458
1.81	794.3948	0.296125	1.81	805.1873	0.296104
1.82	798.5909	0.297771	1.82	810.4324	0.297771
1.83	803.9634	0.299438	1.83	814.7399	0.299417
1.84	808.3184	0.301083	1.84	818.332	0.301083
1.85	812.6259	0.302771	1.85	822.4169	0.302771
1.86	816.2499	0.304438	1.86	827.8052	0.304438
1.87	820.8275	0.306125	1.87	831.8424	0.306125
1.88	825.6436	0.307792	1.88	836.1022	0.307792
1.89	829.8715	0.309438	1.89	840.4731	0.309438
1.9	834.322	0.311104	1.9	846.0045	0.311104
1.91	839.3287	0.312771	1.91	850.4708	0.312771
1.92	843.7316	0.314438	1.92	854.6511	0.314417
1.93	847.5463	0.316083	1.93	858.8314	0.316083
1.94	851.7106	0.317771	1.94	862.9322	0.31775
1.95	856.3995	0.319438	1.95	867.3827	0.319438
1.96	859.9758	0.321125	1.96	871.563	0.321125
1.97	864.8237	0.322833	1.97	876.379	0.322813
1.98	869.1311	0.324521	1.98	880.7659	0.324521
1.99	873.8835	0.326208	1.99	885.2164	0.326208
2	878.7155	0.327875	2	890.0325	0.327875
2.01	882.9594	0.329542	2.01	894.5942	0.329542
2.02	887.2986	0.331188	2.02	898.4089	0.331188
2.03	891.7491	0.332833	2.03	902.7163	0.332833
2.04	895.8817	0.334479	2.04	907.3734	0.334479
2.05	901.1268	0.336125	2.05	911.6808	0.336125
2.06	905.6727	0.337771	2.06	916.6082	0.337771
2.07	910.4888	0.339417	2.07	920.709	0.339417
2.08	914.1604	0.341083	2.08	925.4932	0.341083
2.09	918.2136	0.34275	2.09	930.0232	0.34275
2.1	922.3143	0.344438	2.1	934.4101	0.344417
2.11	926.2085	0.346104	2.11	938.7017	0.346104
2.12	930.9451	0.347771	2.12	943.327	0.347771
2.13	935.3638	0.349438	2.13	947.5231	0.349438
2.14	939.4963	0.351104	2.14	951.91	0.351104
2.15	943.025	0.352771	2.15	956.8055	0.352771
2.16	947.6503	0.354438	2.16	961.8759	0.354417
2.17	952.2756	0.356104	2.17	965.3886	0.356083

This material is reserved for educational use only, not allowed for commercial use.

Forbidden to modify the content, and cite the document when use

2.18	957.1075	0.35775	2.18	969.3782	0.35775
2.19	960.9699	0.359417	2.19	973.8763	0.359417
2.2	965.1979	0.361083	2.2	978.3904	0.361083
2.21	969.1874	0.362771	2.21	983.127	0.362771
2.22	973.6061	0.364479	2.22	987.0529	0.364458
2.23	978.1202	0.366167	2.23	991.6942	0.366167
2.24	983.1906	0.367854	2.24	996.2241	0.367854
2.25	988.2609	0.369521	2.25	1000.277	0.369521
2.26	991.5034	0.371188	2.26	1004.203	0.371188
2.27	995.6042	0.372833	2.27	1008.59	0.372833
2.28	1000.42	0.3745	2.28	1013.565	0.374479
2.29	1004.998	0.376146	2.29	1017.809	0.376146
2.3	1009.067	0.377792	2.3	1022.228	0.377792
2.31	1013.502	0.379458	2.31	1026.726	0.379458
2.32	1017.586	0.381104	2.32	1031.431	0.381104
2.33	1021.878	0.382771	2.33	1035.198	0.382771
2.34	1026.185	0.384438	2.34	1040.141	0.384438
2.35	1030.477	0.386125	2.35	1043.749	0.386104
2.36	1035.5	0.387792	2.36	1048.215	0.387792
2.37	1038.949	0.389458	2.37	1052.459	0.389458
2.38	1043.24	0.391125	2.38	1057.084	0.391125
2.39	1047.611	0.392792	2.39	1062.218	0.392792
2.4	1051.569	0.394438	2.4	1066.987	0.394438
2.41	1056.353	0.396104	2.41	1070.213	0.396083
2.42	1060.613	0.39775	2.42	1074.664	0.39775
2.43	1064.666	0.399417	2.43	1079.273	0.399396
2.44	1068.735	0.401063	2.44	1083.008	0.401063
2.45	1073.122	0.40275	2.45	1086.95	0.402729
2.46	1077.223	0.404438	2.46	1091.448	0.404417
2.47	1081.737	0.406125	2.47	1096.376	0.406125
2.48	1086.06	0.407833	2.48	1100.127	0.407813
2.49	1090.527	0.4095	2.49	1104.101	0.4095
2.5	1094.564	0.411188	2.5	1108.265	0.411188
2.51	1098.41	0.412854	2.51	1113.621	0.412854
2.52	1102.893	0.414521	2.52	1118.263	0.414521
2.53	1107.868	0.416167	2.53	1121.728	0.416167
2.54	1111.921	0.417833	2.54	1125.971	0.417813
2.55	1115.767	0.419479	2.55	1129.738	0.419479
2.56	1119.534	0.421125	2.56	1134.3	0.421125
2.57	1124.859	0.422771	2.57	1138.782	0.422792
2.58	1128.531	0.424438	2.58	1142.613	0.424438
2.59	1132.234	0.426104	2.59	1146.825	0.426104
2.6	1136.128	0.427792	2.6	1151.339	0.427771
2.61	1141.357	0.429458	2.61	1155.615	0.429458
2.62	1145.585	0.431125	2.62	1159.954	0.431125
2.63	1149.13	0.432792	2.63	1164.277	0.432792
2.64	1154.2	0.434438	2.64	1168.331	0.434458
2.65	1159.207	0.436104	2.65	1172.304	0.436104

This material is reserved for educational use only, not allowed for commercial use.

Forbidden to modify the content, and cite the document when use

2.66	1162.147	0.43775	2.66	1176.882	0.43775
2.67	1165.978	0.439438	2.67	1181.301	0.439417
2.68	1170.349	0.441083	2.68	1185.115	0.441083
2.69	1174.656	0.44275	2.69	1188.93	0.44275
2.7	1179.218	0.444438	2.7	1192.999	0.444438
2.71	1183.383	0.446125	2.71	1197.72	0.446125
2.72	1187.452	0.447833	2.72	1201.296	0.447813
2.73	1192.045	0.449521	2.73	1205.333	0.4495
2.74	1195.415	0.451208	2.74	1209.513	0.451188
2.75	1199.023	0.452875	2.75	1213.805	0.452854
2.76	1203.632	0.454521	2.76	1218.653	0.454521
2.77	1207.733	0.456188	2.77	1223.66	0.456167
2.78	1211.786	0.457833	2.78	1228.301	0.457813
2.79	1215.903	0.459479	2.79	1231.591	0.459458
2.8	1220.194	0.461125	2.8	1235.549	0.461125
2.81	1224.057	0.462771	2.81	1239.761	0.462771
2.82	1228.015	0.464417	2.82	1244.513	0.464417
2.83	1232.147	0.466083	2.83	1248.805	0.466083
2.84	1236.566	0.46775	2.84	1252.762	0.46775
2.85	1240.746	0.469417	2.85	1256.752	0.469417
2.86	1245.149	0.471104	2.86	1260.678	0.471104
2.87	1248.741	0.472771	2.87	1265.097	0.472771
2.88	1252.333	0.474438	2.88	1269.436	0.474438
2.89	1257.324	0.476104	2.89	1274.284	0.476104
2.9	1261.52	0.477771	2.9	1277.272	0.477771
2.91	1265.081	0.479438	2.91	1280.943	0.479417
2.92	1268.991	0.481104	2.92	1285.251	0.481083
2.93	1273.394	0.48275	2.93	1290.735	0.48275
2.94	1276.668	0.484438	2.94	1295.042	0.484417
2.95	1281.595	0.486104	2.95	1298.952	0.486083
2.96	1285.982	0.487771	2.96	1302.671	0.487771
2.97	1289.956	0.489479	2.97	1306.2	0.489458
2.98	1294.184	0.491167	2.98	1311.255	0.491146
2.99	1299.095	0.492854	2.99	1315.133	0.492833
3	1302.465	0.494521	3	1319.52	0.494521

BIBLIOGRAPHY

- Name:** Tanakorn Patcharapisutsin
- Date of Birth:** 25/07/1997
- Address:** 247/16, Alley 11, Thajarearn village, Sutthihanna R., Hadyai, Songkhla, Thailand, 90110
- E-mail:** 58010539@kmitl.ac.th, tanakorn.gone@gmail.com
- Academic Background:** Bachelor degree of Petrochemical Engineering
- Working Experience:** Internship with PTTGC.