

**PERFORMANCE INVESTIGATION OF VISIBLE LIGHT COMMUNICATION
NETWORK**



**A THESIS SUBMITTED IN PARTIAL FULFILLMENT
OF THE REQUIREMENTS FOR THE DEGREE OF
MASTER OF ENGINEERING IN COMPUTING IN ENGINEERING SYSTEMS
INTERNATIONAL COLLEGE
KING MONGKUT'S INSTITUTE OF TECHNOLOGY LADKRABANG**

2016

KMITL-2016-IC-M-011-04

This material is reserved for educational use only, not allowed for commercial use.

Forbidden to modify the content, and cite the document when use.



COPYRIGHT 2016

INTERNATIONAL COLLEGE

KING MONGKUT'S INSTITUTE OF TECHNOLOGY LADKRABANG

This material is reserved for educational use only, not allowed for commercial use.

Forbidden to modify the content, and cite the document when use.

Thesis Title	Performance Investigation of Visible Light Communication Network
Student	Yakub Fahim Luckyarno
Student ID	58610017
Degree	Master of Engineering
Program	Computing In Engineering Systems
Thesis Advisor	Asst. Prof. Dr. Chaiwat Nuthong
Thesis Co-advisor	Asst. Prof. Dr. Panarat Cherntanomwong

ABSTRACT

A visible light communication (VLC) is an optical wireless communication technology that is developed rapidly in recent years, besides radio-frequency-based wireless communication. The most common application of it is for indoor communication. Many researchers already conducted researches in various fields of this technology but only a few researchers conducted researches based on the standard. Some of them conducted simulation-based but not hardware-based researches. This research proposes a VLC system based on the IEEE 802.15.7 standard PHY I. It consists of a pair of transceivers. The transceiver consists of the LED with the lens as the transmitter and an SFH203P, high-speed photodiode, as the receiver. This research aims to investigate the performance of the system using PHY I by testing it using some parameters, which are throughput, distance, bit error rate (BER), and types of files. Based on the performance tests, the VLC system can send data at the data rate of 100 kbps. The maximum distance reached for successful data transmission without any missing bit is 40 cm. The lowest bit error rate happens when the system sends a byte sequence containing numbers from 2^1 to 2^{30} and the highest bit error rate happens when the system sends a byte sequence containing number only 2^1 . The bit error is starting to occur at the distance of 50 cm. The system cannot send PNG image and it has 30% probability of successful transmission for the GIF image. In the document file, such as an Excel file, PDF file, PowerPoint file, and Word file, the highest probability of successful transmission is PDF file, which is 70% and the lowest probability of successful transmission is the Excel file, which is 20%. The system can send the Text file with the probability of 100% for a successful transmission

ACKNOWLEDGEMENTS

First, I would like to say thank to Allah SWT, the Almighty God, that with His blesses, I can stand at this point. Also, I would like to say thank to my mom and dad, who always put my name in their prayer and also support me, so that I can finish my study and this project.

It is a great honor to be supervised by Asst. Prof. Dr. Panarat Cherntanomwong under the Wireless Information Network Laboratory, Department of Computer Engineering, Faculty of Engineering, King Mongkut's Institute of Technology Ladkrabang. She always encourage me by giving me the freedom to explore everything about the research, in order to gain my knowledge and increase my skill in the research. Also, with her expertise in the research area, I can get many knowledge from a discussion with her. Thank you to my Master degree lab mates (P' Krit, P' Pon, and Nok), who always help me every time and share together about the research. Also thank you to Bachelor degree lab mates (Tong, First, and Boom), who always help me when I need to order something and share together about useful information in Thailand.

I would to say thank to all lecturers and staffs in International College, King Mongkut's Institute of Technology Ladkrabang for their support and care. Thank you to the all lecturers in the class where I already enrolled who already give the best experience to me in the class, not only about the course but also the value behind the course.

Third, I say thank to AUN/SEED-Net that already gives this opportunity through scholarship so that I can pursue my higher degree education. Thank you to Mr. Krit Manator who always take care of us during our study at King Mongkut's Institute of Technology Ladkrabang and gives us useful informations about the scholarship.

Last but not least, I would to say thank you to all of my friends (International and Thai) for having me a support and care during my stay here in Bangkok. Thank you for giving me the wonderful experience about living in Bangkok and give another insight about Thailand.

Bangkok, July 2017

Yakub Fahim Luckyarno

TABLE OF CONTENTS

	Page
ABSTRACT	
ACKNOWLEDGEMENTS	i
TABLE OF CONTENTS	ii
LIST OF FIGURES	v
LIST OF TABLES	xi
LIST OF ABBREVIATIONS	xii
CHAPTER	
1 INTRODUCTION	1
1.1 Introduction	1
1.2 Objective of the Research	1
1.3 Methodology	2
1.4 Thesis Organization	2
2 LITERATURE REVIEW	3
2.1 Visible Light Communication	3
2.2 VLC Standard: IEEE 802.15.7	4
2.3 Baseband Modulation	7
2.4 Universal Asynchronous Receiver/Transmitter (UART)	10
2.5 Microcontroller	10
2.5.1 Arduino Mega 2560 R3	10
2.6 VLC Transmitter	11
2.6.1 Visible Light	11
2.6.2 Light Emitting Diode (LED)	11
2.7 VLC Receiver	12
2.7.1 Photodiode	12
3 VLC SYSTEM AND EXPERIMENTAL SETUP	16

This material is reserved for educational use only, not allowed for commercial use.

Forbidden to modify the content, and cite the document when use.

3.1	Transceiver	16
3.2	Experimental Setup	17
3.2.1	Throughput	19
3.2.2	Bit Error Rate	21
3.2.3	Distance	23
3.2.4	Types of file	23
3.2.4.1	Document file	24
3.2.4.2	Image file	24
3.2.4.3	Audio file	24
4	RESULTS AND DISCUSSIONS	25
4.1	Transceiver	25
4.2	Throughput	25
4.3	BER	25
4.4	Distance	32
4.5	Types of file	34
4.5.1	Audio file	35
4.5.2	Image file	36
4.5.3	Document file	37
4.5.3.1	Excel file	37
4.5.3.2	Word file	38
4.5.3.3	PDF file	38
4.5.3.4	Powerpoint file	39
4.5.3.5	Text file	40
5	CONCLUSION AND FUTURE WORKS	42
	REFERENCES	43
	APPENDICES	48
	APPENDIX A Audio File Results	48

This material is reserved for educational use only, not allowed for commercial use.

CHAPTER	Page
APPENDIX B Image File Results	50
APPENDIX C Document File Results	57
C.1 Excel File Results	57
C.2 Word File Results	62
C.3 PDF File Results	68
C.4 PowerPoint File Results	73
C.5 Text File Results	80
BIOGRAPHY	83
LIST OF PUBLICATIONS	84

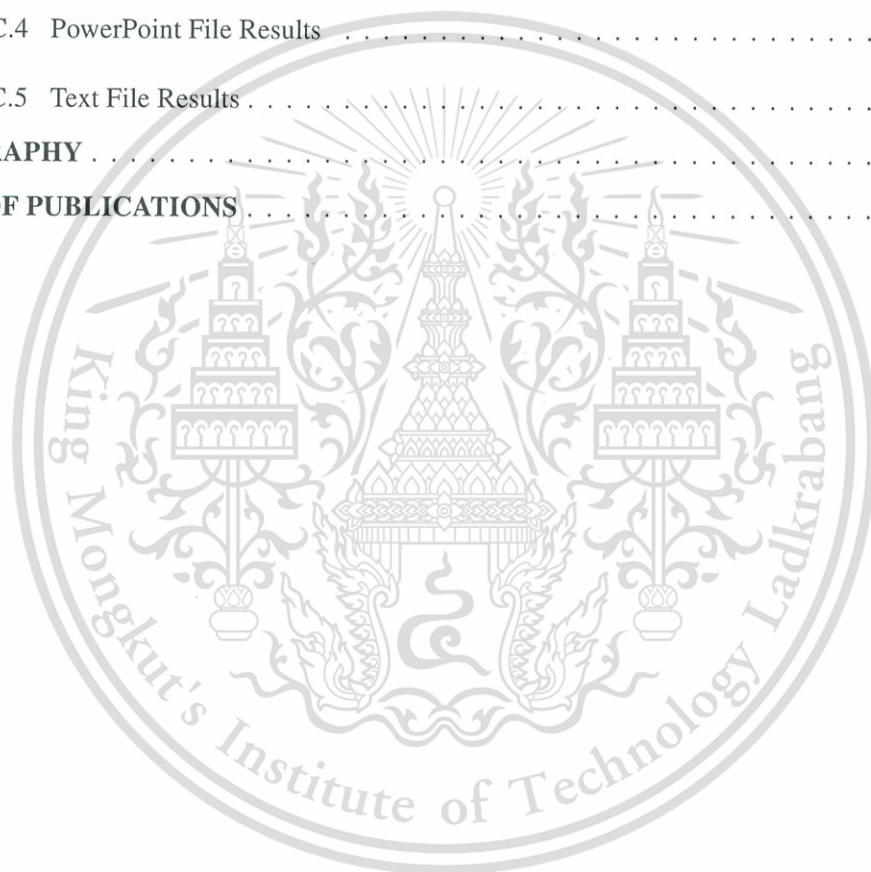

LIST OF FIGURES

Figure	Page
2.1 Block diagram of VLC	4
2.2 VPAN device architecture	6
2.3 FDM separation of the PHY types in the modulation domain [3]	7
2.4 Block diagram of OOK [3]	7
2.5 Block diagram of VPPM [3]	7
2.6 Block diagram of CSK [3]	8
2.7 Data format of serial transmission [31]	10
2.8 Structure of photodiode [34]	13
2.9 Equivalent circuit of a photodiode [34]	13
3.1 Schematic of transmitter	16
3.2 Schematic of receiver	17
3.3 Serial data format	17
3.4 Specification of PHY I [3]	18
3.5 The experimental setup	19
3.6 Transmitter interface	20
3.7 Receiver interface	20
3.8 Block diagram of the data transmission	21
3.9 Data format for data transmission [3]	21
3.10 A 2 octet CRC-16 HCS [3]	21
3.11 Block diagram of PRBS31	22
3.12 Transmitter interface for BER test	22
3.13 Receiver interface for BER test	23
3.14 Image file to be sent by the transmitter	24
4.1 Transceiver	25
4.2 The result of data transmission with certain data rate	26
4.3 Summary of BER test	26
4.4 Average of BER	27
4.5 BER result	27
4.6 Data format	28

This material is reserved for educational use only, not allowed for commercial use.

Forbidden to modify the content, and cite the document when use.

Figure	Page
4.7 BER result S1 varied in distance	28
4.8 BER result S2 varied in distance	29
4.9 BER result S3 varied in distance	29
4.10 BER result S5 varied in distance	30
4.11 BER result S8 varied in distance	30
4.12 BER result S13 varied in distance	31
4.13 BER result S21 varied in distance	31
4.14 BER result S30 varied in distance	32
4.15 Summary of relationship between BER and distance	32
4.16 Result of the successful character	33
4.17 Result of the one character missed received data	33
4.18 Result of the fail received data	33
4.19 Distance vs illumination	34
4.20 Distance vs optical power	35
4.21 Result of data transmission	35
4.22 Result of audio file transmission	36
4.23 Result of GIF file transmission	36
4.24 Result of PNG file transmission	37
4.25 Result of MS Excel file transmission	37
4.26 Result of MS Word file transmission	38
4.27 Result of PDF file transmission	39
4.28 Result of MS PowerPoint file transmission	39
4.29 Result of Text file transmission	40
A.1 Result of audio file transmission in repetition 1	48
A.2 Result of audio file transmission in repetition 2	48
A.3 Result of audio file transmission in repetition 3	48
A.4 Result of audio file transmission in repetition 4	48
A.5 Result of audio file transmission in repetition 5	48
A.6 Result of audio file transmission in repetition 6	48
A.7 Result of audio file transmission in repetition 7	49
A.8 Result of audio file transmission in repetition 8	49
A.9 Result of audio file transmission in repetition 9	49

This material is reserved for educational use only, not allowed for commercial use.

Figure	Page
A.10 Result of audio file transmission in repetition 10	49
B.1 GIF file transmission result in repetition 1	50
B.2 GIF file transmission result in repetition 2	50
B.3 GIF file transmission result in repetition 3	50
B.4 GIF file transmission result in repetition 4	51
B.5 GIF file transmission result in repetition 5	51
B.6 GIF file transmission result in repetition 6	51
B.7 GIF file transmission result in repetition 7	52
B.8 GIF file transmission result in repetition 8	52
B.9 GIF file transmission result in repetition 9	52
B.10 GIF file transmission result in repetition 10	53
B.11 PNG file transmission result in repetition 1	53
B.12 PNG file transmission result in repetition 2	53
B.13 PNG file transmission result in repetition 3	54
B.14 PNG file transmission result in repetition 4	54
B.15 PNG file transmission result in repetition 5	54
B.16 PNG file transmission result in repetition 6	55
B.17 PNG file transmission result in repetition 7	55
B.18 PNG file transmission result in repetition 8	55
B.19 PNG file transmission result in repetition 9	56
B.20 PNG file transmission result in repetition 10	56
C.1 Result of Excel file in repetition 1 that needs a recovery process	57
C.2 Result of Excel file in repetition 1 after the recovery process	57
C.3 Result of Excel file in repetition 2 that needs a recovery process	57
C.4 Result of Excel file in repetition 2 after the recovery process	58
C.5 Result of Excel file in repetition 3 that needs a recovery process	58
C.6 Result of Excel file in repetition 3 after the recovery process	58
C.7 Result of Excel file in repetition 4 that needs a recovery process	58
C.8 Result of Excel file in repetition 4 after the recovery process	59
C.9 Result of Excel file in repetition 5 that needs a recovery process	59
C.10 Result of Excel file in repetition 5 after the recovery process	59
C.11 Result of Excel file in repetition 6 that needs a recovery process	60

This material is reserved for educational use only, not allowed for commercial use.

Figure	Page
C.12 Result of Excel file in repetition 6 after the recovery process	60
C.13 Result of Excel file in repetition 7 that needs a recovery process	60
C.14 Result of Excel file in repetition 7 after the recovery process	60
C.15 Result of Excel file in repetition 8 that needs a recovery process	60
C.16 Result of Excel file in repetition 8 after the recovery process	61
C.17 Result of Excel file in repetition 9 that needs a recovery process	61
C.18 Result of Excel file in repetition 9 after the recovery process	61
C.19 Result of Excel file in repetition 10 that needs a recovery process	61
C.20 Result of Excel file in repetition 10 after the recovery process	61
C.21 Result of Word file in repetition 1 that needs a recovery process	62
C.22 Result of Word file in repetition 1 after the recovery process	62
C.23 Result of Word file in repetition 2 that needs a recovery process	62
C.24 Result of Word file in repetition 2 after the recovery process	62
C.25 Result of Word file in repetition 3 that needs a recovery process	63
C.26 Result of Word file in repetition 3 after the recovery process	63
C.27 Result of Word file in repetition 4 that needs a recovery process	63
C.28 Result of Word file in repetition 4 after the recovery process	63
C.29 Result of Word file in repetition 5 that needs a recovery process	64
C.30 Result of Word file in repetition 5 after the recovery process	64
C.31 Result of Word file in repetition 6 that needs a recovery process	64
C.32 Result of Word file in repetition 6 after the recovery process	64
C.33 Result of Word file in repetition 7 that needs a recovery process	65
C.34 Result of Word file in repetition 7 after the recovery process	65
C.35 Result of Word file in repetition 8 that needs a recovery process	65
C.36 Result of Word file in repetition 8 after the recovery process	65
C.37 Result of Word file in repetition 9 that needs a recovery process	66
C.38 Result of Word file in repetition 9 after the recovery process	66
C.39 Result of Word file in repetition 10 that needs a recovery process	67
C.40 Result of Word file in repetition 10 after the recovery process	67
C.41 Result of PDF file in repetition 1 after through the recovery process	68
C.42 Result of PDF file in repetition 2 after through the recovery process	68
C.43 Result of PDF file in repetition 3 after through the recovery process	69

This material is reserved for educational use only, not allowed for commercial use.

Figure	Page
C.44 Result of PDF file in repetition 4 after through the recovery process	69
C.45 Result of PDF file in repetition 5 after through the recovery process	70
C.46 Result of PDF file in repetition 6 after through the recovery process	70
C.47 Result of PDF file in repetition 7 after through the recovery process	71
C.48 Result of PDF file in repetition 8 after through the recovery process	71
C.49 Result of PDF file in repetition 9 after through the recovery process	71
C.50 Result of PDF file in repetition 10 after through the recovery process	72
C.51 Result of PowerPoint file in repetition 1 that needs a recovery process	73
C.52 Result of PowerPoint file in repetition 1 after the recovery process	73
C.53 Result of PowerPoint file in repetition 2 that needs a recovery process	73
C.54 Result of PowerPoint file in repetition 2 after the recovery process	73
C.55 Result of PowerPoint file in repetition 3 that needs a recovery process	74
C.56 Result of PowerPoint file in repetition 3 after the recovery process	74
C.57 Result of PowerPoint file in repetition 4 that needs a recovery process	74
C.58 Result of PowerPoint file in repetition 4 after the recovery process	75
C.59 Result of PowerPoint file in repetition 5 that needs a recovery process	75
C.60 Result of PowerPoint file in repetition 5 after the recovery process	76
C.61 Result of PowerPoint file in repetition 6 that needs a recovery process	76
C.62 Result of PowerPoint file in repetition 6 after the recovery process	77
C.63 Result of PowerPoint file in repetition 7 that needs a recovery process	77
C.64 Result of PowerPoint file in repetition 7 after the recovery process	77
C.65 Result of PowerPoint file in repetition 8 that needs a recovery process	78
C.66 Result of PowerPoint file in repetition 8 after the recovery process	78
C.67 Result of PowerPoint file in repetition 9 that needs a recovery process	78
C.68 Result of PowerPoint file in repetition 9 after the recovery process	78
C.69 Result of PowerPoint file in repetition 10 that needs a recovery process	79
C.70 Result of PowerPoint file in repetition 10 after the recovery process	79
C.71 Result of Text file in repetition 1	80
C.72 Result of Text file in repetition 2	80
C.73 Result of Text file in repetition 3	80
C.74 Result of Text file in repetition 4	81
C.75 Result of Text file in repetition 5	81

This material is reserved for educational use only, not allowed for commercial use.

Figure	Page
C.76 Result of Text file in repetition 6	81
C.77 Result of Text file in repetition 7	81
C.78 Result of Text file in repetition 8	82
C.79 Result of Text file in repetition 9	82
C.80 Result of Text file in repetition 10	82



LIST OF TABLES

Table	Page
2.1 Arduino Mega 2560 specification [33]	11
2.2 Visible light spectrum [33]	11
2.3 Comparison of LEDs and LDs [10]	12
4.1 Result of various types of file transmission	41



LIST OF ABBREVIATIONS

cm	centimeter
kbps	kilo bit per second
LED	Light emitting diode
ns	nano second
VLC	Visible light communication
V/ μ s	Volt per microsecond



CHAPTER 1

INTRODUCTION

1.1 Introduction

Radio frequency (RF) is the most well-known media for wireless communication. It becomes the primary source to send data through the air. In recent years, RF-based wireless communication is facing its big limitations. It is not a low-cost system because to use its certain bandwidth, users need to obey the bandwidth regulation.

A visible light communication (VLC) is a kind of optical wireless communications that uses a visible light source as a transmission medium [1]. VLC has many applications, such as for indoor positioning system, vehicle-to-vehicle communication, and in an area that requires less or no electromagnetic interference (EMI) like in the hospital [2]. The last application becomes one of some important reasons why this kind of wireless communication is researched. Another reason is this kind of wireless communication is a free-to-use bandwidth, so it does not need any regulation to use it.

In 2011, IEEE already established a standard for VLC network so that users can use the technology in the same level [3]. Many researchers already conducted research in various fields using VLC. Sarbazi and Uysal did a research on performance evaluation of IEEE 802.15.7 PHY layer [4]. They compared each PHY type's performance. Klaver and Zuniga did a research on a platform for multi-hop VLC system [5]. They made a platform consisting of 20 transmitters and 4 photo sensors. Che *et al.* did a research on VLC transmitter based on IEEE 802.15.7 [6]. Chen *et al.* did a research on VLC performance based on LDPC code [7]. Li *et al.* did a research on the performance of VLC in weak illumination environment [8]. Han and Lu did a research on the performance improvement of VLC system using Reed-Solomon code [9]. They did it based on simulation. Eventhough some researchers including [4–9] already did the research about VLC, but only a few researchers that conducted a research based on the standard and some of them use a simulation-based, not yet an experiment-based.

1.2 Objective of the Research

This research aims to do a comprehensive analysis of VLC network by designing hardware and software based on the established standard and testing the system's performance.

This material is reserved for educational use only, not allowed for commercial use.

Forbidden to modify the content, and cite the document when use.

1.3 Methodology

The methodology consists of the following steps:

Step 1: Design and develop the VLC the system.

The VLC system consists of a pair of transceivers. A transceiver consists of a transmitter and a receiver. The transmitter utilizes a LED as the transmission source, along with the driver circuit and the receiver uses a photodiode to capture the light and convert the absence-presence of light into data. The interface to interact with the hardware is built using Visual C#. The interface is used to conduct the data transmission and performance test.

Step 2: Parameter decision for the performance test of the system.

In order to know the performance of the system, several tests will be conducted using several parameters. Those are chosen based on the need of the researcher to know how well the system perform. The parameters are throughput, distance, bit error rate, and type of files.

Step 3: Hardware experiment and analysis of the result

The experiment will be held in the laboratory. Each parameter for the performance will have its own experimental setup. The result will be analyzed and compared to the established standard.

1.4 Thesis Organization

This thesis contains five chapters and is briefly explained as follows.

1. Chapter 1 introduces the background of the research problem, motivation behind the research in performance investigation of VLC system.
2. Chapter 2 contains the literature reviews of this research. The basic theory of VLC and several theories about hardware's components are discussed.
3. Chapter 3 describes the methodology used throughout this research. The experimental setup and how to evaluate the result are also discussed.
4. Chapter 4 contains the results of the experiments and the discussion of the results.
5. Chapter 5 contains the conclusion of the research and the future work.

CHAPTER 2

LITERATURE REVIEW

2.1 Visible Light Communication

Visible light communications (VLC) is the name given to an optical wireless communication system that carries information by modulating light in the visible spectrum (400-700 nm) that is principally used for illumination [3, 10, 11]. The signal is carried by the light and encoded on top of it. The motivation to use the illumination light for communications is to save energy by exploiting the illumination to carry information and, at the same time to use technology that is “green” in comparison to radio frequency (RF) technology, while using the existing infrastructure of the lighting system [12]. The necessity to develop an additional wireless communication technology is the result of the almost exponential growth in the demand for high-speed wireless connectivity [12]. Applications of VLC include:

- indoor communication where it augments WiFi and cellular wireless communications [13] which follow the smart city concept [14];
- communication wireless links for the internet of things (IOT) [15];
- communication systems as part of intelligent transport systems (ITS) [16–23];
- wireless communication systems in hospitals [24–26];
- toys and theme park entertainment [27, 28]; and
- provision of dynamic advertising information through a smart phone camera [29].

The simple principle of VLC is to switch the LED lighting on and off at a speed higher than is perceptible to the human eye. Eyes are organs that can detect changes in light brightness and power when these changes occur over a long time scale, but they cannot perceive light that is switched on and off rapidly. The rule of thumb is eyes cannot perceive the switched light with a rate of 200 Hz. A photodiode, on the other hand, can easily recognize the rapid on-off modulation. It is a photodetector that produces an electrical current that is proportional to the optical power that is incident on the photodetector surface. This simple principle makes possible visible-light communications technology that supports both illumination and wireless communication using an LED.

This material is reserved for educational use only, not allowed for commercial use.

Forbidden to modify the content, and cite the document when use.

A VLC system consists of a pair of transceivers. The source of transmitter can be from a fluorescence lamp, LED, and another type of source, as long as the wavelength is in the range of visible light spectrum. The receiver's sensor can be a photosensor (LDR, photodiode, phototransistor), solar cell, even a camera. The block diagram of VLC is shown in Fig. 2.1.

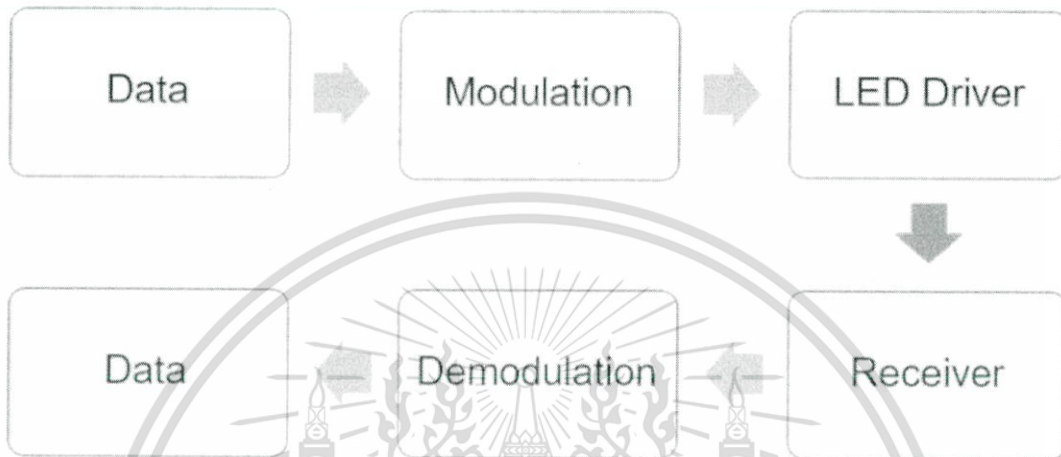

Figure 2.1: Block diagram of VLC

Figure 2.1 shows how a VLC works. It will be started from data, then the data through a process called modulation. It is a process where the original data is superimposed with the carrier signal. Then the modulated data is sent to the receiver through the light source, in this case, it is a LED. So, the data will be sent to the receiver in the bit form (0 and 1). In the receiver side, the transmitted data is received by the sensor, then it will through a process called demodulation, to get the original data. A VLC system needs a processor unit to do modulation and/or demodulation processes. It can be a personal computer (PC) or a microcontroller or other processors.

2.2 VLC Standard: IEEE 802.15.7

This is a standard from IEEE for short-range wireless optical communication using visible light. It contains a global standard to use VLC as a wireless personal area networks (WPAN). There are some characteristics found in this standard :

- Star, peer-to-peer, or broadcast operation.
- 16-bit short or 64-bit extended addresses.
- Scheduled or slotted random access with collision avoidance transmission.
- Fully acknowledged protocol for transfer reliability.

- Wavelength quality indication (WQI).
- Dimming support.
- Visibility support.
- Color function support.
- Color-stabilization support [3].

This standard architecture is defined in terms of a number of layers and sub-layers [3]. A VPAN device comprises of a PHY layer, which contains the light transceiver along with its low-level control mechanism, and a medium access control (MAC) sub-layer that provides access to the physical channel for all types of transfers [3]. The architecture is shown in Fig. 2.2.

This standard supports multiple PHY types:

1. PHY I: This PHY type is intended for outdoor usage with low data rate applications. This mode uses on-off keying (OOK) and variable pulse position modulation (VPPM) with data rates in the tens to hundreds of kilo bit per second (kbps).
2. PHY II: This PHY type is intended for indoor usage with moderate data rate applications. This mode uses OOK and VPPM with data rates in the tens of mega bit per second (Mbps).
3. PHY III: This PHY type is intended for applications using color-shift keying (CSK) that have multiple light sources and detectors. This mode uses CSK with data rates in the tens of Mbps.

The PSDU (PHY Service Data Unit). It is prefixed with a synchronization header (SHR), containing the preamble sequence field, and a PHY header (PHR), which, among other things, contains the length of the PSDU in octets. The preamble sequence enables the receiver to achieve synchronization. The SHR, PHR, and PSDU together form the PHY frame or PHY layer data unit (PPDU) [3].

The PHY types coexist but do not interoperate. PHY I and PHY II occupy different spectral regions in the modulation-domain spectrum, which enables frequency division multiplexing (FDM) as a coexistence mechanism (shown in Fig. 2.3). PHY I and PHY III also occupy different spectral regions in the modulation-domain spectrum, with different data rates and different optical rate support, providing coexistence. However, the optical clock frequencies used for PHY II

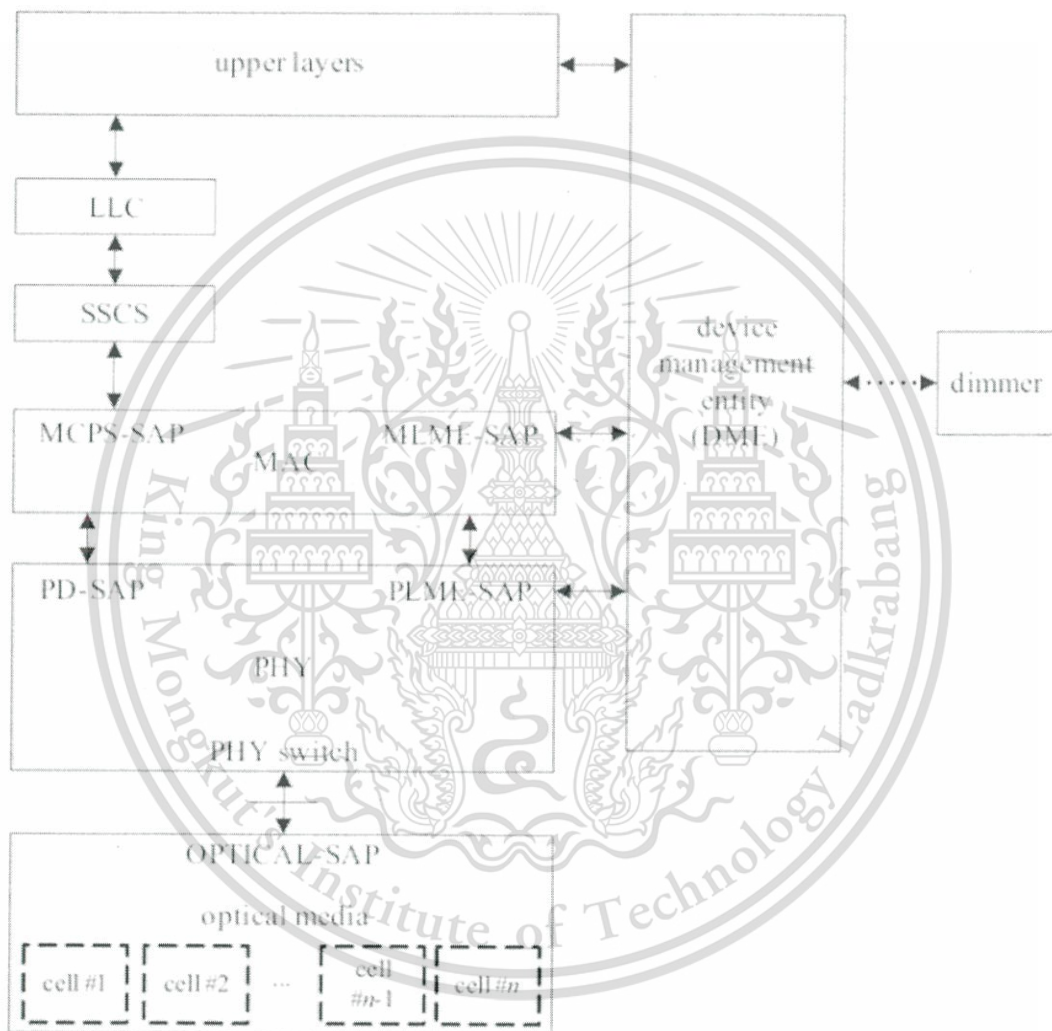

Figure 2.2: VPAN device architecture

and PHY III overlap, causing significant overlap in the frequency domain spectrum. In addition, not all devices support multiple optical frequency bands needed for PHY III. Hence, all PHY III devices use a PHY II device for device discovery to support coexistence with PHY II.

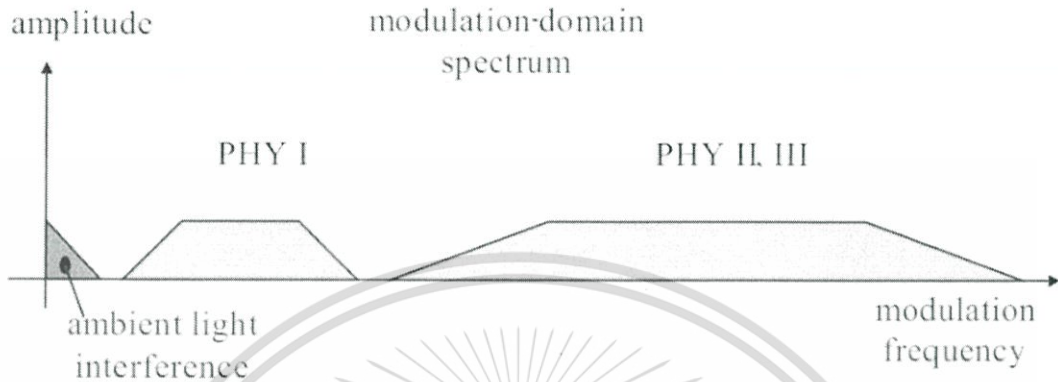

Figure 2.3: FDM separation of the PHY types in the modulation domain [3]

The ways how each modulation works are shown in Fig. 2.4, 2.5, and 2.6.

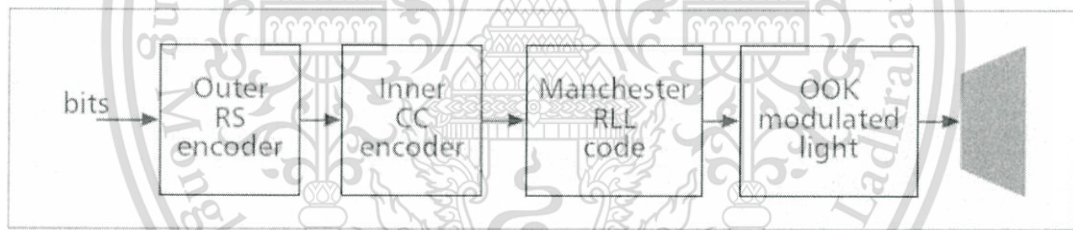

Figure 2.4: Block diagram of OOK [3]

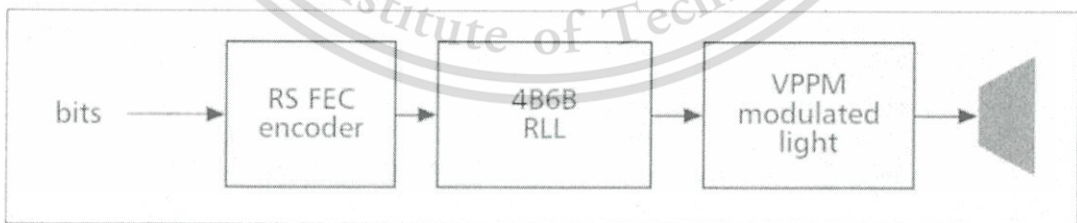

Figure 2.5: Block diagram of VPPM [3]

2.3 Baseband Modulation

Selecting a modulation technique is one of the key technical decisions in the design of any communication system. Before selection can take place, it is necessary to define the criteria on which the various modulation techniques are to be assessed. For the optical wireless channel,

This material is reserved for educational use only, not allowed for commercial use.

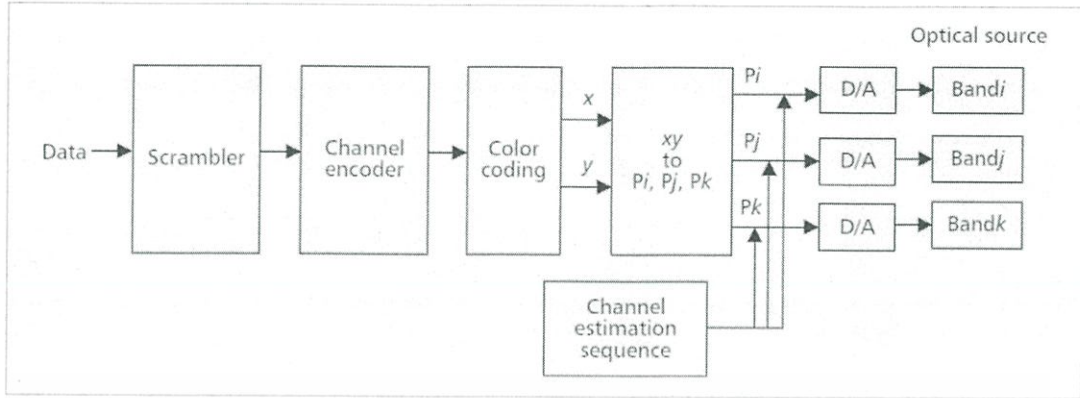

Figure 2.6: Block diagram of CSK [3]

these criteria are listed below in order of decreasing importance [22].

1. *Power efficiency*: In order to comply with the eye and skin safety regulations, the average optical power emitted by an optical wireless transmitter is limited. Furthermore, in portable battery-powered equipment, it is desirable to keep the electrical power consumption to a minimum, which also imposes limitations on the optical transmit power. Consequently, the most important criterion when evaluating the modulation techniques suitable for indoor optical wireless communication systems is the power efficiency. Each of these modulation schemes offers a certain optical average power, and therefore they are usually compared in terms of the average optical power required to achieve a desired bit error ratio (BER) performance or signal-to-noise ratio (SNR). The power efficiency η_p of a modulation scheme is given by the average power required to achieve a given BER at a given data rate. Mathematically, η_p is defined as

$$\eta_p = \frac{E_{pulse}}{E_b} \quad (2.1)$$

where E_{pulse} is the energy per pulse and E_b is the average energy per bit.

2. *Bandwidth efficiency*: Although the optical carrier can be theoretically considered as having an 'unlimited bandwidth', the other constituents (photodetector area, channel capacity) in the system limit the amount of bandwidth that is practically available for a distortion-free communication system. Also, the ensuing multipath propagation in diffuse link/nondirected line-of-sight (LOS) limits the available channel bandwidth. This also makes the bandwidth efficiency a prime metric. The bandwidth efficiency η_B is defined as

$$\eta_B = \frac{R_b}{B} \quad (2.2)$$

This material is reserved for educational use only, not allowed for commercial use.

Forbidden to modify the content, and cite the document when use.

where R_b is the achievable bit rate and B is the bandwidth of the IR transceiver. The relationship between bandwidth and power efficiencies depends on the average duty cycle γ given by

$$\eta_p = \frac{\eta B}{\gamma}. \quad (2.3)$$

When the shot noise is the dominant noise source, the received SNR is proportional to the photodetector surface area. Consequently, single-element receivers favour the use of large-area photodetectors. However, the high capacitance associated with large-area photodetectors has a limiting effect on the receiver bandwidth. In addition to this, for nondirected LOS and diffuse link configurations, the channel bandwidth is limited by multipath propagation. Therefore, it follows that modulation schemes which have a high bandwidth requirement are more susceptible to intersymbol interference (ISI), and consequently incur a greater power penalty. Thus, the second most important criterion when evaluating modulation techniques is the bandwidth efficiency.

3. *Transmission reliability*: A modulation technique should be able to offer a minimum acceptable error rate in adverse conditions as well as show resistance to the multipath-induced ISI and variations in the data signal DC component. A long absence of '0 to 1' transition may be problematic as the clock recovery by a digital phase-locked loop (DPLL) might not be feasible. Moreover, multiple consecutive high pulses should be avoided, since the resulting signal would be distorted by the high-pass filter (HPF) in the receiver. In addition, the modulation technique should be resistant to a number of factors such as the phase jitter due to variations of the signal power, pulse extensions due to diffusion component larger time constant and pulse distortion due to near-field signal clipping.
4. *Other considerations*: Optical wireless transceivers intended for mass-market applications are likely to have tight cost constraints imposed upon them. Consequently, it is highly desirable that the chosen modulation technique is rather simple to implement. Achieving excellent power efficiency and/or bandwidth efficiency is of little use if the scheme is so complex to implement that cost renders it unfeasible. Another consideration when evaluating modulation techniques is the ability to reject the interference emanating from artificial sources of ambient light. The simplest method to reduce the power level of the ambient light is to use electrical high-pass filtering. Consequently, it is desirable that the chosen modulation technique does not have a significant amount of its power located at DC and low frequencies, thereby reducing the effect of baseline wander and thus permitting the

This material is reserved for educational use only, not allowed for commercial use.

Forbidden to modify the content, and cite the document when use.

use of higher frequencies. In addition to this, if the chosen modulation technique is required to operate at medium to high data rates over non directed LOS or diffuse links, multipath dispersion becomes an issue. Consequently, it is also desirable that the scheme be resistant to ISI resulting from multipath propagation.

2.4 Universal Asynchronous Receiver/Transmitter (UART)

The Universal Asynchronous Receiver/Transmitter (UART) is a device that converts a serial stream of bits arriving over a single wire into a character that can be read in parallel form by a microprocessor connected to the UART by a parallel bus [30]. This hardware uses an RS-232C protocol. It is one of several I/O standards. It contains 8 bits for one data transmission and it is sent one bit at a time serially. The data format of serial transmission is shown in Fig. 2.7. The data will be started with a start bit, followed by 8 bits data, then end with stop bit. This kind of transmission uses a clock signal to clock in and out individual bits serially, and the frequency of this bit clock is called the serial interface's baud rate [31]. The baud rate commonly ranges from 300 to 115200 bps.

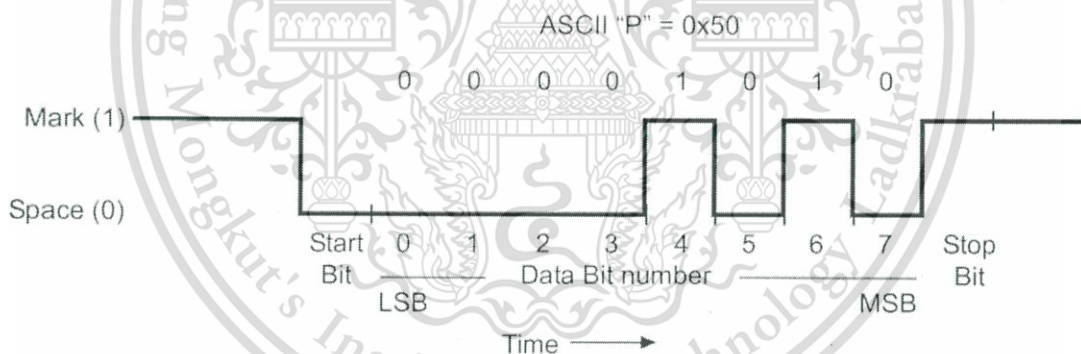

Figure 2.7: Data format of serial transmission [31]

2.5 Microcontroller

2.5.1 Arduino Mega 2560 R3

Arduino Mega 2560 R3 is a microcontroller board produced by Arduino®. It is based on ATmega2560 produced by Atmel®. It has 54 digital input/output pins (of which 15 can be used as PWM outputs), 16 analog inputs, 4 UARTs (hardware serial ports), a 16 MHz crystal oscillator, a USB connection, a power jack, an ICSP header, and a reset button [32]. The detail specification is shown in the Table 2.1. It contains everything needed to support the microcontroller; simply connect it to a computer with a USB cable or power it with a AC-to-DC adapter or battery to get

started.

Table 2.1: Arduino Mega 2560 specification [33]

Specification	Arduino Mega 2560
Microcontroller	ATmega2560
Operating Voltage	5V
Input Voltage (recommended)	7-18V
Input Voltage (limits)	6-20V
Digital I/O Pins	54 (of which 15 provide PWM output)
Analog Input Pins	16
DC Current per I/O Pin	40 mA
DC Current for 3.3V Pin	50 mA
Flash Memory	256 KB
SRAM	8 KB (ATmega2560)
EEPROM	4 KB (ATmega2560)
Clock Speed	16 MHz

2.6 VLC Transmitter

2.6.1 Visible Light

Visible light is a kind of electromagnetic waves that has range of spectrum around 400-700 nm. The detail of the spectrum is shown in Table. 2.2.

Table 2.2: Visible light spectrum [33]

Color	Wavelength (m)	Frequency (Hz)
Purple	$3.9 - 4.5 \times 10^{-7}$	$6.7 - 7.7 \times 10^{14}$
Blue	$4.5 - 4.9 \times 10^{-7}$	$6.1 - 6.7 \times 10^{14}$
Green	$4.9 - 5.8 \times 10^{-7}$	$5.3 - 6.1 \times 10^{14}$
Yellow	$5.8 - 6.0 \times 10^{-7}$	$5.1 - 5.3 \times 10^{14}$
Orange	$6.0 - 6.2 \times 10^{-7}$	$4.8 - 5.1 \times 10^{14}$
Red	$6.2 - 7.7 \times 10^{-7}$	$3.9 - 4.8 \times 10^{14}$

2.6.2 Light Emitting Diode (LED)

In VLC, there are two basic source choices, the light emitting diode (LED) and the laser diode (LD). The choice between LEDs and LDs depends on the application and the configuration where they are to be used. LEDs are preferred for hybrid LOS or non-LOS short distance indoor applications that require some degree of mobility. This is because, as they emit a broad beam, careful alignment of the receiver and the transmitter is not required. Also, LEDs are generally cheaper and harder to damage than LDs, and they are allowed to emit higher optical powers without damaging the human eye. Another advantage is LED driver circuits are simpler and LEDs do not require stabilization against temperature variations. LDs, on the other hand, are This material is reserved for educational use only, not allowed for commercial use.

often preferred for high-speed directed-LOS links in outdoor applications as the emission beam of these sources is narrow. This means that the optical power per unit area is higher allowing for longer transmission distances. Also, LDs can be used at higher modulation rates than LEDs, allowing for high-speed data communication transmission. The major disadvantages from LDs are the driver circuit of LDs is more complicated and the emitted power is limited due to eye safety considerations. Furthermore, LDs are sensitive to temperature variations that modify their spectral emission [10]. All differences between LEDs and LDs are summarized in Table 2.3.

Table 2.3: Comparison of LEDs and LDs [10]

Characteristic	LED	LD
Optical spectral width	25 - 100 nm	$<10^{-5}$ - 5 nm
Directionality	Broad (divergence $> 15^\circ$)	Narrow ($< 10^\circ$)
Modulation bandwidth	\sim kHz to \sim MHz	\sim kHz to \sim GHz
Special circuitry required	None	Threshold and temperature compensation
Eye safety	Considered eye safe	May need to be rendered eye safe
Reliability	High	Moderate
E/O conversion efficiency	10-20%	30-70%
Cost	Low	Moderate to High

2.7 VLC Receiver

2.7.1 Photodiode

Photodiodes are kind of semiconductive optical sensors. In a simple way, the operation of a photodiode can be described as follows. If a p-n junction is forward biased (positive side of a battery is connected to the p side) and is exposed to light of proper frequency, the current increase will be very small with respect to a dark current [34]. In other words, the bias current is much greater than the current generated by light. If the junction is *reverse biased* (Figure 2.8), the current will increase quite noticeably. Impinging photons create electron-hole pairs on both sides of the junction. When electrons enter the conduction band, they start flowing toward the positive side of the battery. Correspondingly, the created holes flow to the negative terminal, meaning that the photocurrent i_p flows in the network. Under dark conditions, the leakage current i_0 is independent of applied voltage and mainly is the result of thermal generation of charge carriers. Thus, a reverse-biased photodiode electrical equivalent circuit (Figure 2.9) contains two current sources and an RC network.

The process of optical detection involves the direct conversion of optical energy (in the form of photons) into electrical energy (in the form of electrons and holes). This material is reserved for educational use only, not allowed for commercial use.

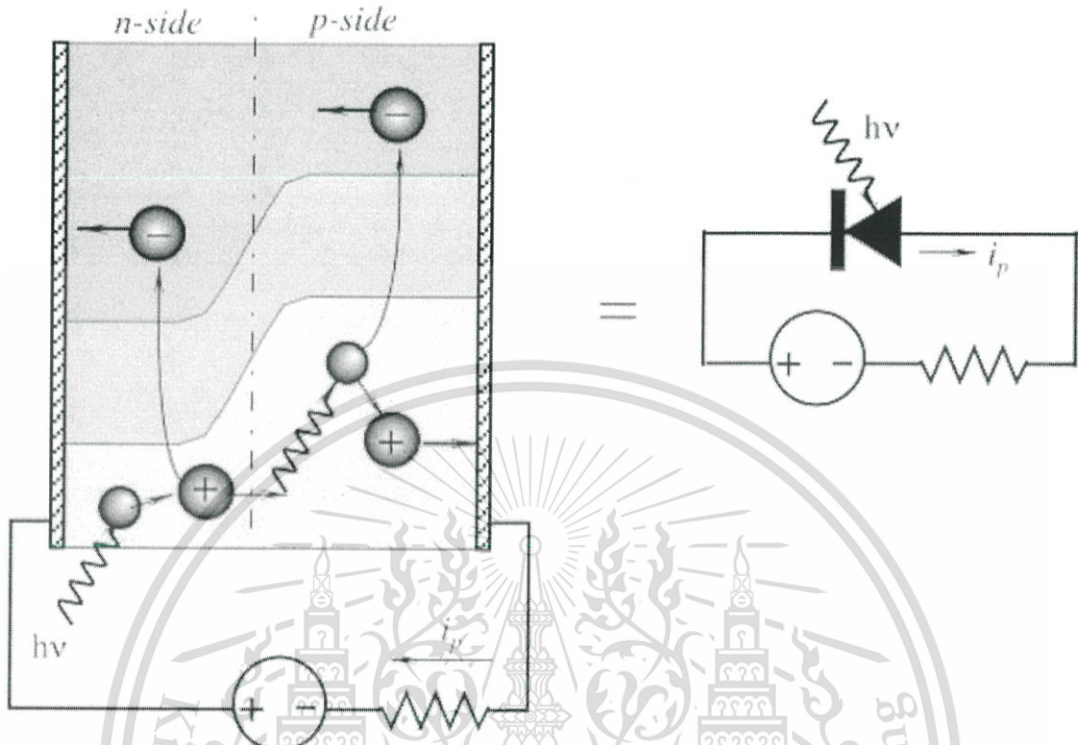

Figure 2.8: Structure of photodiode [34]

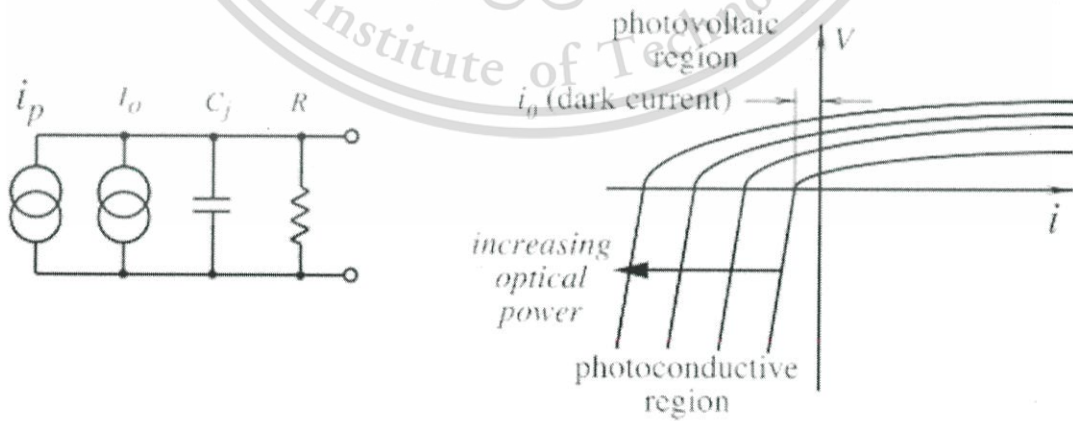

Figure 2.9: Equivalent circuit of a photodiode [34]

of photons) into an electrical signal (in the form of electrons). If the probability that a photon of energy $h\nu$ will produce an electron in a detection is η , then the average rate of production of electrons $\langle r \rangle$ for an incident beam of optical power P is given by

$$\langle r \rangle = \frac{\eta P}{h\nu}. \quad (2.4)$$

The production of electrons due to the incident photons at constant rate $\langle r \rangle$ is randomly distributed in time and obeys Poisson statistics, so that the probability of the production of m electrons in some measurement interval τ is given by

$$p(m, \tau) = (\langle r \rangle \tau)^m \frac{1}{m!} e^{-\langle r \rangle \tau}. \quad (2.5)$$

The statistics involved with optical detection are very important in the determination of minimum detectable signal levels and, hence, the ultimate sensitivity of the sensors. At this point, however, we just note that the *electrical current is proportional to the optical power* incident on the detector:

$$i = \langle r \rangle e = \frac{\eta e P}{h\nu}, \quad (2.6)$$

where e is the charge of an electron. A change in input power ΔP (e.g., due to intensity modulation in a sensor) results in the output current Δi . Because power is proportional to squared current, the detector's electrical power output varies quadratically with input optical power, making it a "square-law" detector.

The voltage-to-current response of a typical photodiode is shown in Figure 2.9. If we attach a high-input-impedance voltmeter to the diode (corresponds to the case when $i = 0$), we will observe that with increasing optical power, the voltage changes in a quite nonlinear fashion. In fact, variations are logarithmic. For the short-circuit conditions ($V = 0$), [i.e., when the diode is connected to a current-to-voltage converter], current varies linearly with the optical power. The current-to-voltage response of the photodiode is given by

$$i = i_0(e^{eV/k_b T} - 1) - i_s, \quad (2.7)$$

where i_0 is a reverse "dark current" which is attributed to the thermal generation of electron-hole pairs, i_s is the current due to the detected optical signal, k_b is Boltzmann constant, and T is the

absolute temperature. Combining Eq. 2.6 and 2.7 yields

$$i = i_0(e^{eV/k_bT} - 1) - \frac{\eta e P}{h\nu}, \quad (2.8)$$

which is the overall characteristic of a photodiode.

In general, depending on the function and construction, all photodiodes may be classified as follows:

1. The *PN photodiodes* may include a SiO₂ layer on the outer surface. This yields a low-level dark current. To fabricate a high-speed version of the diode, the depletion layer is increased, thus reducing the junction capacitance. To make the diode more sensitive to ultraviolet (UV) light, a *p* layer can be made extra thin. A version of the planar diffusion type is a *pnn*⁺ diode, which has a lower sensitivity to infrared and higher sensitivity at shorter wavelengths. This is due primarily to a thick layer of a low-resistance *n*⁺ silicon to bring the *nn*⁺ boundary closer to the depletion layer.
2. The *PIN photodiodes* are an improved version of low-capacitance planar diffusion diodes. The diode uses an extra high-resistance *I* layer between the *p* and *n* layers to improve the response time. These devices work even better with reversed bias, therefore, they are designed to have low leakage current high breakdown voltage.
3. The Schottky photodiodes have a thin gold coating sputtered onto the *n* layer to form a Schottky p-n junction. Because the distance from the outer surface to the junction is small, the UV sensitivity is high.
4. The *avalanche photodiodes* are named so because if a reverse bias is applied to the p-n junction and a high-intensity field is formed with the depletion layer, photon carriers will be accelerated by the field and collide with the atoms, producing the secondary carriers. In turn, the new carriers are accelerated again, resulting in the extremely fast avalanche-type increase in current. Therefore, these diodes work as amplifiers, making them useful for detecting extremely low levels of light.

CHAPTER 3

VLC SYSTEM AND EXPERIMENTAL SETUP

In this chapter, the VLC system and the experimental setup are discussed. It consists of two sections, which are the explanation of the VLC system and the explanation of the experimental setup.

3.1 Transceiver

The transceiver consists of a transmitter and a receiver. As shown in Fig. 3.1, the transmitter circuit consists of a light emitting diode (LED) and a logic buffer. The purpose of using a logic buffer is to give enough current to turn on the LED. Also, it gives enough current to drive the LED when it sends the data using UART. The decision to use the driver circuit is based on [1] and [2]. The previous design used without additional driver circuit, so when it was tried using UART, the transmission could not be done. Another reason is the maximum data rate can be reached using the circuit design in [1] and [2] is 1 kbps. The receiver circuit, as shown in Fig. 3.2, consists of a photodiode and a driver circuit. An SFH203P is a photodiode used as the receiver. It is used because it has very short rise/fall time, which is 5 ns [35]. Rise/fall time is a time needed for the sensor to receive the impulse, which is the presence or absence of the light. The purpose of using an operational amplifier is to buffer the current so there are no data lost. A TSV992AIDT is an operational amplifier used in the circuit. It is used because it has a moderate slew rate, which is 10 V/ μ s [36]. Slew rate is a parameter explains about the maximum rate of an amplifier when it receives an abrupt change of input level.

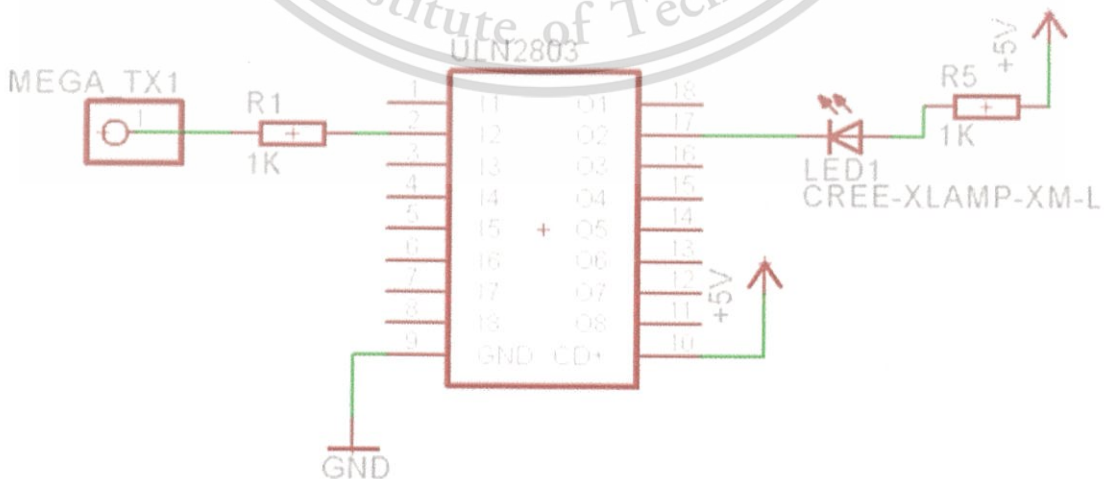

Figure 3.1: Schematic of transmitter

This material is reserved for educational use only, not allowed for commercial use.

Forbidden to modify the content, and cite the document when use.

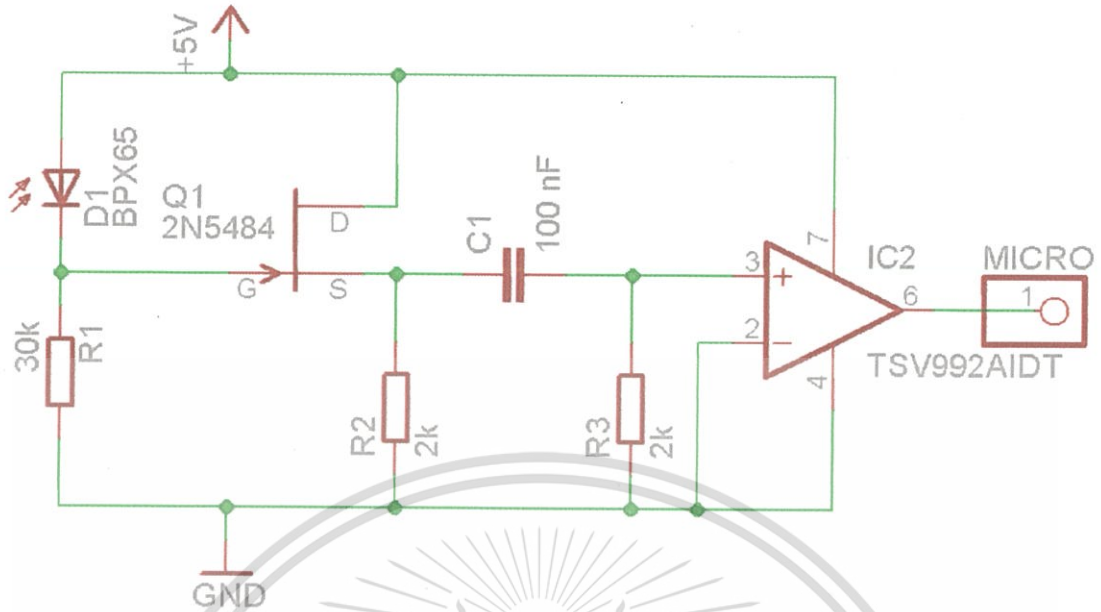

Figure 3.2: Schematic of receiver

The controller used in the system is Arduino Mega 2560. It is used because it has more than one hardware serial [32]. The data are sent through serial transmission, in which the format is shown in Fig. 3.3. According to [3] and Fig. 3.4, the system will focus on using the maximum speed in the on-off keying (OOK) modulation, which is 100 kbps. The system will be tested in a peer-to-peer network topology.



Figure 3.3: Serial data format

3.2 Experimental Setup

The experiment is conducted at Wireless Information Network (WIN) Laboratory, Department of Computer Engineering, Faculty of Engineering, King Mongkut's Institute of Technology Ladkrabang. The experimental setup is set on a white table, as shown in Fig. 3.5. The transmitter (left black box) will send data to the receiver (right black box). The data is sent using a transmitter interface, as shown in Fig. 3.6, through the transmitter using UART, the transmitter send the data wirelessly to the receiver, and it is received using a receiver interface, as shown in Fig. 3.7. The block diagram of the data transmission is shown in Fig. 3.8. The transmitter interface consists of several parameters to be set:

This material is reserved for educational use only, not allowed for commercial use.

Forbidden to modify the content, and cite the document when use.

Modulation	RLL code	Optical clock rate	FEC		Data rate
			Outer code (RS)	Inner code (CC)	
OOK	Manchester	200 kHz	(15,7)	1/4	11.67 kb/s
			(15,11)	1/3	24.44 kb/s
			(15,11)	2/3	48.89 kb/s
			(15,11)	none	73.3 kb/s
			none	none	100 kb/s
VPPM	4B6B	400 kHz	(15,2)	none	35.56 kb/s
			(15,4)	none	71.11 kb/s
			(15,7)	none	124.4 kb/s
			none	none	266.6 kb/s

Figure 3.4: Specification of PHY I [3]

1. COM Port. It is used to select the right port to be used for the data transmission.
2. TDP. It will define which network topology employed in the data transmission. The choices are Topology Independent, Peer-to-peer, Star, and Broadcast. This research will use the Peer-to-peer topology.
3. Channel #. It will define which channel or range of wavelengths used in the data transmission. The range of the wavelength is around 400 to 700 nm. In this research, any channel number can be utilized, since the transmitter source is a white light.
4. MCS ID. It will set the data rate of transmission. In this research, 100 kbps is used.
5. Dimmed OOK. It will define whether the light is dimmed or not.
6. Burst Mode. It will define whether the data are in the burst mode or not.

The receiver interface layout is similar to the transmitter interface, but the receiver interface uses several boxes as read-only boxes. They are TDP box, Channel # box, MCS ID box, Dimmed OOK checkbox, and Burst Mode checkbox.

The data format used in this experiment is based on [3] and shown in Fig. 3.9. This format is started by a preamble field. It contains FLP (Fast Locking Pattern), TDP (Topology-Dependent Pattern), and inverted TDP. FLP is a 64-bits number containing a value of "10101010". This material is reserved for educational use only, not allowed for commercial use.

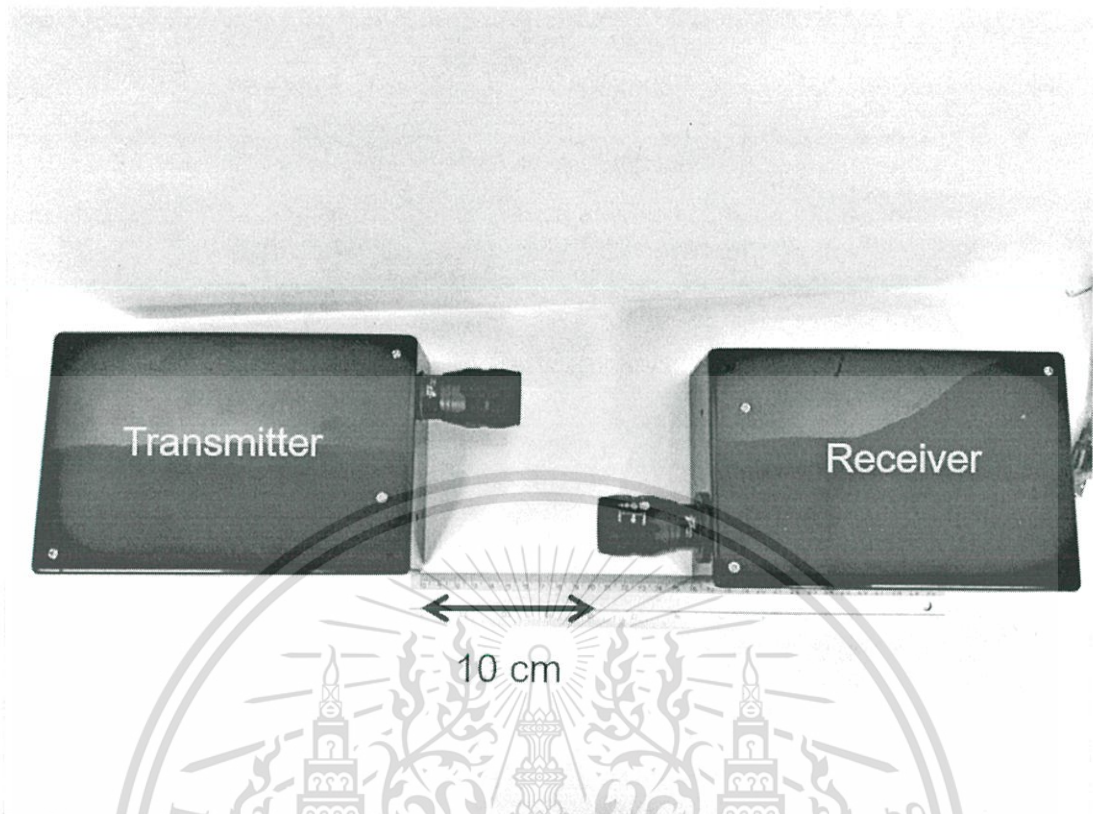

Figure 3.5: The experimental setup

..... 10101010" or "170 170 170 170" in decimal. TDP value depends on the topology. This experiment uses the P2 which is peer-to-peer topology and the value of TDP is "001011101111110" or 6014 in decimal. Burst mode is a 1-bit value, either 0 or 1. FCS (Frame Check Sequence) is calculated using 2 octets CRC-16 HCS, which the block diagram is shown in Fig. 3.10. In between FCS is an optional field, contains compensation length, resync length, and subframe length. Those have fixed values, which are 128, 15, and 0, respectively. After FCS, it is a data field, contains extension and data. Extension defines what is the file's extension sent in the transmission, either .png, .gif, .mp3, .txt, .docx, .xlsx, .pptx, or .pdf.

In order to know the performance of the system, several parameters are used. Those parameters are explained here.

3.2.1 Throughput

The throughput of the system will be compared to the IEEE standard, whether it can reach the maximum speed of 100 kbps. The data rate will be set for both transmitter and receiver, based on the choices of baud rate in UART, then the transmitter will send data contains a sequence of This material is reserved for educational use only, not allowed for commercial use.

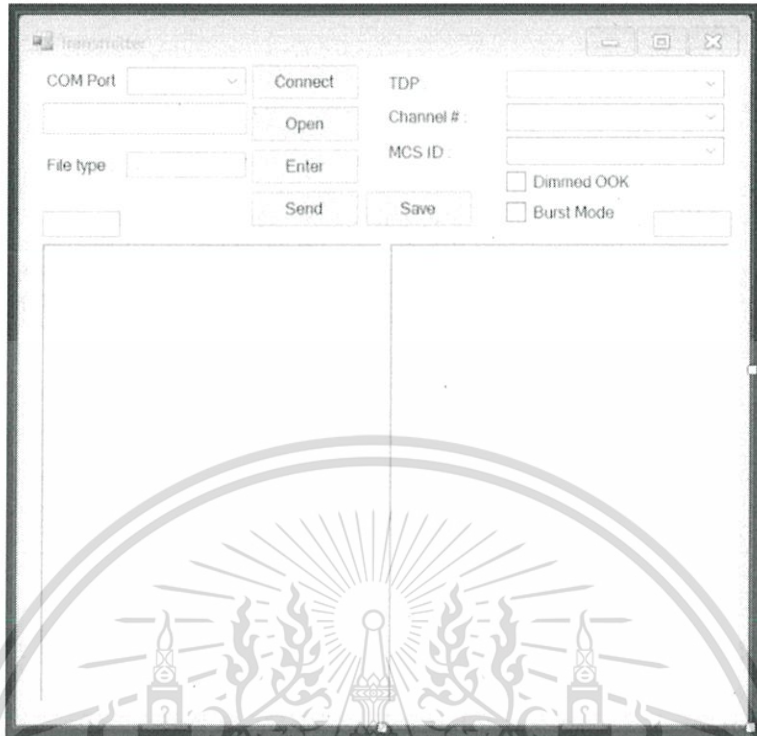

Figure 3.6: Transmitter interface



Figure 3.7: Receiver interface

This material is reserved for educational use only, not allowed for commercial use.

Forbidden to modify the content, 20 and cite the document when use.

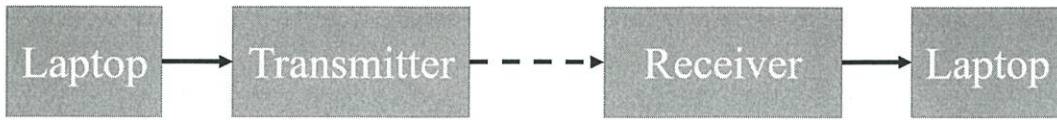

Figure 3.8: Block diagram of the data transmission

FLP	TDP	Inverted TDP	TDP	Inverted TDP	Burst mode	Channel #	MCS ID	Dimmed	FCS	Comp Length	Resync Length	Subframe	FCS	Ext	Data
-----	-----	--------------	-----	--------------	------------	-----------	--------	--------	-----	-------------	---------------	----------	-----	-----	------

Figure 3.9: Data format for data transmission [3]

$$\text{CRC-16 Generator Polynomial: } G(x) = x^{16} + x^{12} + x^5 + 1$$

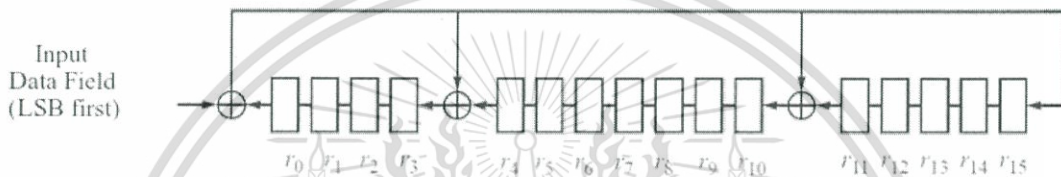

Figure 3.10: A 2 octet CRC-16 HCS [3]

numbers to the receiver and it is checked to the reference data sent by the transmitter, whether there is/are any missing byte(s). This parameter-based performance test will be conducted at the fixed distance of 10 cm.

3.2.2 Bit Error Rate

The system will be measured the number of errors produced in a single transmission by sending pseudo random data, which are generated using PRBS31 pattern generator. PRBS31 is a pseudo random binary sequence that has a formula of $x^{30} + x^{28} + 1$ and the block diagram is shown in Fig. 3.11. This method is inspired by [37]. The transmitter will send a data package containing the sequence generated from the pattern generator. The sequence starts from $2^1, 2^1 2^2$, until $2^1 2^2 \dots 2^{29} 2^{30}$. The sequences chosen for the test are S1 (2^1), S2 ($2^1 2^2$), S3 ($2^1 2^2 2^3$), S5 ($2^1 2^2 2^3 2^4 2^5$), S8 ($2^1 2^2 \dots 2^7 2^8$), S13 ($2^1 2^2 \dots 2^{12} 2^{13}$), S21 ($2^1 2^2 \dots 2^{20} 2^{21}$), and S30 ($2^1 2^2 \dots 2^{29} 2^{30}$). Those sequences are chosen to maintain the randomness of the test data. Every sequence is repeated 10 times for the fixed distance and 5 times in order to observe the relationship between BER and distance. The interfaces used in this test are shown in Fig. 3.12 and Fig. 3.13.

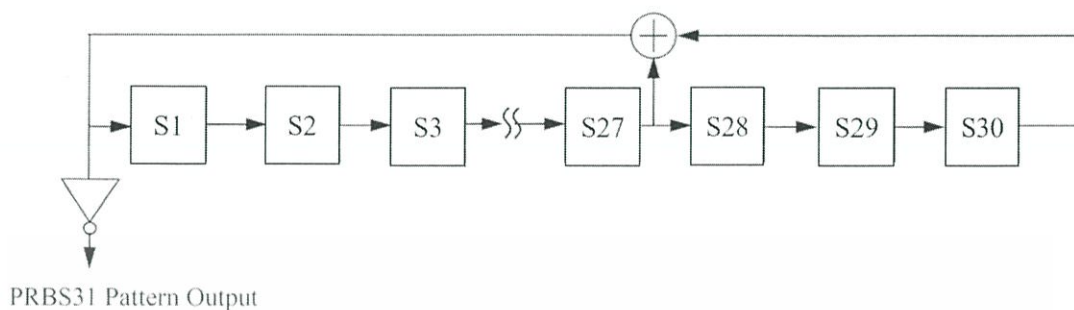

Figure 3.11: Block diagram of PRBS31

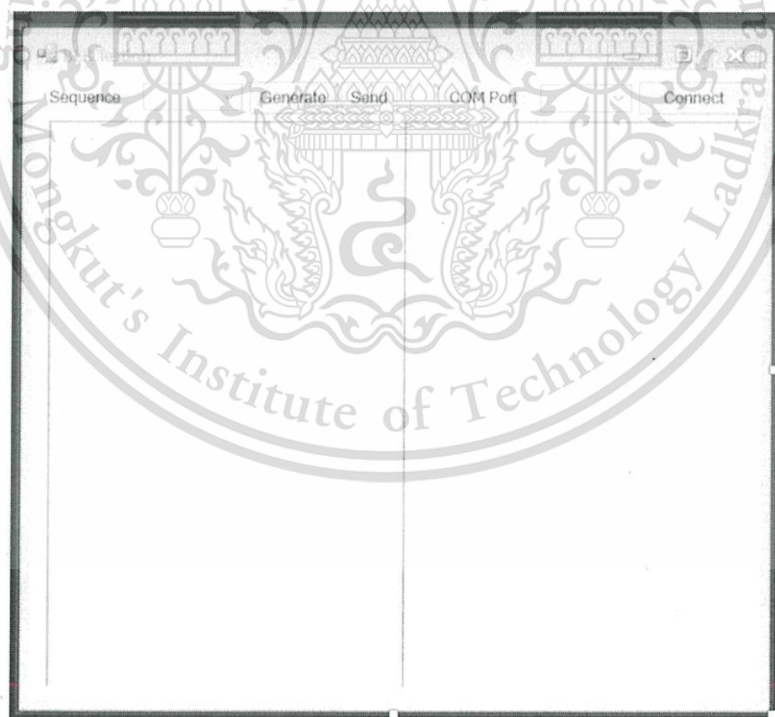

Figure 3.12: Transmitter interface for BER test

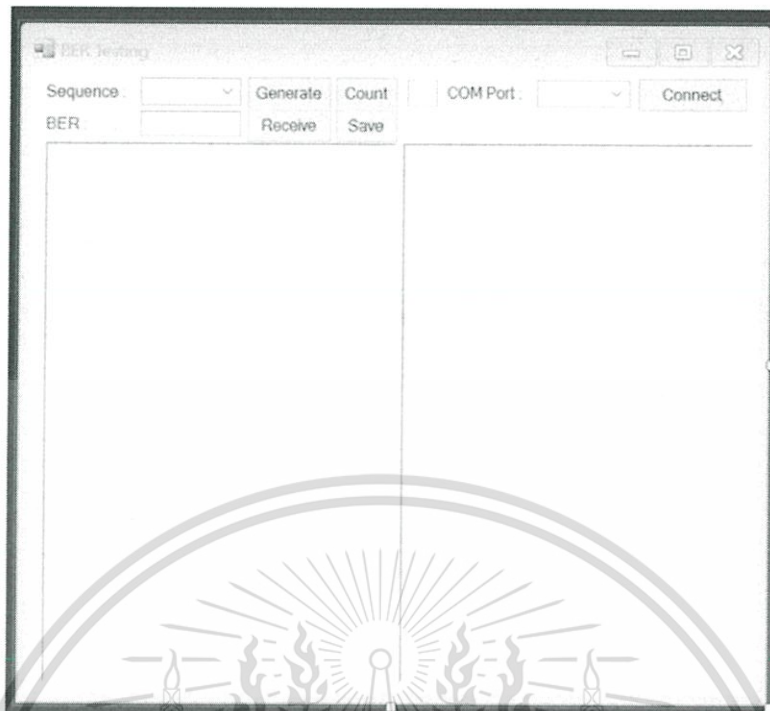

Figure 3.13: Receiver interface for BER test

3.2.3 Distance

The purpose of this parameter used in the performance test is to determine the maximum distance can be reached by the system for the data transmission. The transmitter will send a data sequence containing 39321 39321 39321 39321 39321 39321 39321 39321 39321 21845 21845 21845 21845 21845 21845 21845 2791741077 38229 21930 21845 39509 21865 23126 21913 to the receiver and then, it is compared to the reference data sequence sent by the transmitter. Those numbers are taken from the values of PHY I data format after being encoded using Manchester code. The distance range starts from 10 cm to the maximum distance can be reached by the system with an increment of 10 cm.

3.2.4 Types of file

The system will send various type of files, which are MS Word file (.docx), MS Excel file (.xlsx), MS Powerpoint file (.pptx), PDF file (.pdf), GIF file (.gif), PNG file (.png), audio file (.mp3), and text file (.txt). The file will be converted into a sequence of bytes before it is sent to the receiver by using the function in Microsoft Visual Studio. Each file will be repeated 10 times at the fixed distance, which is 10 cm. For GIF and PNG file, the reference image sent by the transmitter is shown in Fig. 3.14.

This material is reserved for educational use only, not allowed for commercial use.

Forbidden to modify the content and cite the document when use.

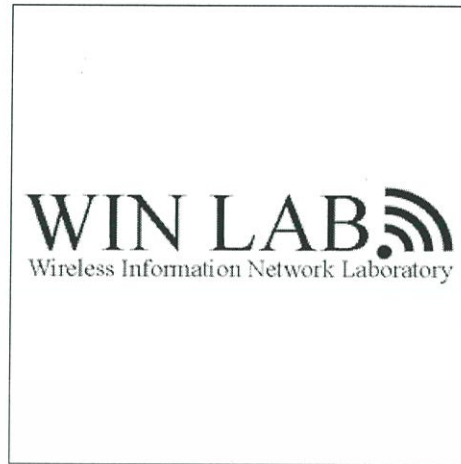

Figure 3.14: Image file to be sent by the transmitter

3.2.4.1 Document file

Files considered as a document file are MS Word file (.docx), MS Excel file (.xlsx), MS Powerpoint file (.pptx), PDF file (.pdf), and text file (.txt). Each of them includes the same sentence, which is "Wireless Information Network Laboratory, Department of Computer Engineering, Faculty of Engineering, King Mongkut's Institute of Technology Ladkrabang". File sizes are 12 kB, 9 kB, 34 kB, 161 kB, and 1 kB, respectively.

3.2.4.2 Image file

Image files used throughout this test are GIF (.gif) and PNG (.png). Those are selected because those are the two smallest among all types of image extension. The sizes of the image are 5 kB and 7 kB, respectively.

3.2.4.3 Audio file

The audio file used is an MP3 file (.mp3). It is a 2-second clip containing bell sound. The size is 11 kB.

CHAPTER 4

RESULTS AND DISCUSSIONS

In this chapter, the experimental results are shown and discussed.

4.1 Transceiver

The transceiver is shown in Fig. 4.1. The transmitter uses a lens in order to focus the light. In the experiment, the transmitter uses the lens in its maximum focus. The sensor is placed inside the black box, so that another light except transmitter's light can be eliminated.



Figure 4.1: Transceiver

4.2 Throughput

For the throughput, the system sends the data using the data rate of 115200, in order to achieve the maximum data rate of the standard with an OOK modulation, which is 100 kbps. The expected result of the test is whether the system can send data at the desired rate. Figure 4.2 shows the result of data transmission using a data rate of 115200. It is conducted at the distance of 10 cm. According to the results, only one unwanted character appears in the receiver serial terminal, so it is considered that the system can send the data in the maximum data rate.

4.3 BER

The test is conducted inside the controlled area, with the fixed distance of 10 cm. The summary of BER test is shown in Fig. 4.3.

In Fig. 4.3, S1 is a data sequence contains (2^1) , S2 is a data sequence contains $(2^1 2^2)$, and so on, until S30 is a data sequence contains $(2^1 2^2 \dots 2^{29} 2^{30})$. Every sequence is repeatedly sent 10 times. S1, S2, and S3 are not seen in Fig. 4.3 because it has no bit error. The highest bit error is produced in S30, which is 10 in repetition 5. The length of the sequence in S30 is 185 characters, which are equal to 185 bytes. In term of bits, it is 1480 bits long, so the BER of S30 is 6.7610^{-3} . On average, S8 has the highest BER, which is 0.773, as shown in Fig. 4.4. The reason why S30
This material is reserved for educational use only, not allowed for commercial use.

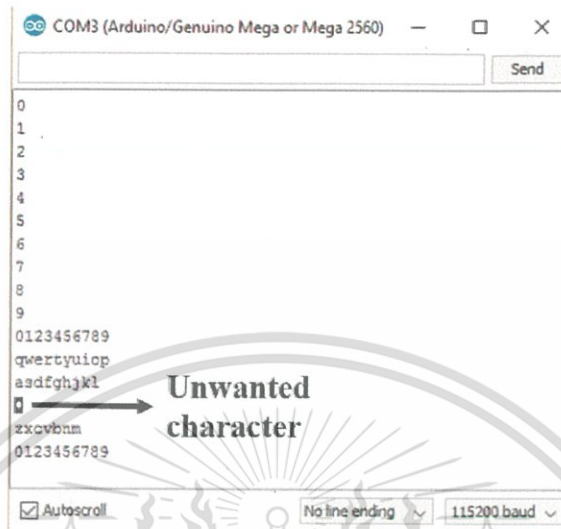

Figure 4.2: The result of data transmission with certain data rate

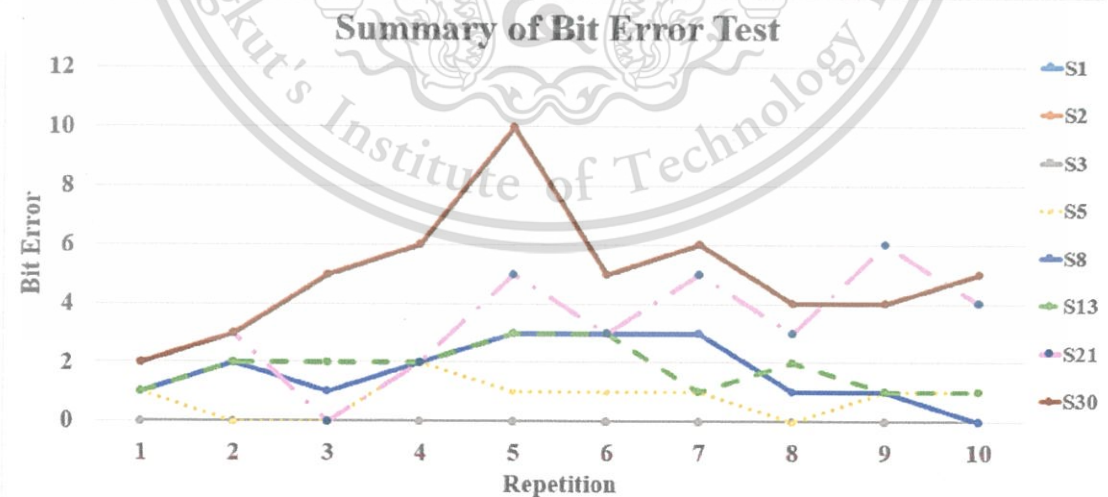

Figure 4.3: Summary of BER test

This material is reserved for educational use only, not allowed for commercial use.

Forbidden to modify the content, and cite the document when use.

has the highest BER is because the data format used to send the data, which is shown in Fig. 4.6a. S30 contains numbers from 2^1 to 2^{30} and in each number has a missing bit, e.g. 2 (00000010) becomes 0 (00000000), so it will increase the probability to have a higher bit error rather than S1.

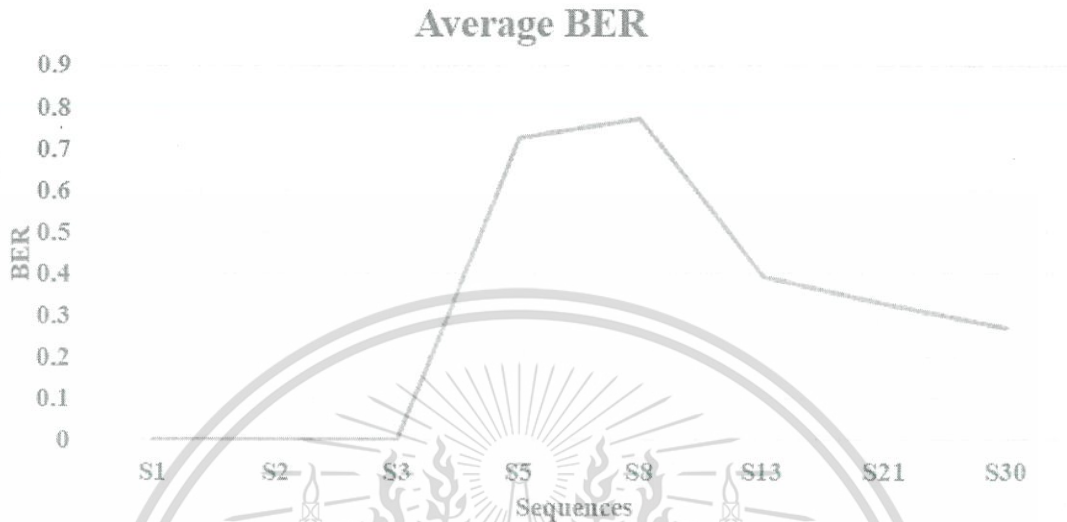

Figure 4.4: Average of BER

Figure 4.5 shows the BER test after changing the data format. It is shown that there is no missing bit from S1 to S30. The former data format is shown in Fig. 4.6a and latter data format is shown in Fig. 4.6b. The data format is changed because every time the enter character is used in the data format, the data after the enter character cannot be received correctly due to the missing bit occurs in every number. The new result shows that there is no bit error. The procedure is as same as the former BER test using prior data format.

```

2 4
2 4 8
2 4 8 16
2 4 8 16 32
2 4 8 16 32 64
2 4 8 16 32 64 128
2 4 8 16 32 64 128 256
2 4 8 16 32 64 128 256 512
2 4 8 16 32 64 128 256 512 1024
2 4 8 16 32 64 128 256 512 1024 2048
2 4 8 16 32 64 128 256 512 1024 2048 4096
2 4 8 16 32 64 128 256 512 1024 2048 4096 8192
2 4 8 16 32 64 128 256 512 1024 2048 4096 8192 16384
2 4 8 16 32 64 128 256 512 1024 2048 4096 8192 16384 32768
2 4 8 16 32 64 128 256 512 1024 2048 4096 8192 16384 32768 65536
2 4 8 16 32 64 128 256 512 1024 2048 4096 8192 16384 32768 65536 131072
2 4 8 16 32 64 128 256 512 1024 2048 4096 8192 16384 32768 65536 131072 262144
2 4 8 16 32 64 128 256 512 1024 2048 4096 8192 16384 32768 65536 131072 262144 524288
2 4 8 16 32 64 128 256 512 1024 2048 4096 8192 16384 32768 65536 131072 262144 524288 1048576
2 4 8 16 32 64 128 256 512 1024 2048 4096 8192 16384 32768 65536 131072 262144 524288 1048576 2097152
2 4 8 16 32 64 128 256 512 1024 2048 4096 8192 16384 32768 65536 131072 262144 524288 1048576 2097152 4194304
2 4 8 16 32 64 128 256 512 1024 2048 4096 8192 16384 32768 65536 131072 262144 524288 1048576 2097152 4194304 8388608
2 4 8 16 32 64 128 256 512 1024 2048 4096 8192 16384 32768 65536 131072 262144 524288 1048576 2097152 4194304 8388608 16777216
2 4 8 16 32 64 128 256 512 1024 2048 4096 8192 16384 32768 65536 131072 262144 524288 1048576 2097152 4194304 8388608 16777216 33554432
2 4 8 16 32 64 128 256 512 1024 2048 4096 8192 16384 32768 65536 131072 262144 524288 1048576 2097152 4194304 8388608 16777216 33554432 67108864
2 4 8 16 32 64 128 256 512 1024 2048 4096 8192 16384 32768 65536 131072 262144 524288 1048576 2097152 4194304 8388608 16777216 33554432 67108864 134217728

```

Figure 4.5: BER result

The relationship between BER and distance is shown in Fig. 4.7 to 4.14. Figure 4.7 shows the relationship between BER and distance using S1 sequence, containing only 1 byte, which is 2.



Figure 4.6: Data format

From the distance of 10 cm to 50 cm, the BER result in each repetition is 0, it means there is no missing bit or a bit lost in the transmission. Then, from the distance of 60 cm to 80 cm, it is shown that there is a bit error in each sequence. The error comes from the first byte of the data. It should be 2 (00000010 in binary), but the result is 0 (00000000 in binary). In that range of distance, it always has a missing bit in the first byte. The rest bytes are matched with the reference.

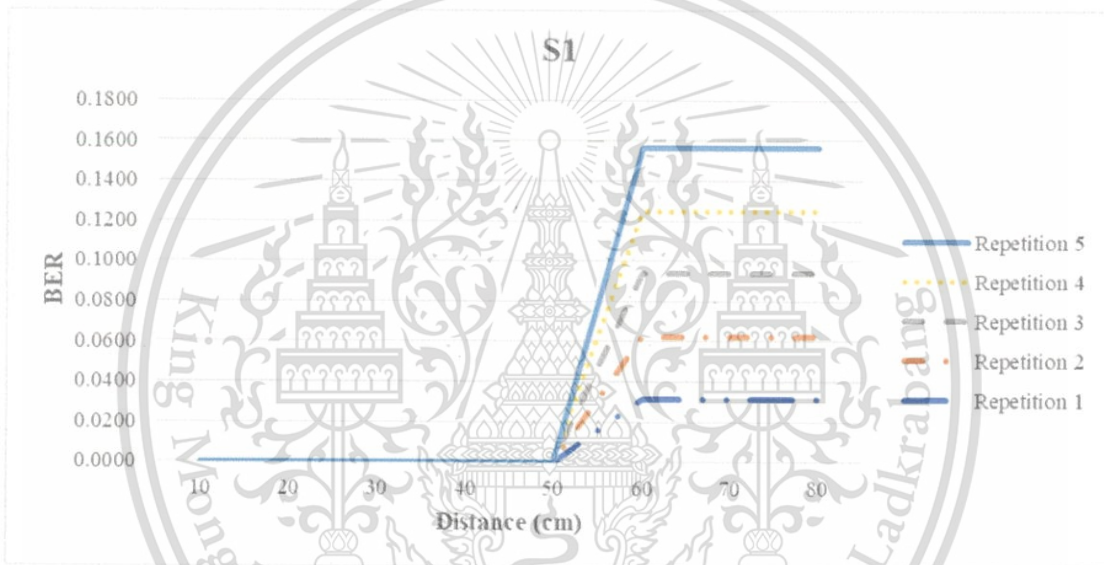

Figure 4.7: BER result S1 varied in distance

Figure 4.8 shows the relationship using S2 sequence containing 2 4. In repetition 1 and 2, the bit error is starting to occur at the distance of 70 cm. In repetition 3 until 5, the bit error is starting to occur at the distance of 60 cm. The error source is similar to the test using S1 sequence, which comes from the first byte of the data. It should be 2 (00000010 in binary), but the result is 0 (00000000 in binary).

Figure 4.9 shows the relationship using S3 sequence containing 2 4 8. In repetition 1 and 2, the bit error is starting to occur at the distance of 70 cm. In repetition 3 and 4, the bit error is starting to occur at the distance of 60 cm. In repetition 5, the bit error is starting to occur at the distance of 50 cm. The error source comes from the first byte of the data. It should be 2 (00000010 in binary), but the result is 0 (00000000 in binary).

This Figure 4.10 shows the relationship using S5 sequence containing 2 4 8 16 32. In all repe-

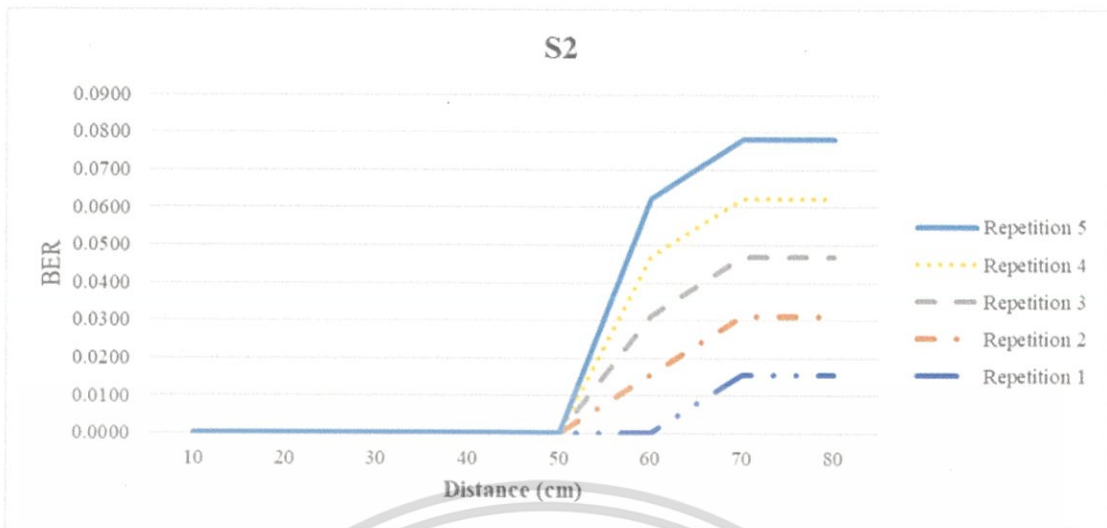

Figure 4.8: BER result S2 varied in distance

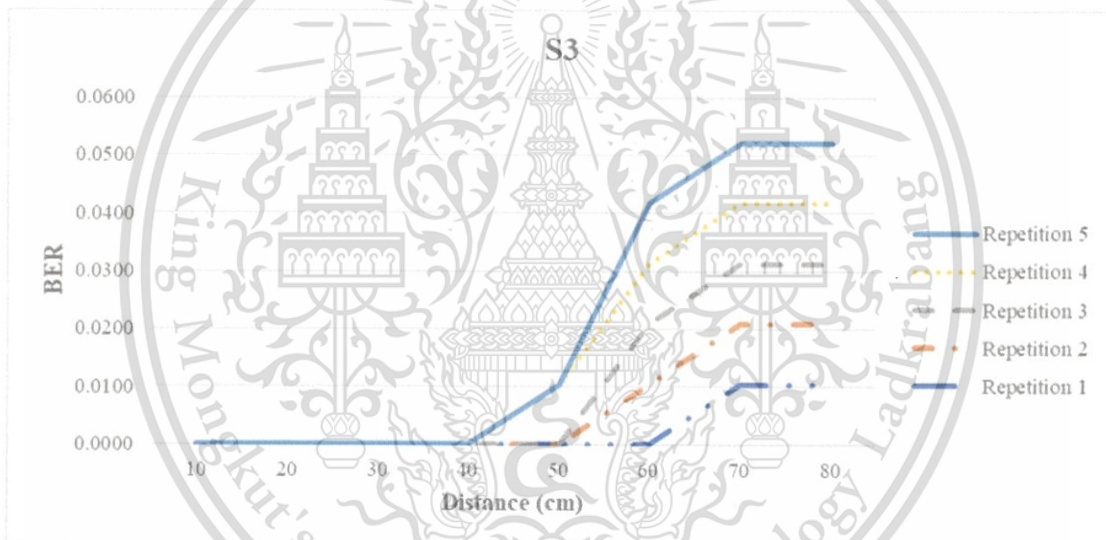

Figure 4.9: BER result S3 varied in distance

tion, the bit error is starting to occur at the distance of 60 cm. The error source comes from the first byte of the data. It should be 2 (00000010 in binary), but the result is 0 (00000000 in binary).

Figure 4.11 shows the relationship using S8 sequence containing 2 4 8 16 32 64 128 256. In repetition 2, the bit error is starting to occur at the distance of 70 cm. The rest repetitions, the bit error is starting to occur at the distance of 60 cm. The error source comes from the first byte of the data. It should be 2 (00000010 in binary), but the result is 0 (00000000 in binary).

Figure 4.12 shows the relationship using S13 sequence containing 2 4 8 16 32 64 128 256 512 1024 2048 4096 8192. In all repetition, the bit error is starting to occur at the distance of 60 cm. The error source comes from the first byte of the data. It should be 2 (00000010 in binary),

This material is reserved for educational use only, not allowed for commercial use.

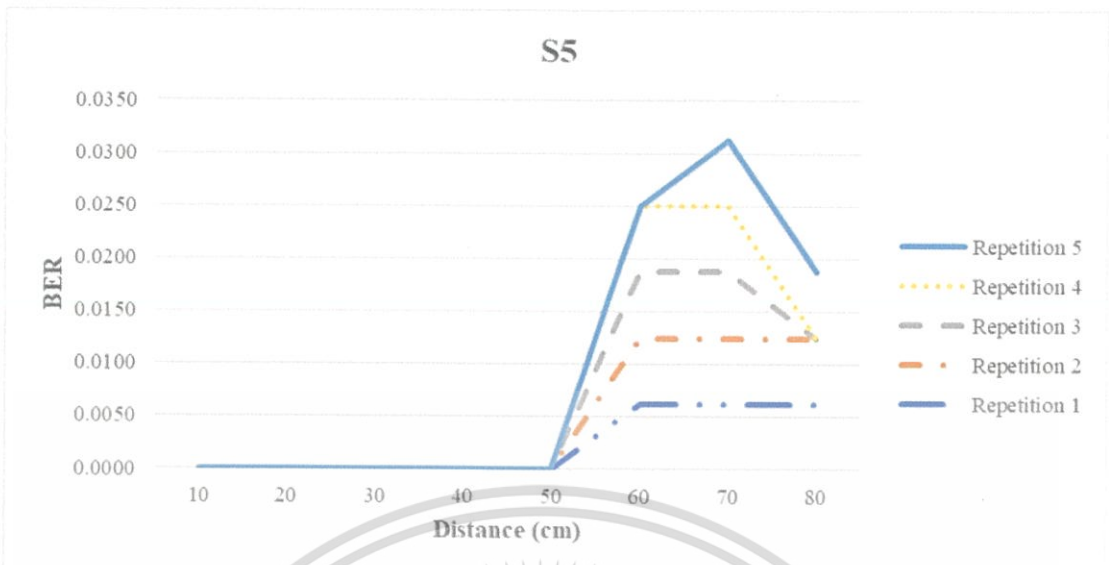

Figure 4.10: BER result S5 varied in distance

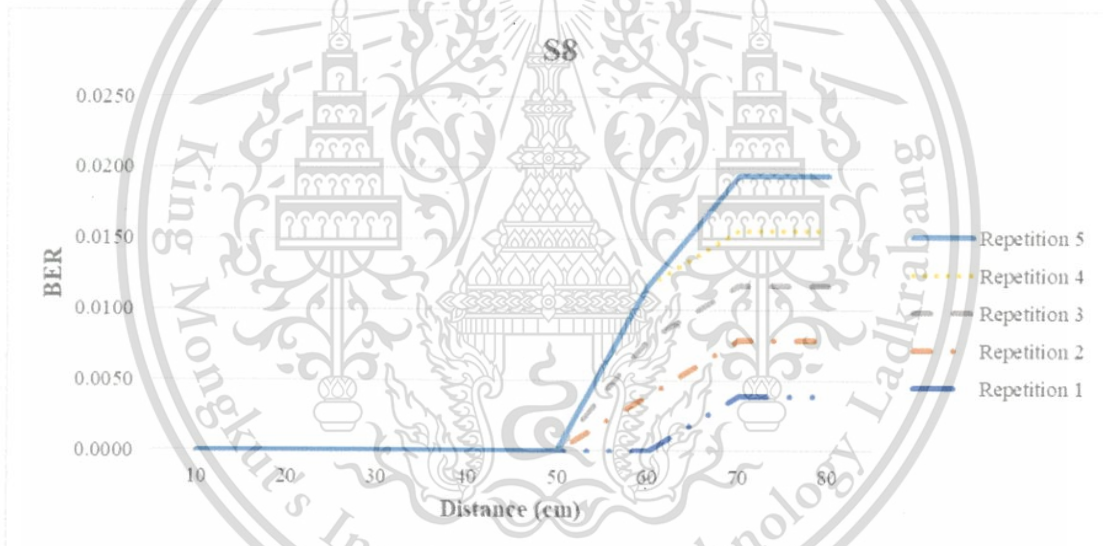

Figure 4.11: BER result S8 varied in distance

but the result is 0 (00000000 in binary).

Figure 4.13 shows the relationship using S21 sequence containing 2 4 8 16 32 64 128 256 512 1024 2048 4096 8192 16384 32768 65536 131072 262144 524288 1048576 2097152. In repetition 1, 3, and 5, the bit error is starting to occur at the distance of 50 cm. In repetition 2 and 4, it is starting to occur at the distance of 60 cm. The error source comes from the first byte of the data. It should be 2 (00000010 in binary), but the result is 0 (00000000 in binary).

Figure 4.14 shows the relationship using S30 sequence containing 2 4 8 16 32 64 128 256 512 1024 2048 4096 8192 16384 32768 65536 131072 262144 524288 1048576

This material is reserved for educational use only, not allowed for commercial use.

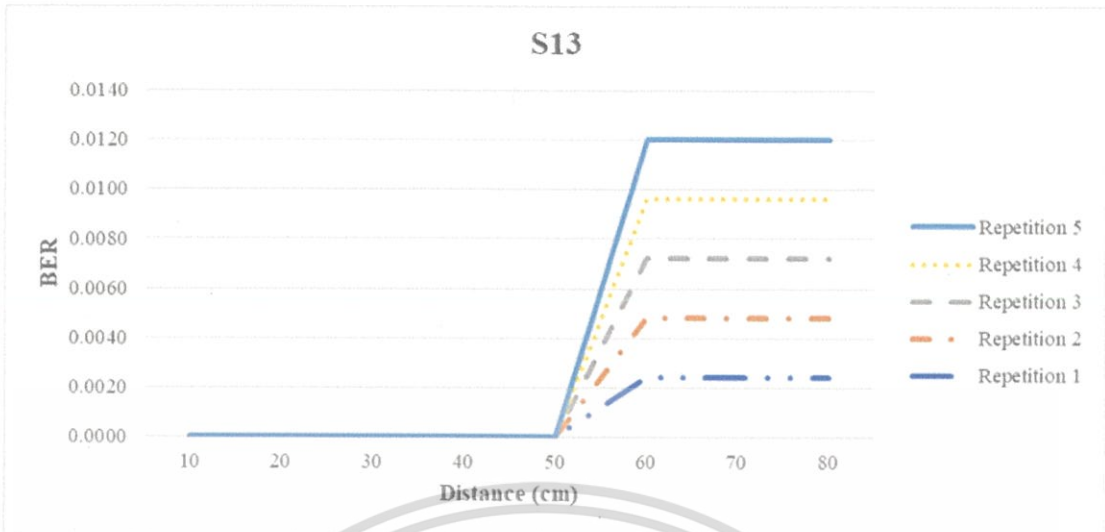

Figure 4.12: BER result S13 varied in distance

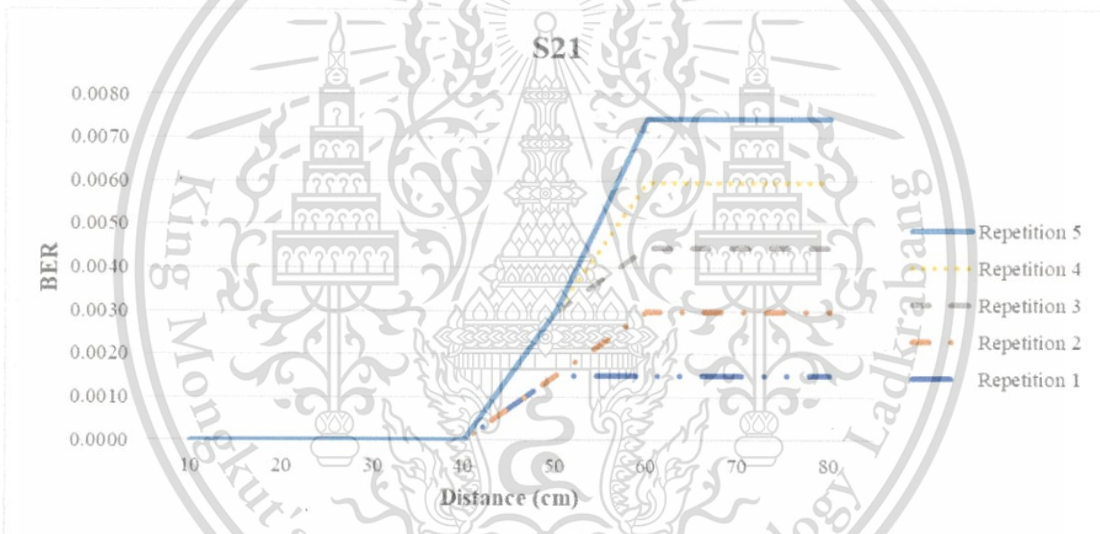

Figure 4.13: BER result S21 varied in distance

2097152 4194304 8388608 16777216 33554432 67108864 134217728 268435456 536870912 1073741824. In repetition 1 and 2, the bit error is starting to occur at the distance of 60 cm. In repetition 3 to 5, it is starting to occur at the distance of 50 cm. The error source comes from the first byte of the data. It should be 2 (00000010 in binary), but the result is 0 (00000000 in binary).

The summary of the relationship between BER and distance is shown in Fig. 4.15. It is shown that the biggest BER is in the S1 and the lowest BER is in the S30. The BER value is not zero when the distance is above 40 cm. The source of bit error in every data sequence comes from the first byte of the data, because there is a missing bit in it. In practical, the system can send data in any length.

This material is reserved for educational use only, not allowed for commercial use.

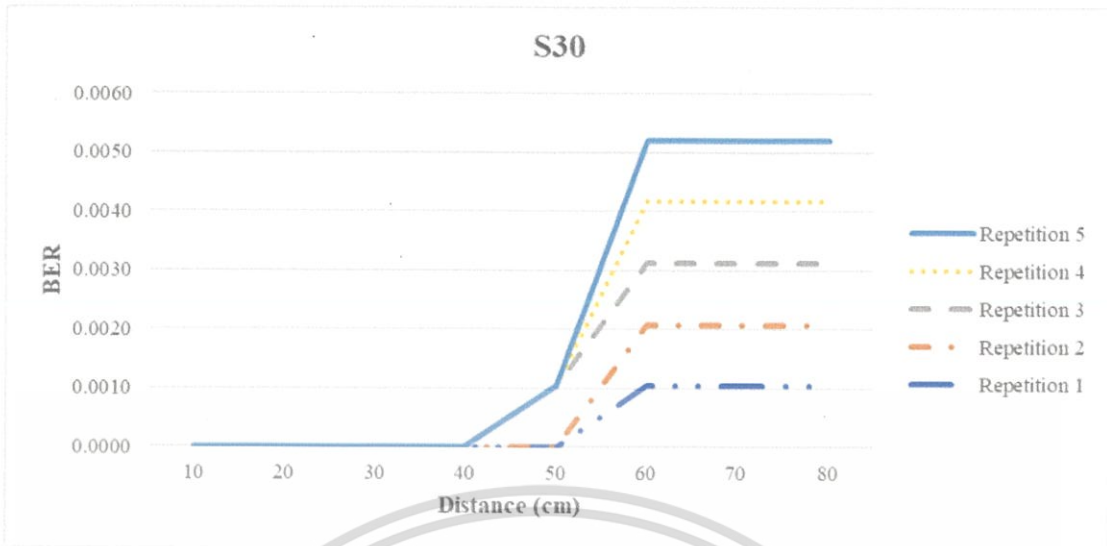

Figure 4.14: BER result S30 varied in distance

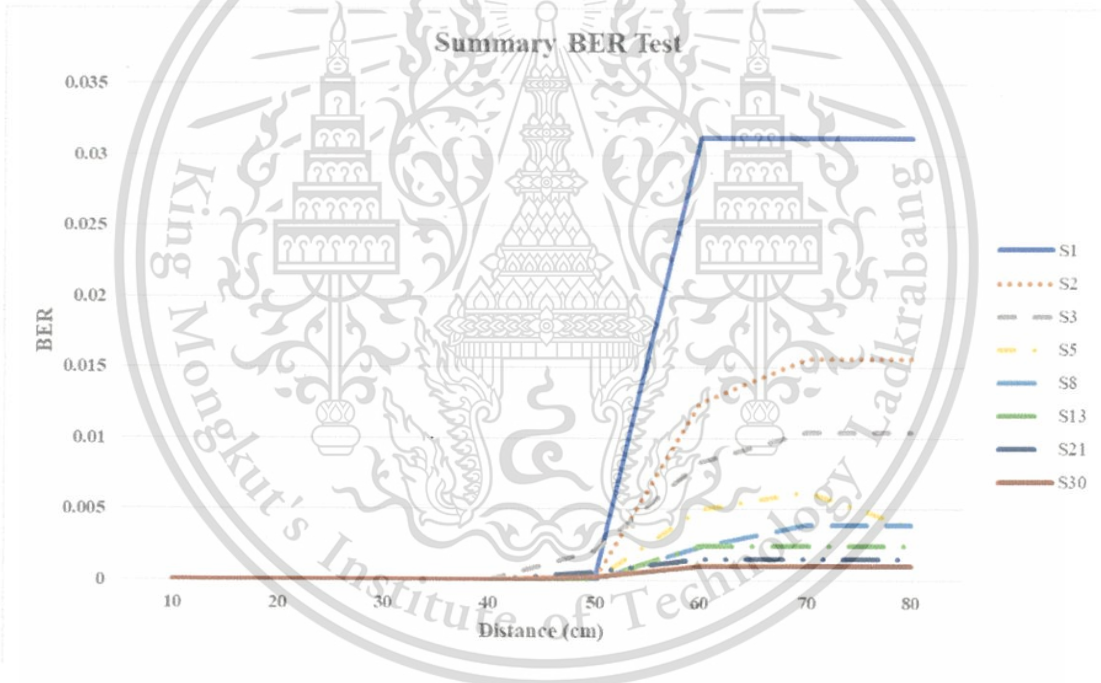

Figure 4.15: Summary of relationship between BER and distance

4.4 Distance

The results of a performance test based on the distance are shown in Fig. 4.16, Fig. 4.17, and Fig. 4.18. Figure 4.16 shows the result of successfully received data from the distance of 10 cm to the distance of 30 cm, which all values are exactly the same with the data from the transmitter.

Figure 4.17 shows the result of received data in the distance from 40 cm to 80 cm. It is

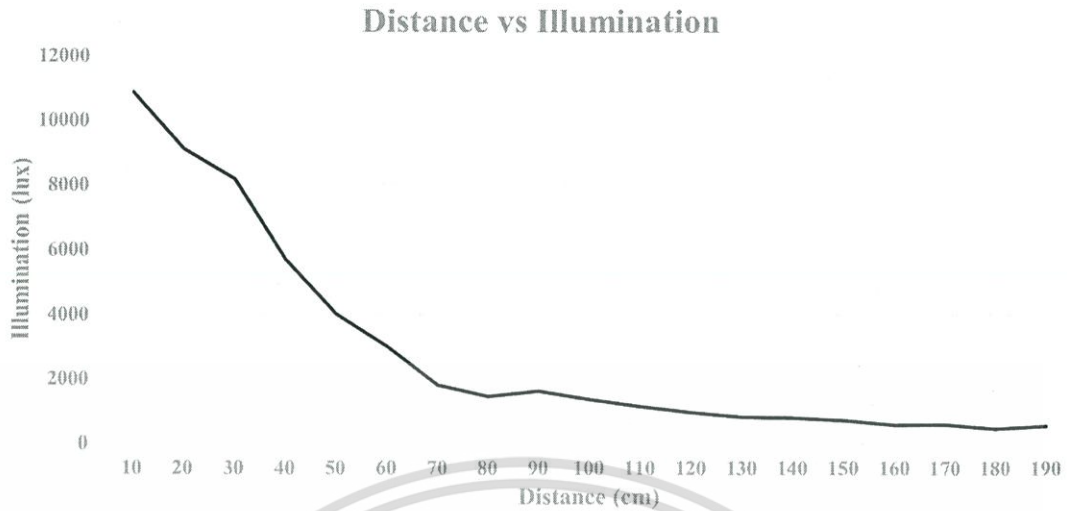

Figure 4.19: Distance vs illumination

cm. In the distance of 80 cm, which is the maximum distance of the system can send the data, the optical power is 40.37 mW. Based on that figure, it can be considered that the system needs only a low optical power to do a data transmission. If we compare Fig. 4.20 with Fig. 4.19, it is shown that the change of optical power according to the distance is linear with the change of illumination according to the distance. This relationship is also shown in Eq. 4.1. $P_{Optical}$ is the optical power with the unit of Watt, I is the illumination with the unit of Lux, A is the receiving area with the unit of m^2 , and η is the efficacy value of the sensor.

$$P_{Optical} = \frac{IA}{\eta} \quad (4.1)$$

4.5 Types of file

The result of the first test data transmission is shown in Fig. 4.21. Figure 4.21a shows the reference data in the transmitter and Fig. 4.21b shows the result of data transmission. Those figures show there is a difference in the number of bytes in the receiver and the number of bytes in the transmitter. In the receiver side, the number of bytes is 1272, while on the transmitter side, the number of bytes is 4804. That problem is caused by the mechanism to send data. The transmitter sends the data without separation, which means the transmitter does not care about whether the data are in a small size or a large size. Then, that mechanism is changed by splitting the data into several parts, each part containing a maximum of 100 bytes, due to the maximum serial buffer of the microcontroller which is 64 bytes. The result after mechanism changes is shown in the next paragraph.

This material is reserved for educational use only, not allowed for commercial use.

Distance vs Optical Power

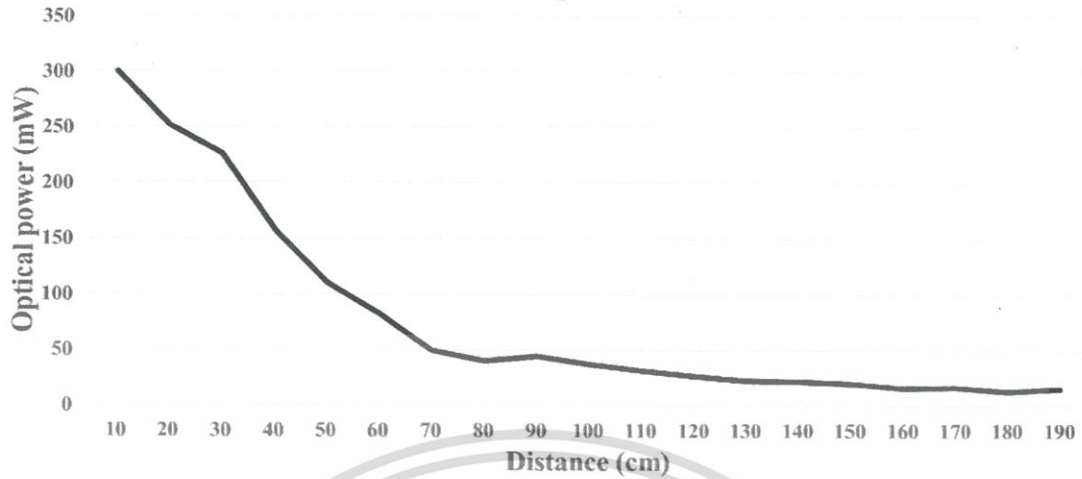

Figure 4.20: Distance vs optical power

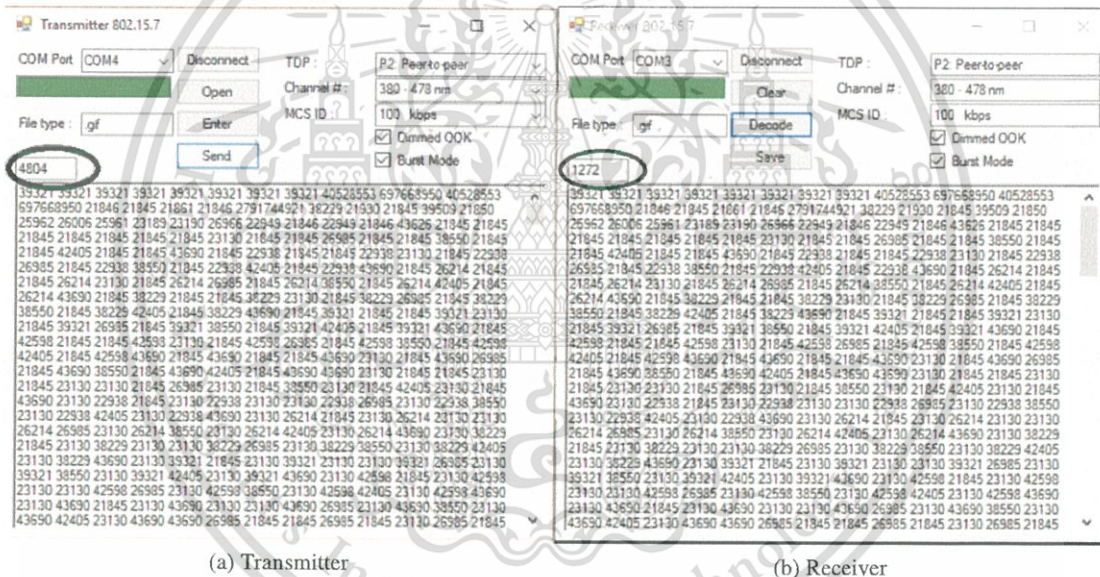

Figure 4.21: Result of data transmission

4.5.1 Audio file

The result of audio file transmission is shown in Fig. 4.22. The blue bar is the number of data received by the receiver, the orange bar represents the number of correct data received by the receiver after compared with the reference file, and the grey bar represents the reference file. The number of bytes from the reference file along with the header is 11004 bytes. It is shown in Fig. 4.22 that only repetition 2 that has a big difference between the number of data received and the number of correct data received. All files can be opened through the media player even though all of them have noise.

This material is reserved for educational use only, not allowed for commercial use.

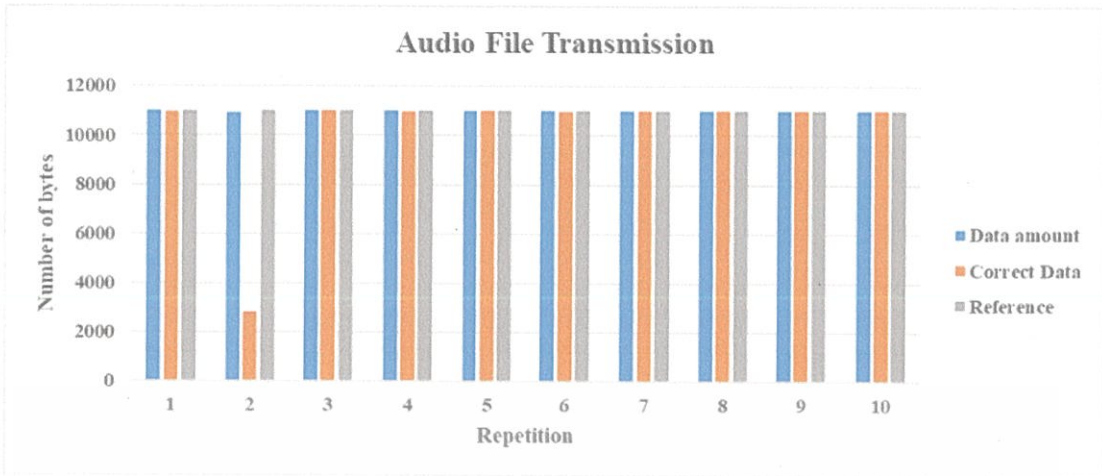

Figure 4.22: Result of audio file transmission

Fig. A.1 to A.10 show the results of audio file transmission after compare with the reference file. All of them contain noise and the least noise is contained in repetition 3.

4.5.2 Image file

The result of image file transmission is shown in Fig. 4.23 and Fig. 4.24. The number of bytes from the GIF reference file and PNG reference file are 4803 bytes and 6725 bytes, respectively. Figure 4.23 shows that all received correct data in every repetition, but only the file received in the repetition 2, 6, and 8 that similar to the reference file.

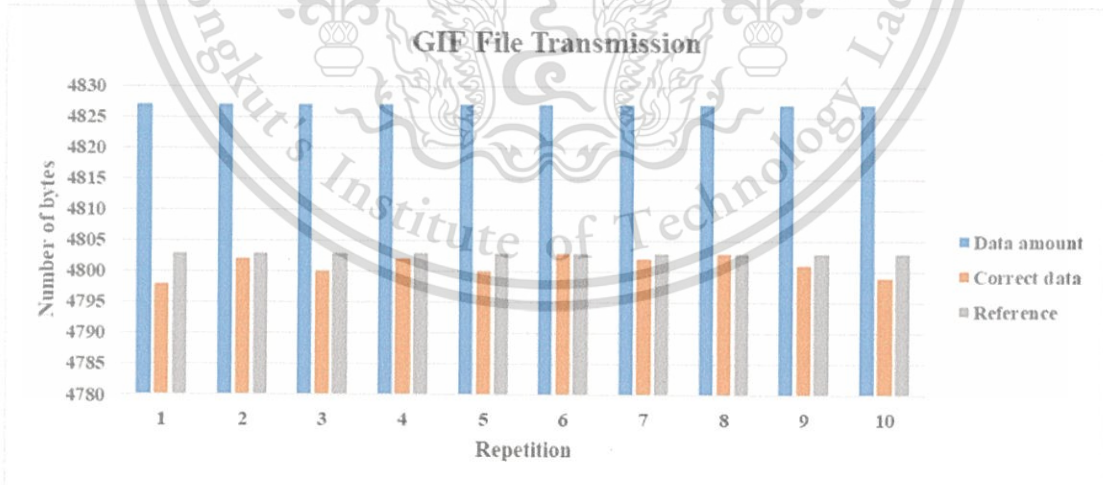

Figure 4.23: Result of GIF file transmission

The comparison results for the GIF image in every repetition are shown in Fig. B.1 to B.10. But, for PNG file transmission, all files are noisy and no one that similar to the reference file, as shown in Fig. B.11 to B.20. All repetitions except repetition 10 have similar amount between the



Figure 4.24: Result of PNG file transmission

received correct data and the reference file, but the final image is not as same as the reference file. Although the received correct data has the same amount with the reference file, but it is not a guarantee that the final result will be the same as the reference file.

4.5.3 Document file

The results of document file consists of the result of Excel file, Word file, PDF file, Powerpoint file, and Text file. Each file will be explained in the separate section.

4.5.3.1 Excel file

Figure 4.25 shows the result of Excel file transmission in each repetition. Based on the size comparison, all repetitions except repetition 8 show that the size of received correct data is similar to the size of the reference file. But, if it is analyzed based on the file, the result will be different.

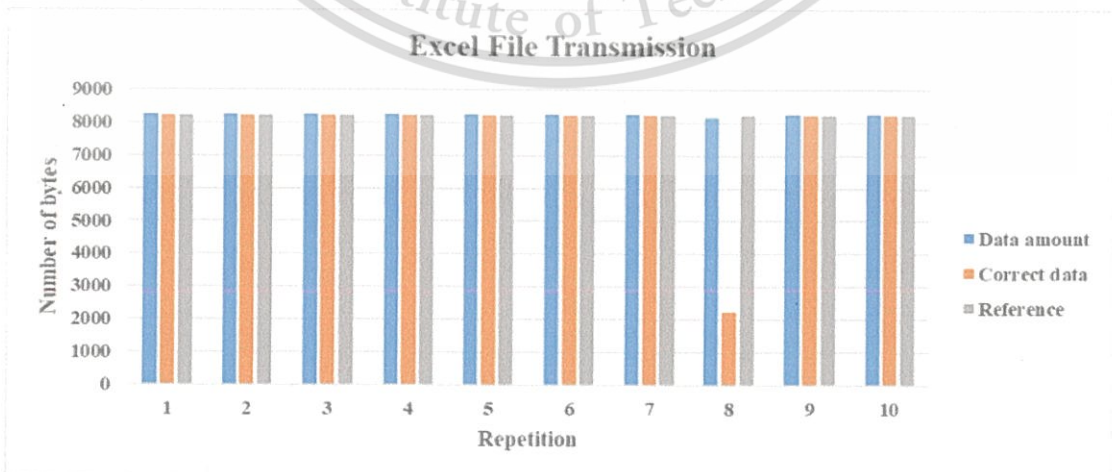

Figure 4.25: Result of MS Excel file transmission

This material is reserved for educational use only, not allowed for commercial use.

Forbidden to modify the content, and cite the document when use.

The results of Excel file transmission are shown in Fig. C.1 to C.20. Only the file in the repetition 2 and 4 that can be opened after through the recovery process. Other files cannot be opened, even after through the recovery process. Those files that can be opened are exactly the same with the reference file.

4.5.3.2 Word file

Figure 4.26 shows the result of Word file transmission in each repetition based on the size. All repetitions except repetition 3 show that the size of received correct data is similar to the size of the reference file. But, the result based on the file is different with the result based on the size comparison.

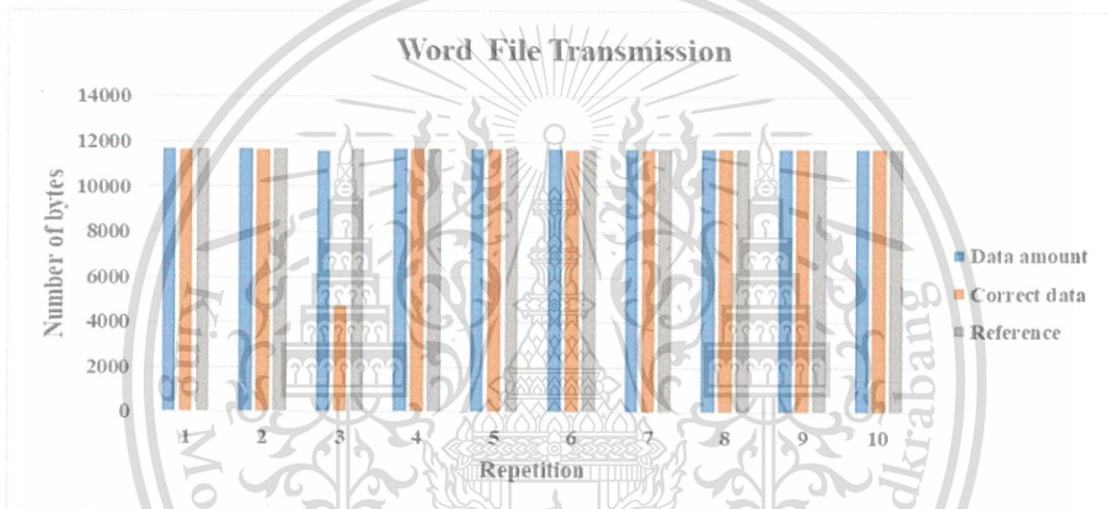

Figure 4.26: Result of MS Word file transmission

The results of Word file transmission are shown in Fig. C.21 to C.40. From those figures, the file in the repetition 4, 6, 8, and 9 that can be opened after through the recovery process. Those files that can be opened are exactly the same with the reference file.

4.5.3.3 PDF file

Figure 4.27 shows the result of PDF file transmission in all repetition based on the size. All repetitions show that no size of received correct data that similar to the size of reference file. The result based on the file is different from the result based on the size.

The results of PDF file transmission are shown in Fig. C.41 to C.50. The file in the repetition 1, 3, 4, 5, 6, 7, and 10 that can be opened after through the recovery process. But, only the file in the repetition 4 and 6 that are exactly the same with the reference file. The file in the repetition 10 is almost similar to the reference file because the letter "k" is missing from the file.

This material is reserved for educational use only, not allowed for commercial use.

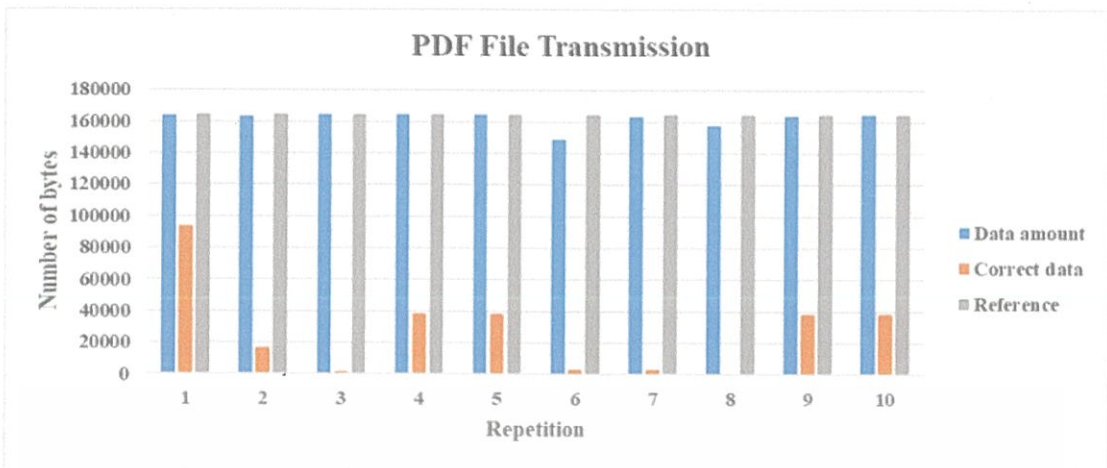

Figure 4.27: Result of PDF file transmission

4.5.3.4 Powerpoint file

Figure 4.28 shows the result of Powerpoint file transmission in all repetition based on the size. All repetitions except repetition 7, 8, and 9 have the similar size between the size of received correct data and the size of the reference file. But, the result based on the file is different from the result based on the size.

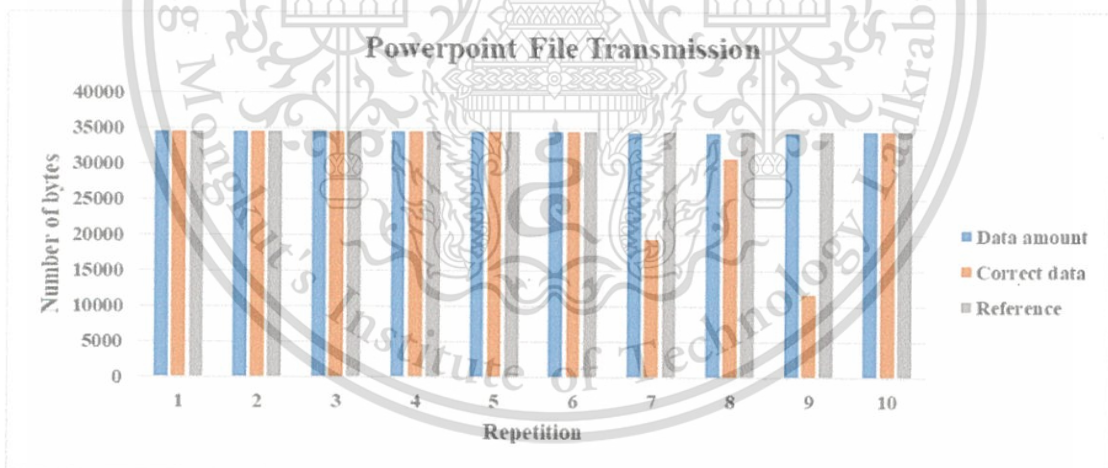

Figure 4.28: Result of MS PowerPoint file transmission

The results of Powerpoint file transmission are shown in Fig. C.51 to C.70. From those figures, the file in the repetition 2, 3, 4, 5, 6, and 8 that can be opened after through the recovery process, even though only the file in the repetition 4, 5, and 6 that exactly the same with the reference file.

This material is reserved for educational use only, not allowed for commercial use.

Forbidden to modify the content, and cite the document when use.

4.5.3.5 Text file

Figure 4.29 shows the result of Text file transmission in all repetitions based on the size. All repetitions show that the size of received correct data is exactly the same with the size of the reference file.

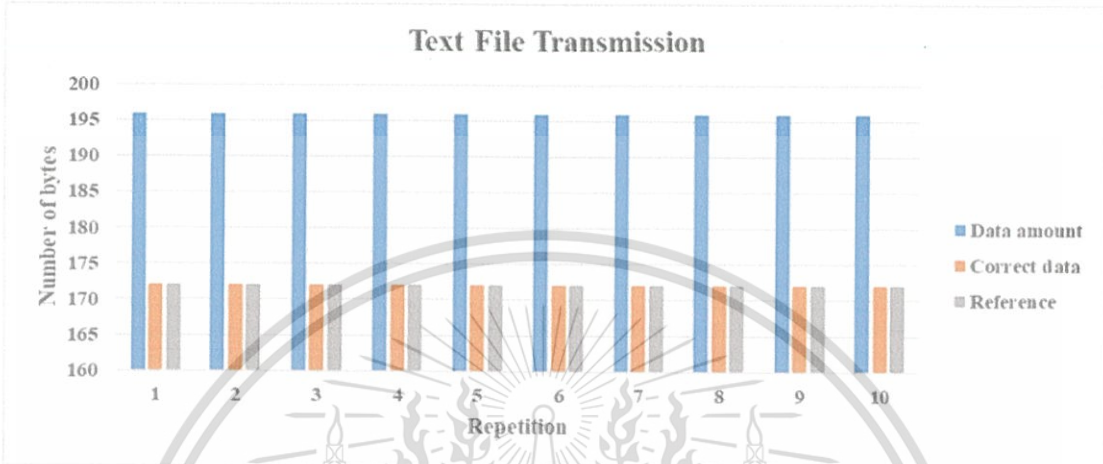

Figure 4.29: Result of Text file transmission

The results of Text file transmission are shown in Fig. C.71 to C.80. All files in the repetition can be opened and they are exactly the same with the reference file.

The system is also checked to know the maximum file size of received data without any data lost in a single transmission. From the observation by sending a text file, the maximum file size is 1.20 kilo bytes containing numbers from 1 to 325. When the system wants to send a bigger file than 1.20 kilo bytes, there are lots of missing data. The summary of the types of file test is shown in Table 4.1. The plain cell indicates the file is in the good condition, means that can be opened normally without any recovery or noise for the audio file. While the gray cell indicates the file can be opened with a recovery or the file is noisy for the audio file. The black cell indicates the file cannot be completely opened. One of the reasons why other files cannot be opened completely is because there is/are a missing bit(s) during the transmission of each file due to the limitation of the serial buffer size of the microcontroller.

Table 4.1: Result of various types of file transmission

File type	Reference	Result									
		1	2	3	4	5	6	7	8	9	10
Audio (.mp3)	100%	99.80%	25.65%	99.91%	99.83%	99.89%	99.87%	99.95%	99.92%	99.90%	99.96%
Excel (.xlsx)	100%	99.98%	99.95%	99.96%	99.96%	99.99%	99.96%	99.93%	26.94%	99.82%	99.84%
Image (.gif)	100%	99.90%	99.98%	99.94%	99.98%	99.94%	100%	99.98%	100%	99.96%	99.92%
Image (.png)	100%	99.91%	99.97%	99.96%	99.97%	99.94%	99.97%	99.96%	99.93%	99.85%	28.46%
PDF (.pdf)	100%	56.99%	10.21%	1.22%	23.29%	23.29%	1.66%	2.05%	0.76%	23.24%	23.22%
Powerpoint (.pptx)	100%	99.99%	99.93%	99.99%	99.99%	99.99%	99.99%	56.30%	88.92%	34.04%	99.97%
Text (.txt)	100%	100%	100%	100%	100%	100%	100%	100%	100%	100%	100%
Word (.docx)	100%	99.91%	99.88%	40.16%	99.98%	99.95%	99.93%	99.90%	99.97%	99.97%	99.97%

CHAPTER 5

CONCLUSION AND FUTURE WORKS

The performance investigation of the VLC system based on the IEEE 802.15.7 PHY I has been conducted. It is performed based on four parameters, which are throughput, distance, bit error rate, and types of file. The system is composed of a pair of transceivers and the transceiver utilizes a LED as the transmitter source and a high-speed photodiode as the receiver. For the throughput, the system can send data with the data rate of 100 kbps with a presence of an unwanted character in a short distance. For the distance, the system can send data successfully without any missing bit at the maximum distance of 40 cm. For the range distance of 40 cm to 80 cm, the system can send data with a missing bit in the beginning of the bit sequence. For the distance of more than 80 cm, the system completely cannot send data. For the bit error rate, the biggest error rate is when the system send a short data (S1) in the range distance of 50 cm to 80 cm, and the lowest error rate is when the system send a long data (S30) in the same range distance. About the types of files, only the PNG image file cannot be opened successfully after being sent. The audio file can be open but it contains noise. The GIF file has a 30% probability of successfully transmitted. The Excel file, PDF file, Powerpoint file, and Word file have a probability to be successfully transmitted in a percentage of 20%, 70%, 60%, and 40%, respectively and all files should through a recovery process when the files wants to be opened. Only the Text file that has a 100% probability of successfully transmitted.

The future work for this research is to develop this system to be able to comply with the IEEE 802.15.7 standard, not only the PHY I but also the PHY II, because both physical layers has the same type of modulations, so no need to use different circuit design. Also, the system needs more test to make sure that it can comply with the IEEE 802.15.7 standard, especially for the data rate and another type of modulation, because this research is only done for the highest data rate of PHY I with an OOK modulation.

REFERENCES

- [1] Y. F. Luckyarno, P. Cherntanomwong, and R. Wijaya, "Posturometry data transmission using visible light communication," in *Proc. 2016 13th International Conference on Electrical Engineering/Electronics, Computer, Telecommunications and Information Technology (ECTI-CON)*, 2016, pp. 1–4.
- [2] Y. F. Luckyarno, P. Cherntanomwong, and C. Nuthong, "Real-time Vital Sign Transmission using VLC," *Proc. AUN/SEED-Net Regional Conference on Computer and Information Engineering (RCCIE 2016)*, 2016.
- [3] *Short-Range Wireless Optical Communication Using Visible Light*, IEEE Std. 802.15.7, 2011.
- [4] E. Sarbazi and M. Uysal, "PHY layer performance evaluation of the IEEE 802.15.7 visible light communication standard," *Proc. 2013 2nd International Workshop on Optical Wireless Communications (IWOW)*, pp. 35–39, 2013.
- [5] L. Klaver and M. Zuniga, "Shine: A Step Towards Distributed Multi-Hop Visible Light Communication," *Proc. 2015 12th International Conference on Mobile Ad Hoc and Sensor Systems (MASS)*, pp. 235–243, 2015.
- [6] F. Che, L. Wu, B. Hussain, X. Li, and C. P. Yue, "A Fully Integrated IEEE 802.15.7 Visible Light Communication Transmitter With On-Chip 8-W 85 % Efficiency Boost LED Driver," *Lightwave Technology*, vol. 34, no. 10, pp. 2419–2430, May 2016.
- [7] Y. Chen, Y. Su, D. Xue, and C. Dong, "Research on Performance of Visible Light Communication Based on LDPC Code," *Proc. 2015 5th International Conference on Instrumentation and Measurement, Computer, Communication and Control (IMCCC)*, pp. 1461–1465, 2015.
- [8] S. Li, C. Gong, and Z. Xu, "Visible light communication performance in weak illumination environment," *Proc. 2015 Opto-Electronics and Communications Conference (OECC)*, pp. 1–3, 2015.
- [9] Q. Han and H. Lu, "Performance Improvement of Visible Light Communication System Using Reed-Solomon Code," *Proc. 2015 IEEE 12th Intl. Conf. on Ubiquitous Intelligence and Computing and 2015 IEEE 12th Intl. Conf. on Autonomic and Trusted Computing and*
- This material is reserved for educational use only, not allowed for commercial use.

2015 IEEE 15th Intl. Conf. on Scalable Computing and Communications and Its Associated Workshops (UIC-ATC-ScalCom), pp. 822–825, 2015.

- [10] S. Arnon, J. Barry, G. Karagiannidis, R. Schober, and M. Uysal, *Advanced Optical Wireless Communications Systems*. Cambridge, UK: Cambridge University Press, 2012.
- [11] S. Rajagopal, R. D. Roberts, and S.-K. Lim, “IEEE 802.15.7 visible light communication: Modulation schemes dimming support,” *Communications Magazine, IEEE*, pp. 72–82, 2012.
- [12] S. Arnon, *Visible Light Communication*. Cambridge, UK: Cambridge University Press, 2015.
- [13] C.-X. Wang, F. Haider, X. Gao *et al.*, “Cellular architecture and key technologies for 5G wireless communications networks,” *IEEE Communications Magazine*, vol. 52, pp. 122–130, 2014.
- [14] S. Ayub, S. Kariyawasam, M. Honary, and B. Honary, “A practical approach of VLC architecture for smart city,” *Proc. Int. Conf. In Antennas and Propagation Conference (IAPC)*, pp. 106–111, 2013.
- [15] T. Yokotani, “Application and technical issues on Internet of Things,” *Proc. 2012 10th Int. Conf. In Optical Internet (COIN)*, pp. 67–68, 2012.
- [16] F. E. Schubert and J. K. Kim, “Solid-state light sources getting smart,” *Science* 308, pp. 1274–1278, 2005.
- [17] S. Arnon, “Optimised optical wireless car-to-traffic-light communication,” *IEEE Transactions on Emerging Telecommunications*, pp. 660–665, 2014.
- [18] S. J. Lee, J. K. Kwon, S.-Y. Jung, and Y. H. Kwon, “Evaluation of visible light communication channel delay profiles for automotive applications,” *EURASIP Journal on Wireless Communications and Networking*, pp. 1–8, 2012.
- [19] S.-Y. Lee, J.-K. Lee, D.-K. Park, and S.-H. Park, “Development of automotive multimedia system using visible light communications,” *In Multimedia and Ubiquitous Engineering*, pp. 219–225, 2014.
- [20] S.-H. Yu, O. Shih, H.-M. Tsai, and R. D. Roberts, “Smart automotive lighting for vehicle safety,” *IEEE Communications Magazine*, pp. 50–59, 2013.

This material is reserved for educational use only, not allowed for commercial use.

- [21] S.-H. You, S.-H. Chang, H.-M. Lin, and H.-M. Tsai, "Visible light communications for scooter safety," *Proc. 11th Annual Intl. Conf. on Mobile Systems, Applications, and Services*, pp. 509–510, 2003.
- [22] Z. Ghassemlooy, W. Popola, and S. Rajbhandari, *Optical Wireless Communications: System and Channel Modelling with MATLAB*. Florida, USA: CRC Press, 2013.
- [23] A. Cailean, B. Cagneau, L. Chassagne *et al.*, "Visible light communications: Application to cooperation between vehicles and road infrastructures," *Proc. IEEE In Intelligent Vehicles Symposium (IV)*, pp. 1055–1059, 2012.
- [24] R. Murai, T. Sakai, H. Kawano *et al.*, "A novel visible light communication system for enhanced control of autonomous delivery robots in a hospital," *Proc. 2012 IEEE/SICE Int. Symposium In System Integration (SII)*, pp. 510–516, 2012.
- [25] S. S. Torkestani, N. Barbot, S. Sahuguede, A. Julien-Vergonjanne, and J.-P. Cances, "Performance and transmission power bound analysis for optical wireless based mobile healthcare applications," *Proc. 22nd International Symposium In Personal Indoor and Mobile Radio Communications (PIMRC)*, pp. 2198–2202, 2011.
- [26] Y. Y. Tan, S.-J. Jung, and W.-Y. Chung, "Real time biomedical signal transmission of mixed ecg signal and patient information using visible light communication," *Proc. 35th Annual International Conference of the IEEE In Engineering in Medicine and Biology Society (EMBC)*, pp. 4791–4794, 2013.
- [27] N. O. Tippenhauer, D. Giustiniano, and S. Mangold, "Toys communicating with LEDs: Enabling toy cars interaction," *Proc. IEEE In Consumer Communications and Networking Conference (CCNC)*, pp. 48–49, 2012.
- [28] S. Schmid, G. Corbellini, S. Mangold, and T. R. Gross, "LED-to-LED visible light communication networks," *Proc. 14th ACM Intl. Symposium on Mobile ad hoc Networking and Computing*, pp. 1–10, 2013.
- [29] R. D. Roberts, "Undersampled frequency shift ON-OFF keying (UFSOOK) for camera communications (CamCom)," *Proc. IEEE In Wireless and Optical Communication Conference (WOCC)*, pp. 645–648, 2013.
- [30] J. E. McNamara, *Technical Aspects of Data Communication*. Massachussets, USA: Butterworth-Heinemann, 1988.

- [31] J. O. Hamblen, T. S. Hall, and M. D. Furman, *Rapid Prototyping of Digital System*. New York, USA: Springer, 2008.
- [32] Arduino. (2017, March) Arduino mega2560. [Online]. Available: <http://www.arduino.cc/en/Main/ArduinoBoardMega2560>
- [33] W. Chantharasena, "Study on Indoor Localization System Using Visible Light Communication," Bangkok, Thailand, 2015.
- [34] J. Fraden, *Handbook of Modern Sensors: Physics, Designs, and Applications*, 3rd ed. New York, USA: Springer-Verlag, 2004.
- [35] (SFH203P) Silicon PIN Photodiode with Very Short Switching Time, Osram, 12 2003.
- [36] (TSV992AIDT) Rail-to-rail input/output 20 MHz GBP operational amplifiers, ST Microelectronics, 11 2015.
- [37] M. Strobl, T. Waas, M. Moolenaar, A. Schingale, and N. Balbierer, "Bit Error Rate Testing Serial Communication Equipment using Pseudo-Random Bit Sequences," presented at the 3rd IEEE Germany Student Conference (IEEE GSC 2012), 2012.



This material is reserved for educational use only, not allowed for commercial use.

Forbidden to modify the content, and cite the document when use.

APPENDIX A

AUDIO FILE RESULTS

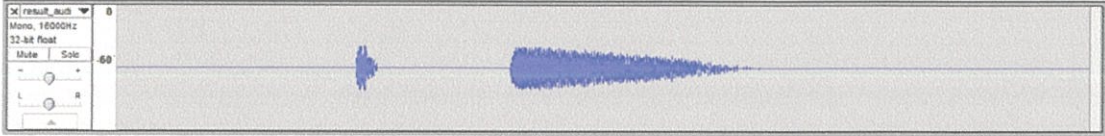

Figure A.1: Result of audio file transmission in repetition 1

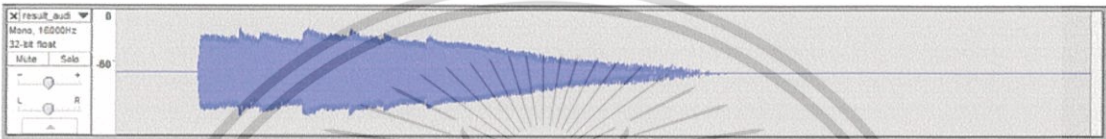

Figure A.2: Result of audio file transmission in repetition 2



Figure A.3: Result of audio file transmission in repetition 3



Figure A.4: Result of audio file transmission in repetition 4



Figure A.5: Result of audio file transmission in repetition 5

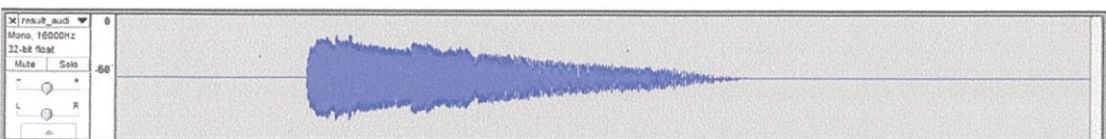

Figure A.6: Result of audio file transmission in repetition 6

This material is reserved for educational use only, not allowed for commercial use.

Forbidden to modify the content, and cite the document when use.

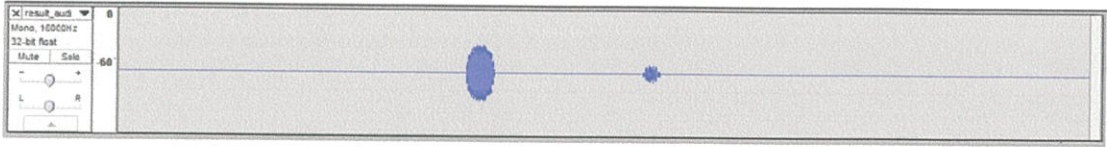

Figure A.7: Result of audio file transmission in repetition 7

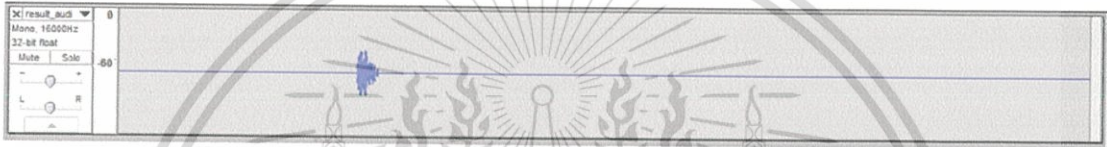

Figure A.8: Result of audio file transmission in repetition 8

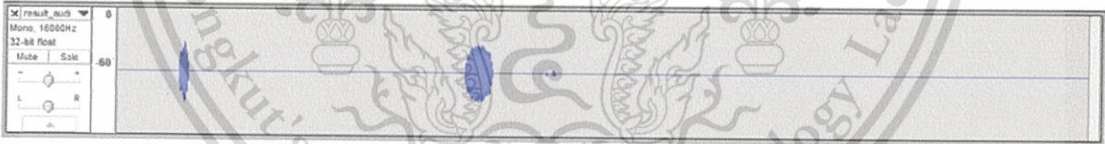

Figure A.9: Result of audio file transmission in repetition 9

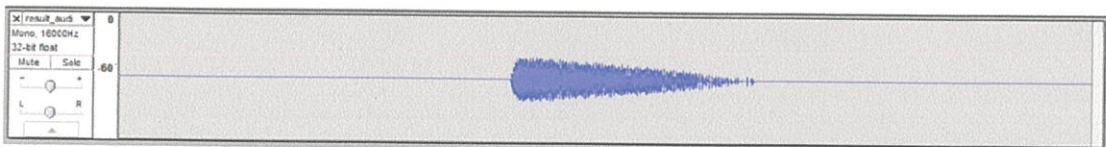

Figure A.10: Result of audio file transmission in repetition 10

This material is reserved for educational use only, not allowed for commercial use.

Forbidden to modify the content, and cite the document when use.

APPENDIX B

IMAGE FILE RESULTS



(a) Received image

(b) Reference image

Figure B.1: GIF file transmission result in repetition 1



(a) Received image

(b) Reference image

Figure B.2: GIF file transmission result in repetition 2



(a) Received image

(b) Reference image

Figure B.3: GIF file transmission result in repetition 3

This material is reserved for educational use only, not allowed for commercial use.

Forbidden to modify the content, and cite the document when use.

(a) Received image

(b) Reference image

Figure B.4: GIF file transmission result in repetition 4

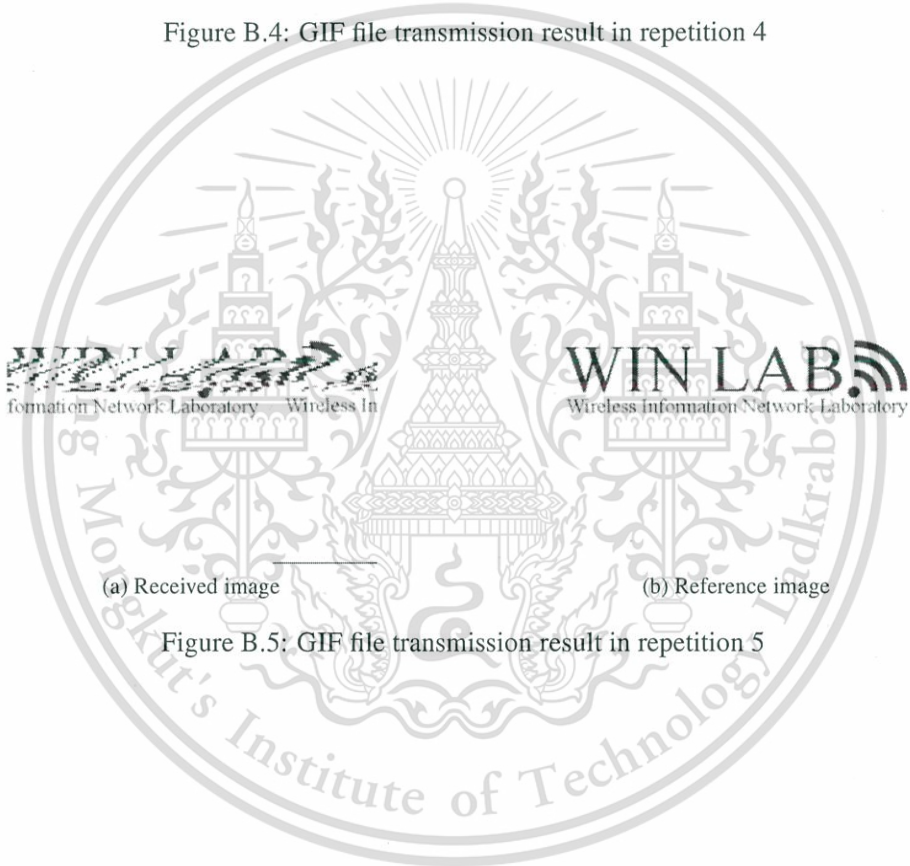

(a) Received image

(b) Reference image

Figure B.5: GIF file transmission result in repetition 5

(a) Received image

(b) Reference image

Figure B.6: GIF file transmission result in repetition 6

(a) Received image

(b) Reference image

Figure B.7: GIF file transmission result in repetition 7

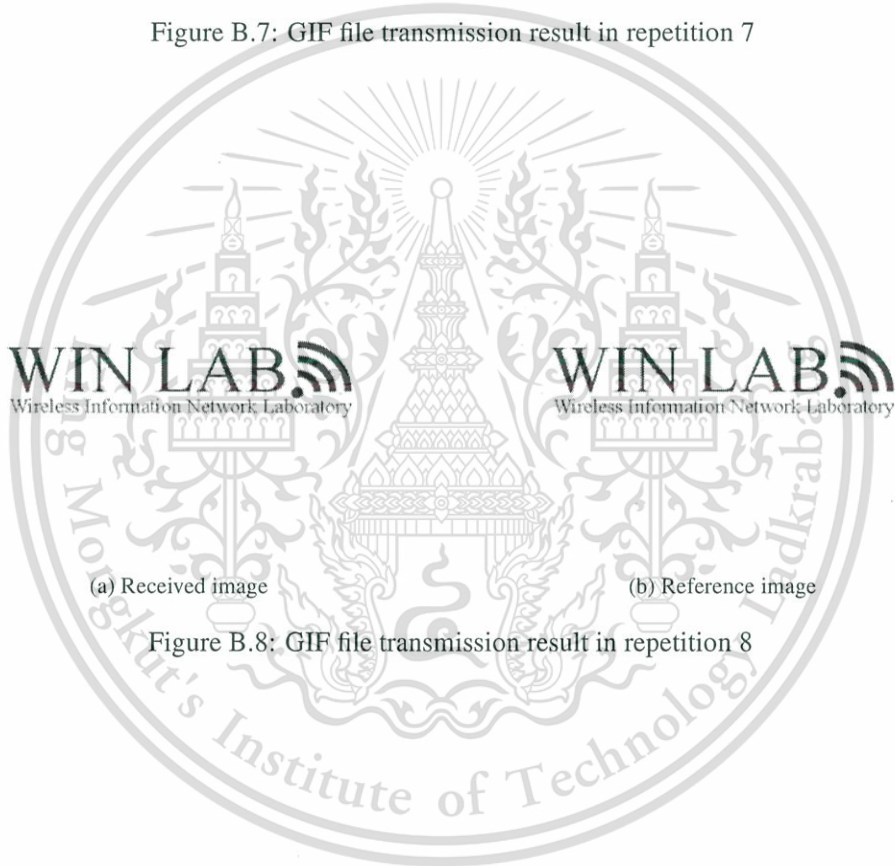

(a) Received image

(b) Reference image

Figure B.8: GIF file transmission result in repetition 8

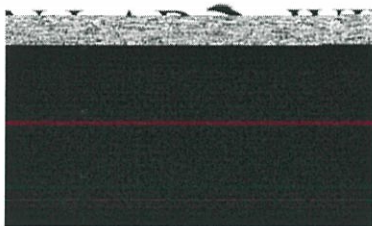

(a) Received image

(b) Reference image

Figure B.9: GIF file transmission result in repetition 9

(a) Received image

(b) Reference image

Figure B.10: GIF file transmission result in repetition 10

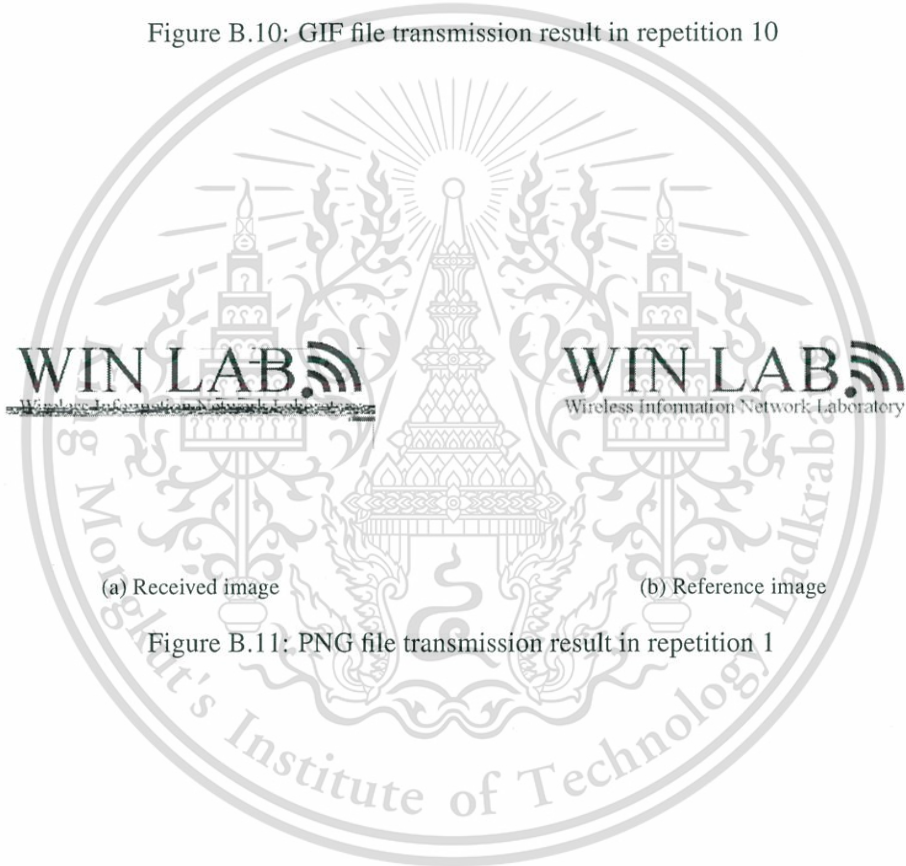

(a) Received image

(b) Reference image

Figure B.11: PNG file transmission result in repetition 1

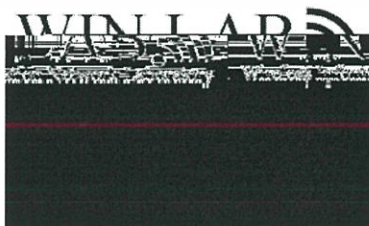

(a) Received image



(b) Reference image

Figure B.12: PNG file transmission result in repetition 2

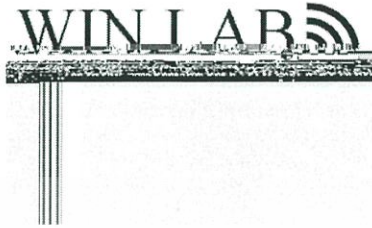

(a) Received image



(b) Reference image

Figure B.13: PNG file transmission result in repetition 3



(a) Received image



(b) Reference image

Figure B.14: PNG file transmission result in repetition 4



(a) Received image



(b) Reference image

Figure B.15: PNG file transmission result in repetition 5



(a) Received image



(b) Reference image

Figure B.16: PNG file transmission result in repetition 6



(a) Received image



(b) Reference image

Figure B.17: PNG file transmission result in repetition 7



(a) Received image



(b) Reference image

Figure B.18: PNG file transmission result in repetition 8

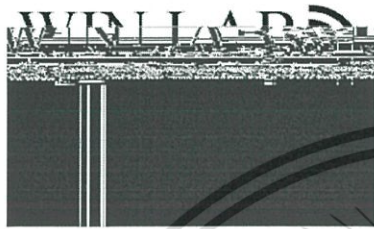

(a) Received image



(b) Reference image

Figure B.19: PNG file transmission result in repetition 9

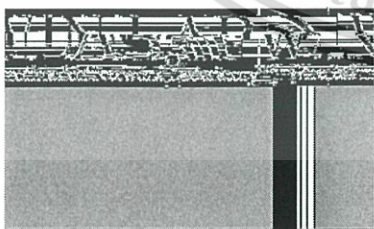

(a) Received image



(b) Reference image

Figure B.20: PNG file transmission result in repetition 10

APPENDIX C

DOCUMENT FILE RESULTS

C.1 Excel File Results

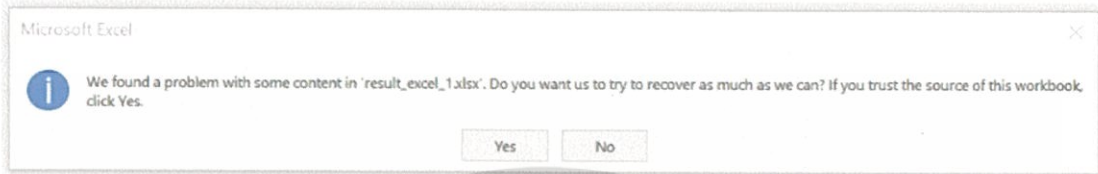

Figure C.1: Result of Excel file in repetition 1 that needs a recovery process



Figure C.2: Result of Excel file in repetition 1 after the recovery process

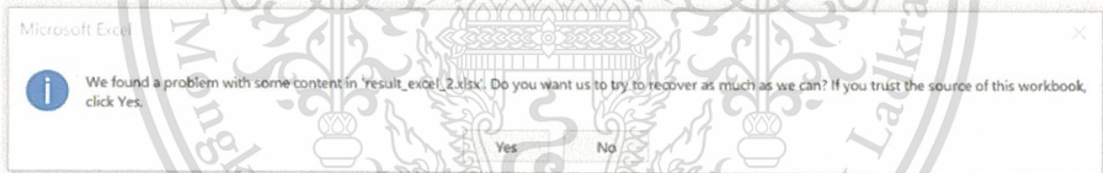

Figure C.3: Result of Excel file in repetition 2 that needs a recovery process

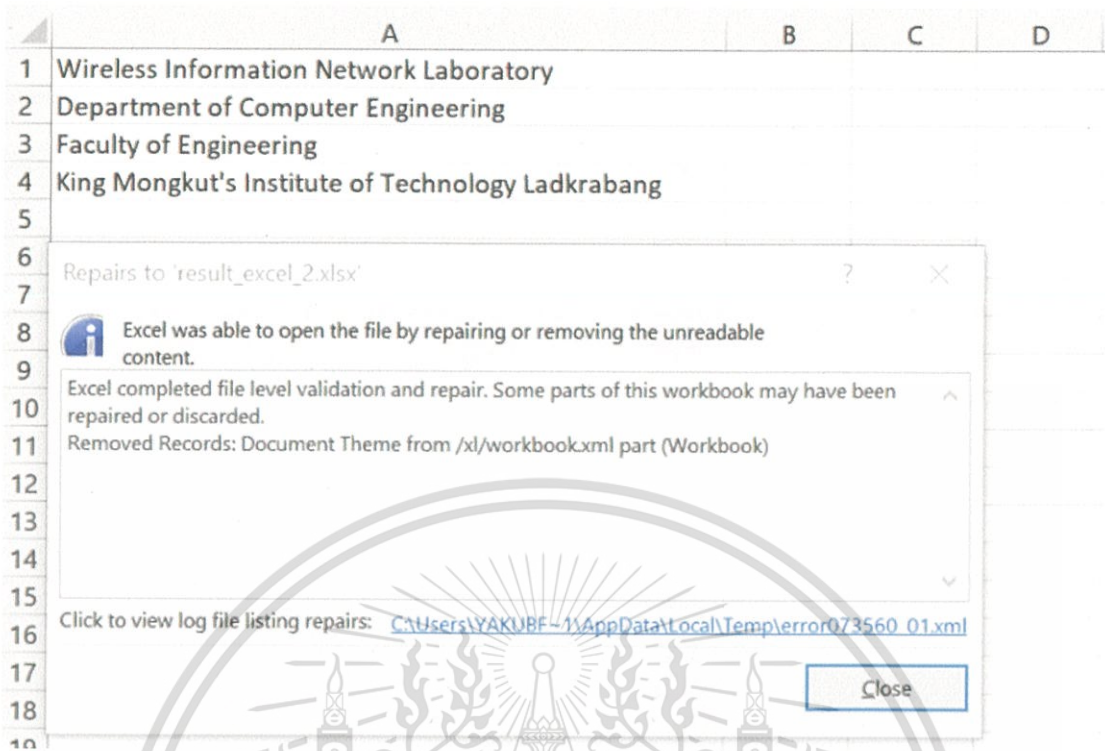

Figure C.4: Result of Excel file in repetition 2 after the recovery process



Figure C.5: Result of Excel file in repetition 3 that needs a recovery process

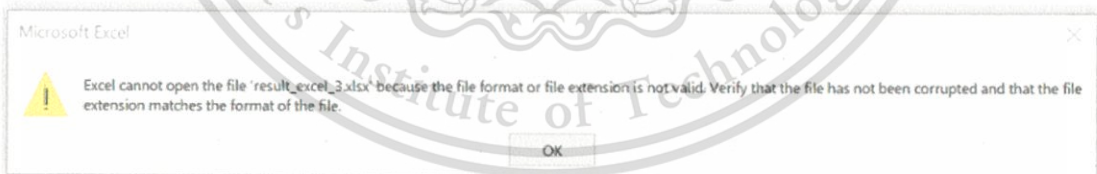

Figure C.6: Result of Excel file in repetition 3 after the recovery process

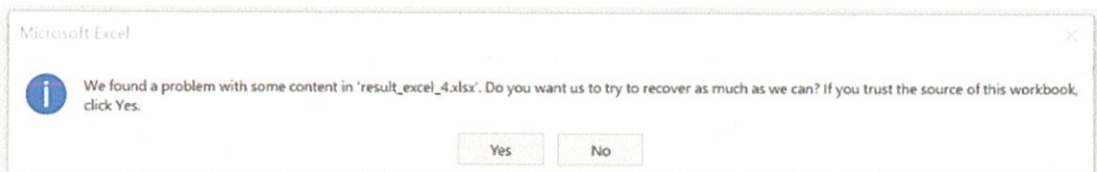

Figure C.7: Result of Excel file in repetition 4 that needs a recovery process

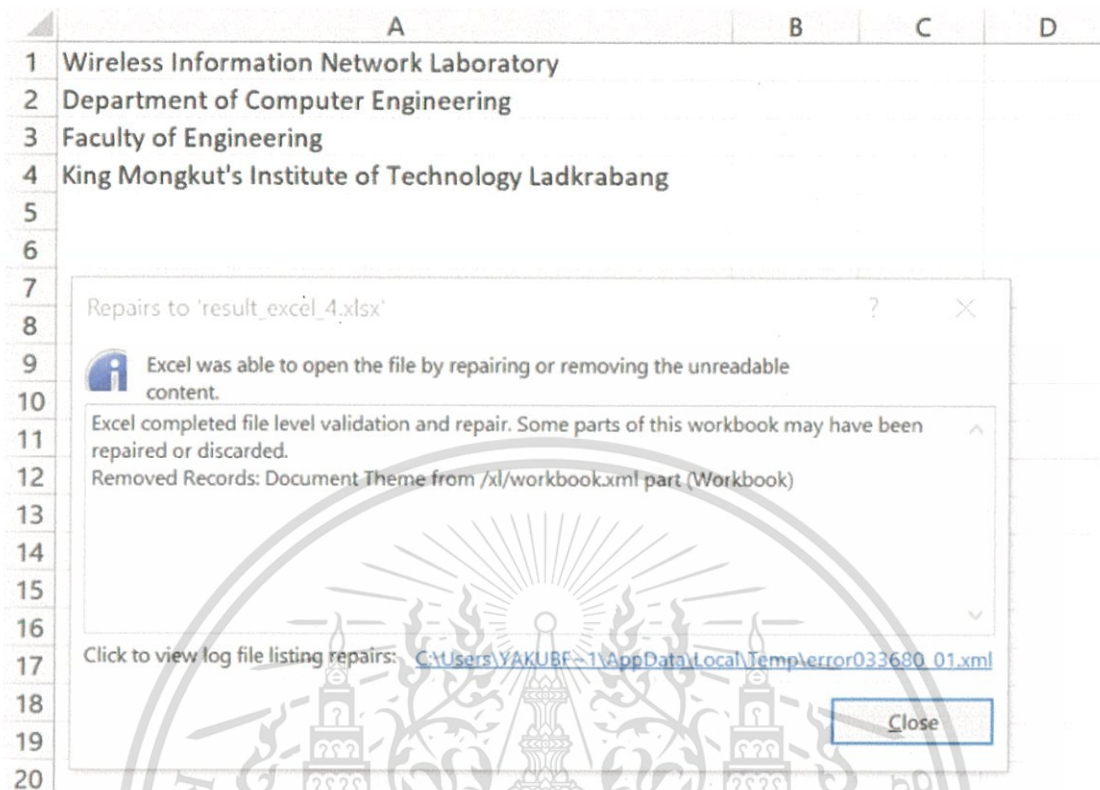

Figure C.8: Result of Excel file in repetition 4 after the recovery process



Figure C.9: Result of Excel file in repetition 5 that needs a recovery process

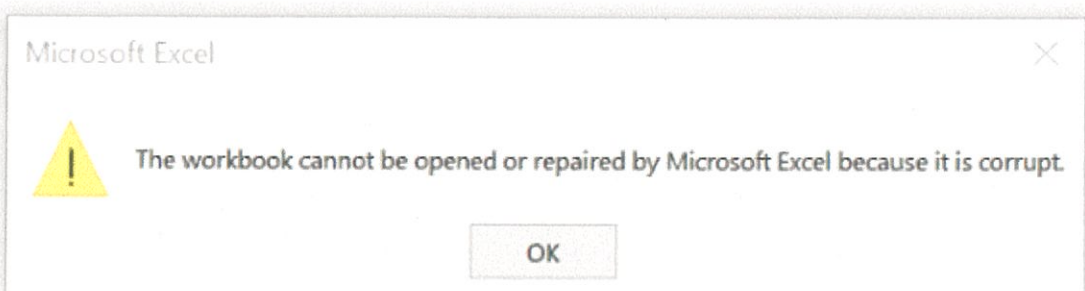

Figure C.10: Result of Excel file in repetition 5 after the recovery process

This material is reserved for educational use only, not allowed for commercial use.

Forbidden to modify the content, and cite the document when use.

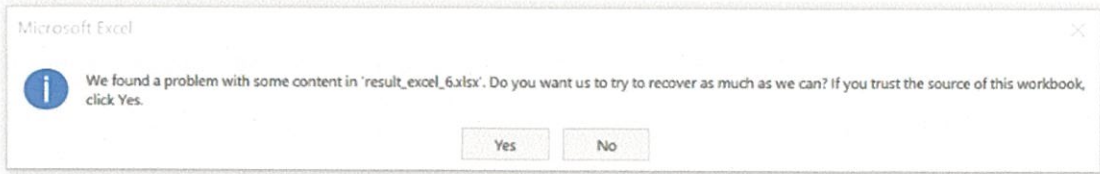

Figure C.11: Result of Excel file in repetition 6 that needs a recovery process

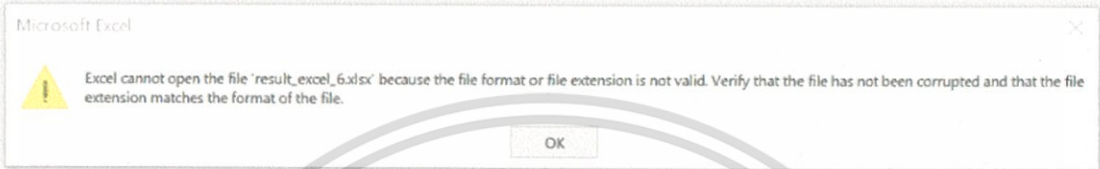

Figure C.12: Result of Excel file in repetition 6 after the recovery process

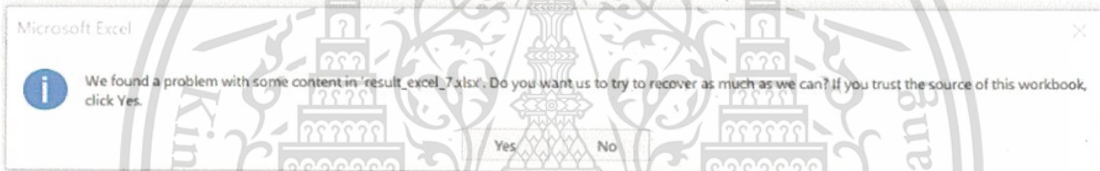

Figure C.13: Result of Excel file in repetition 7 that needs a recovery process



Figure C.14: Result of Excel file in repetition 7 after the recovery process

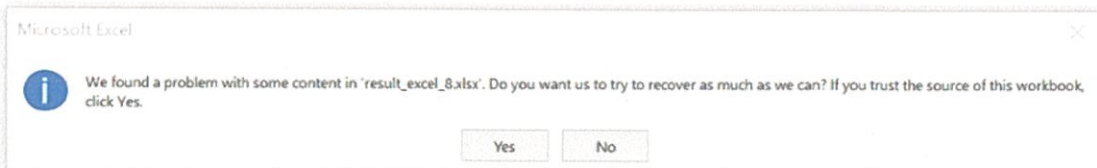

Figure C.15: Result of Excel file in repetition 8 that needs a recovery process

This material is reserved for educational use only, not allowed for commercial use.

Forbidden to modify the content, and cite the document when use.



Figure C.16: Result of Excel file in repetition 8 after the recovery process



Figure C.17: Result of Excel file in repetition 9 that needs a recovery process

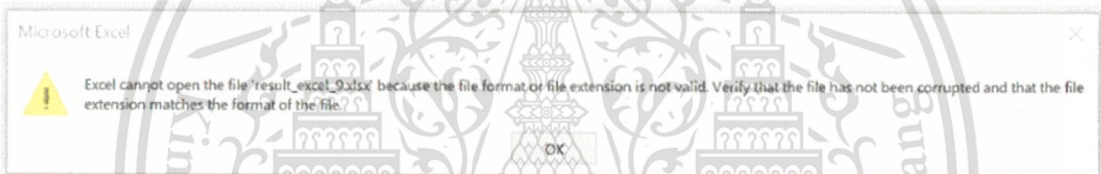

Figure C.18: Result of Excel file in repetition 9 after the recovery process



Figure C.19: Result of Excel file in repetition 10 that needs a recovery process

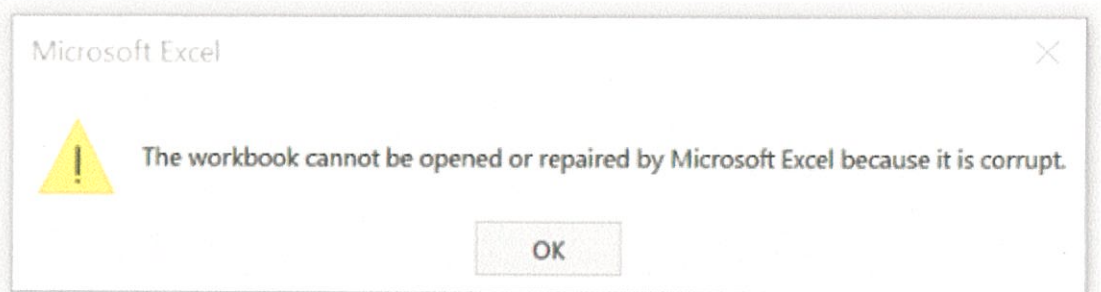

Figure C.20: Result of Excel file in repetition 10 after the recovery process

This material is reserved for educational use only, not allowed for commercial use.

Forbidden to modify the content, and cite the document when use.

C.2 Word File Results

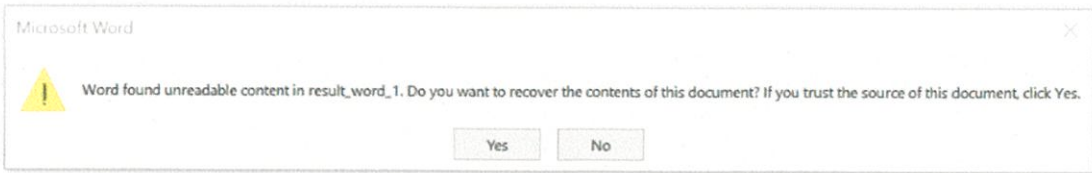

Figure C.21: Result of Word file in repetition 1 that needs a recovery process

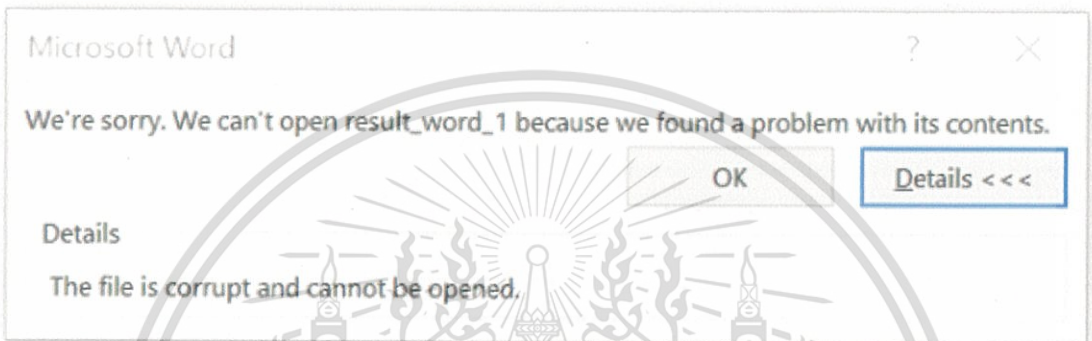

Figure C.22: Result of Word file in repetition 1 after the recovery process



Figure C.23: Result of Word file in repetition 2 that needs a recovery process

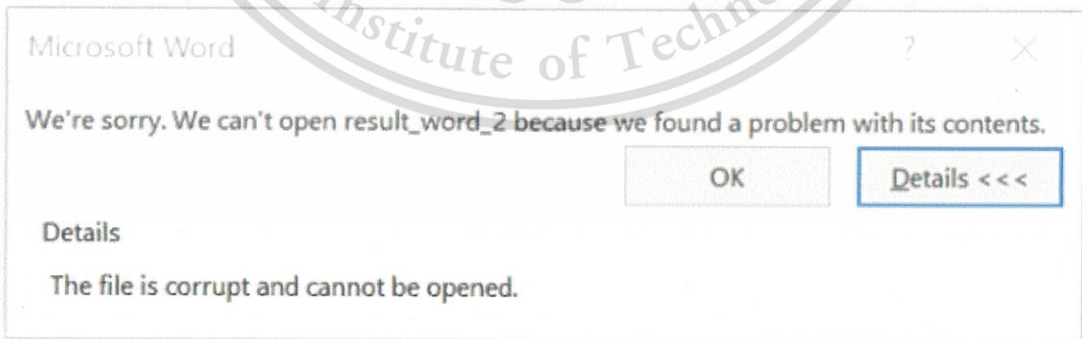

Figure C.24: Result of Word file in repetition 2 after the recovery process



Figure C.25: Result of Word file in repetition 3 that needs a recovery process

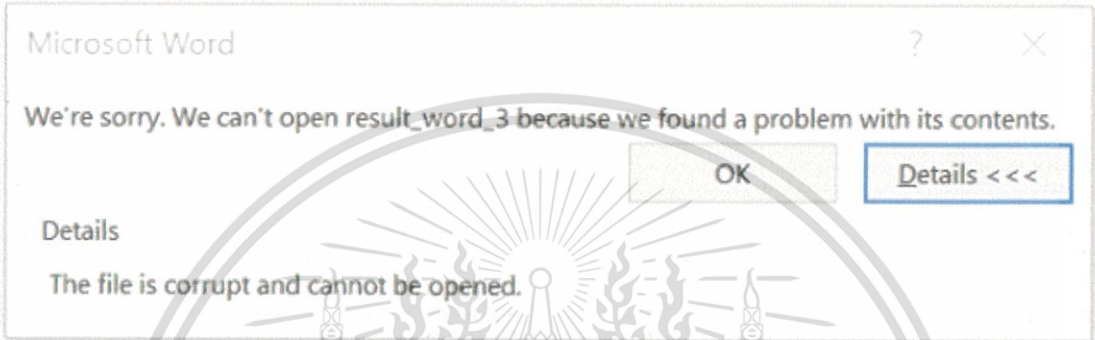

Figure C.26: Result of Word file in repetition 3 after the recovery process



Figure C.27: Result of Word file in repetition 4 that needs a recovery process

Wireless Information Network Laboratory

Department of Computer Engineering

Faculty of Engineering

King Mongkut's Institute of Technology Ladkrabang

Figure C.28: Result of Word file in repetition 4 after the recovery process

This material is reserved for educational use only, not allowed for commercial use.

Forbidden to modify the content, and cite the document when use.



Figure C.29: Result of Word file in repetition 5 that needs a recovery process

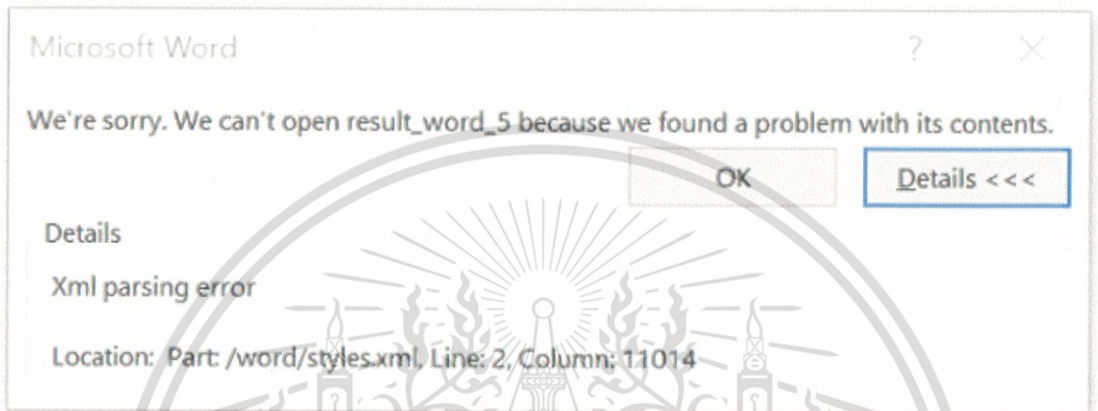

Figure C.30: Result of Word file in repetition 5 after the recovery process

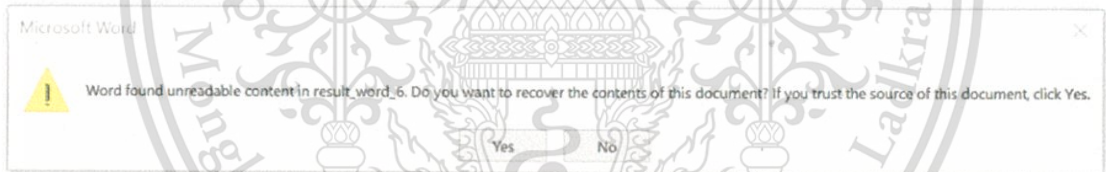

Figure C.31: Result of Word file in repetition 6 that needs a recovery process

Wireless Information Network Laboratory

Department of Computer Engineering

Faculty of Engineering

King Mongkut's Institute of Technology Ladkrabang

Figure C.32: Result of Word file in repetition 6 after the recovery process

This material is reserved for educational use only, not allowed for commercial use.

Forbidden to modify the content, and cite the document when use.



Figure C.33: Result of Word file in repetition 7 that needs a recovery process

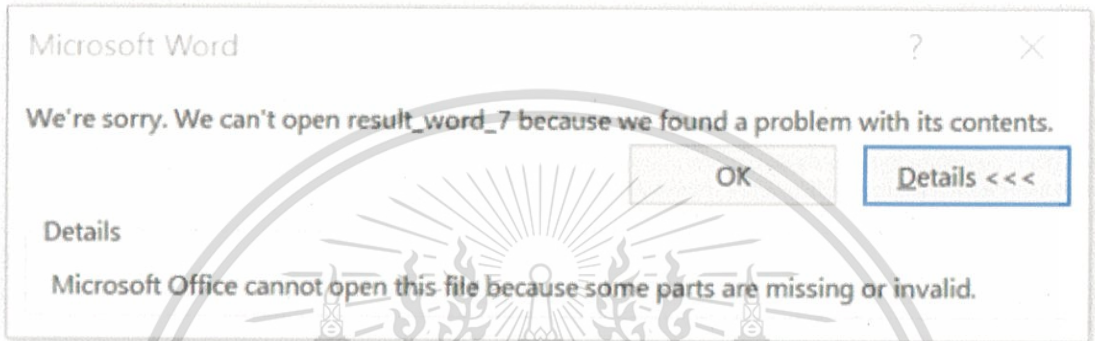

Figure C.34: Result of Word file in repetition 7 after the recovery process



Figure C.35: Result of Word file in repetition 8 that needs a recovery process

Wireless Information Network Laboratory

Department of Computer Engineering

Faculty of Engineering

King Mongkut's Institute of Technology Ladkrabang

Figure C.36: Result of Word file in repetition 8 after the recovery process

This material is reserved for educational use only, not allowed for commercial use.

Forbidden to modify the content, and cite the document when use.



Figure C.37: Result of Word file in repetition 9 that needs a recovery process

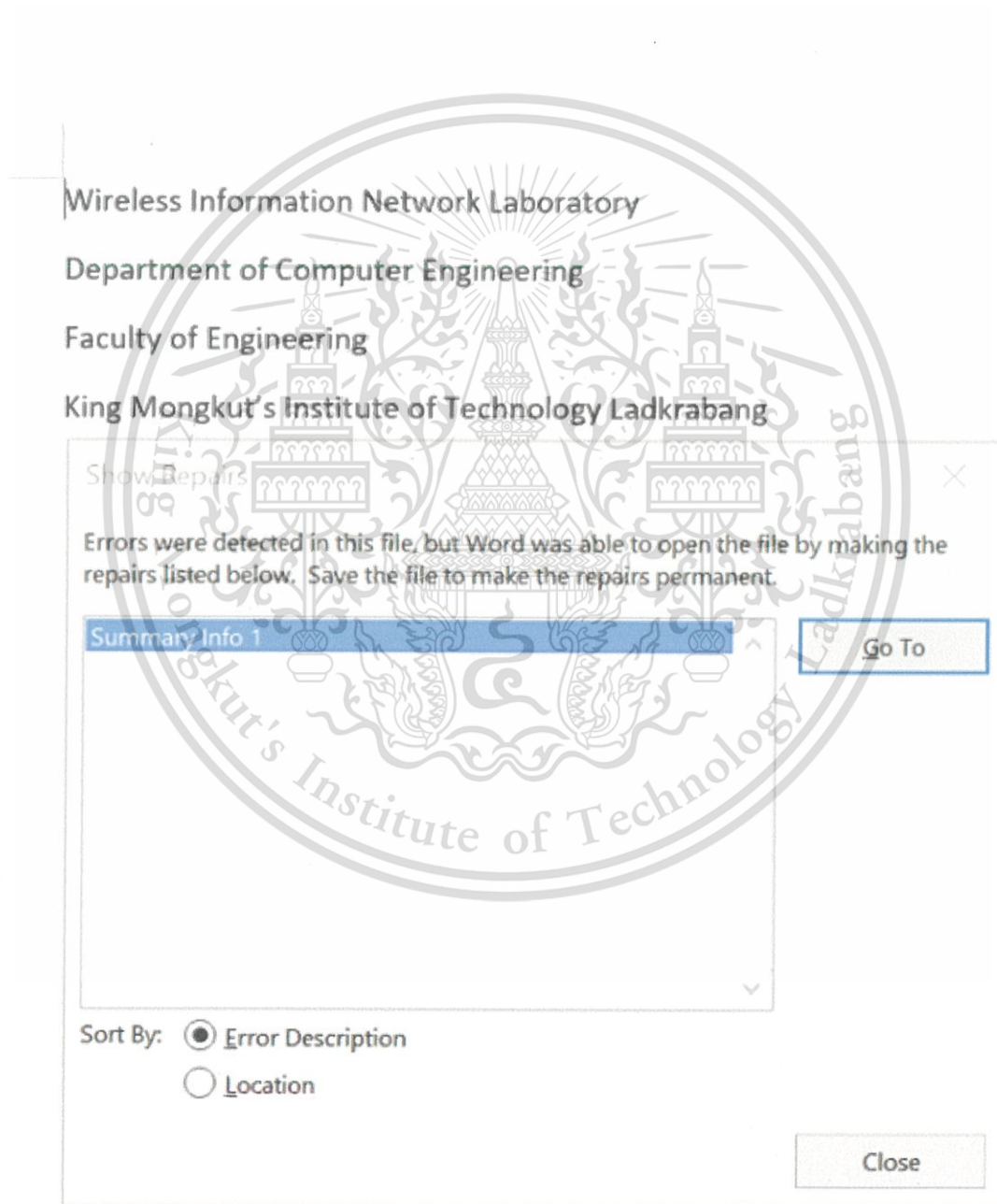

Figure C.38: Result of Word file in repetition 9 after the recovery process

This material is reserved for educational use only, not allowed for commercial use.

Forbidden to modify the content, and cite the document when use.

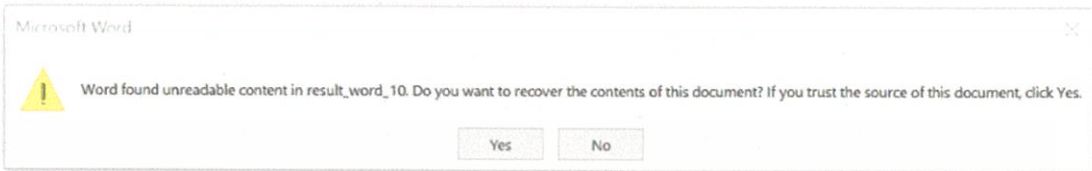

Figure C.39: Result of Word file in repetition 10 that needs a recovery process



Figure C.40: Result of Word file in repetition 10 after the recovery process

C.3 PDF File Results

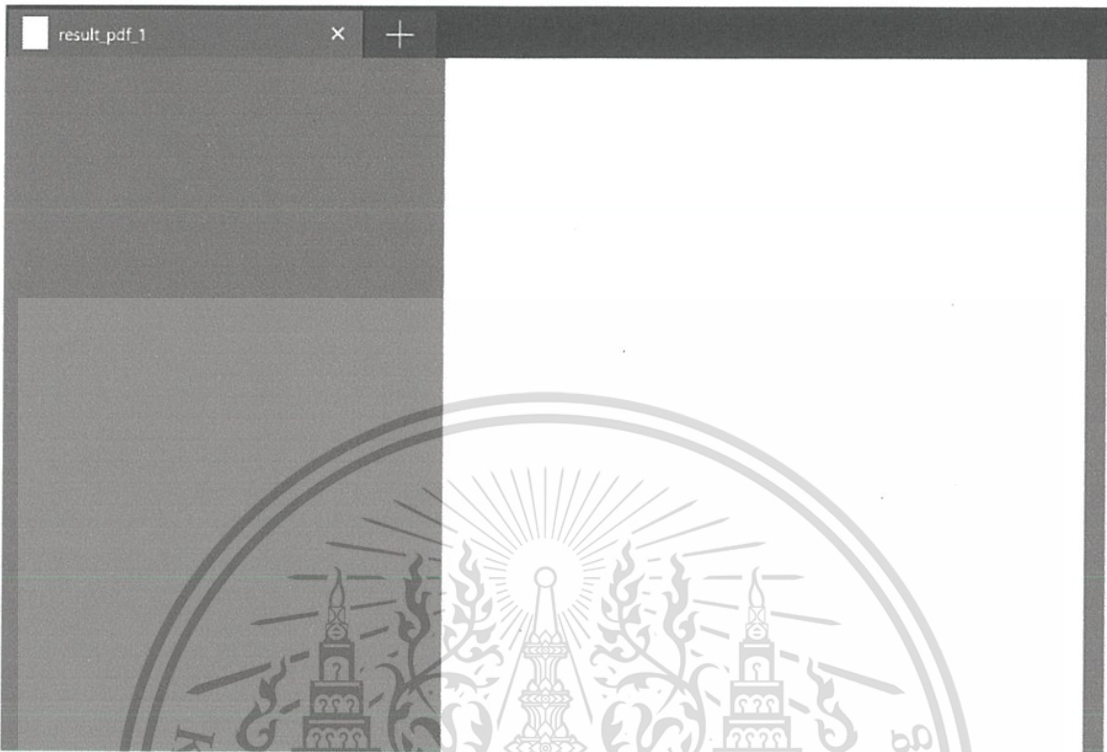

Figure C.41: Result of PDF file in repetition 1 after through the recovery process



Figure C.42: Result of PDF file in repetition 2 after through the recovery process

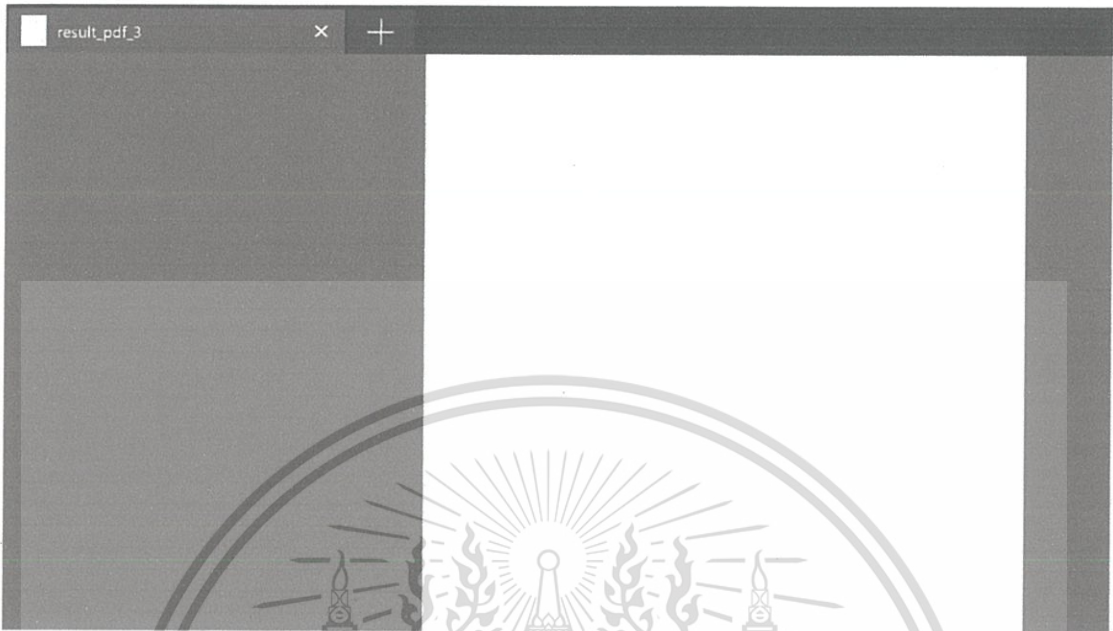

Figure C.43: Result of PDF file in repetition 3 after through the recovery process

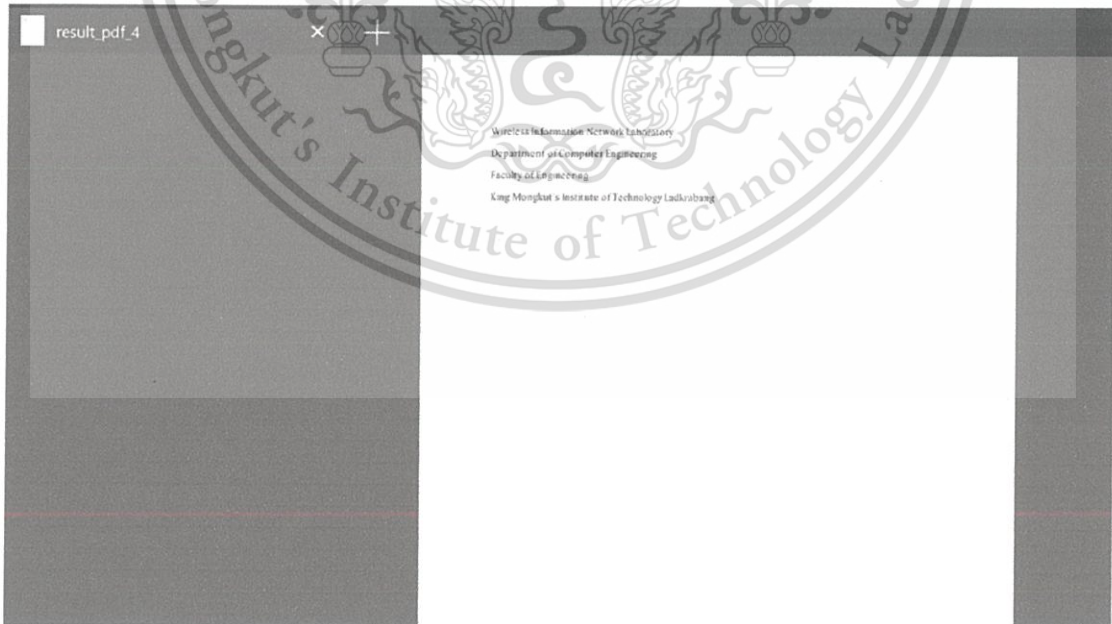

Figure C.44: Result of PDF file in repetition 4 after through the recovery process

This material is reserved for educational use only, not allowed for commercial use.

Forbidden to modify the content, and cite the document when use.

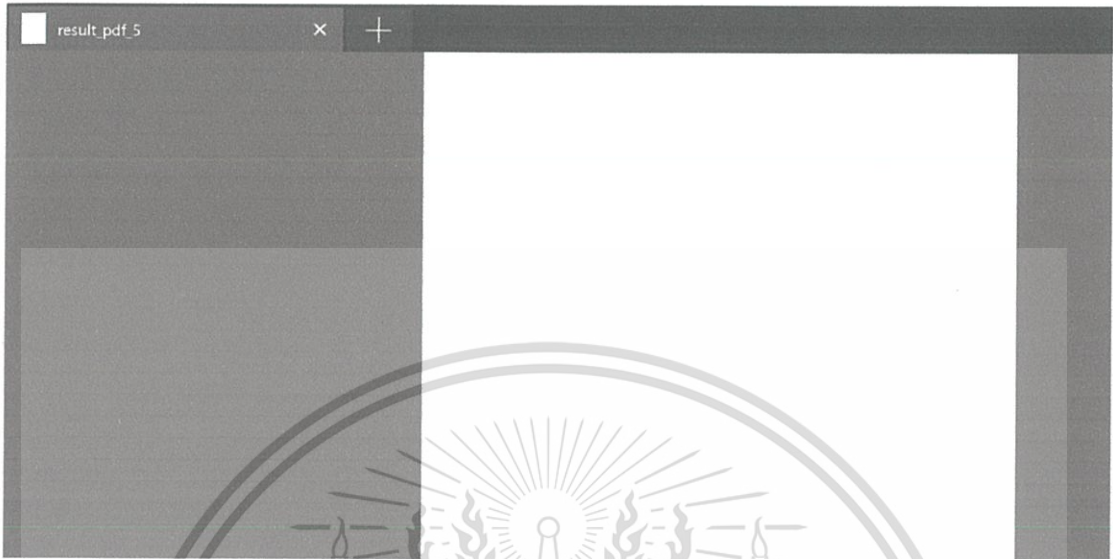

Figure C.45: Result of PDF file in repetition 5 after through the recovery process

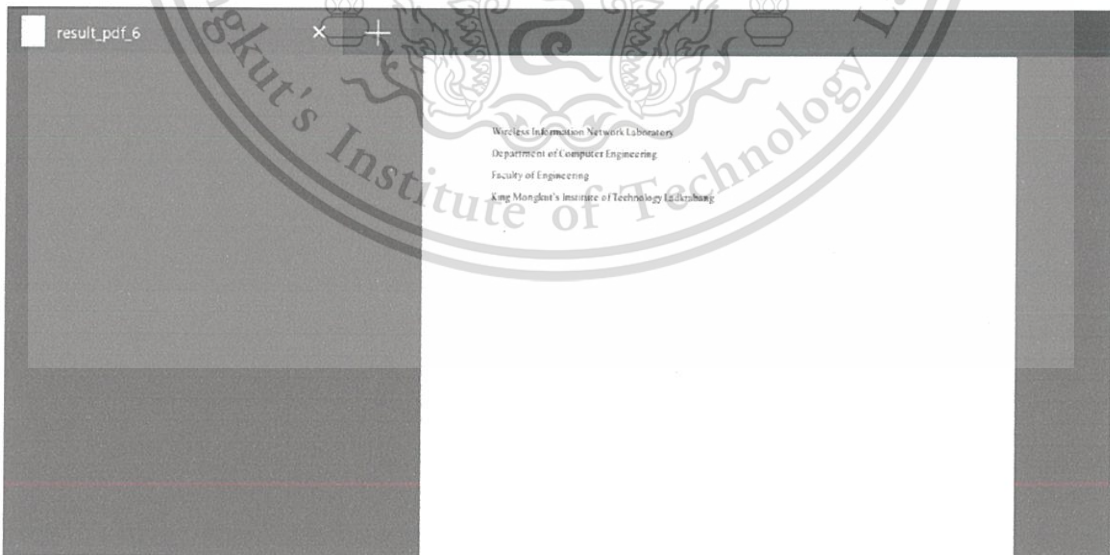

Figure C.46: Result of PDF file in repetition 6 after through the recovery process

This material is reserved for educational use only, not allowed for commercial use.

Forbidden to modify the content, and cite the document when use.

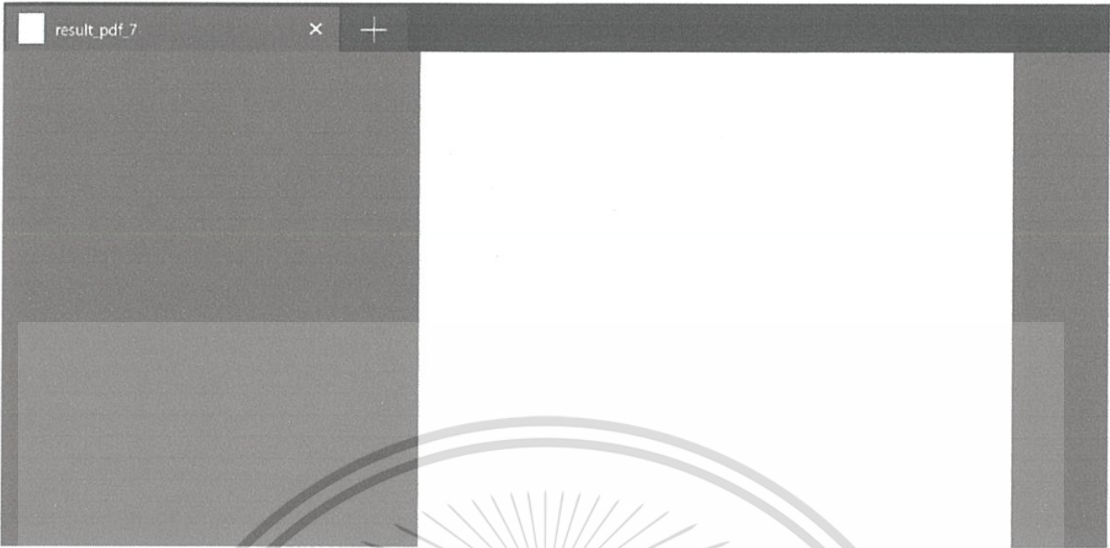

Figure C.47: Result of PDF file in repetition 7 after through the recovery process



Figure C.48: Result of PDF file in repetition 8 after through the recovery process

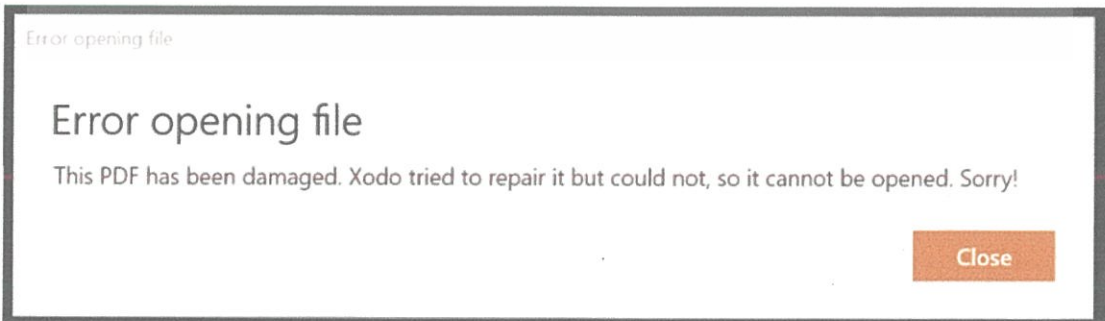

Figure C.49: Result of PDF file in repetition 9 after through the recovery process

This material is reserved for educational use only, not allowed for commercial use.

Forbidden to modify the content, and cite the document when use.

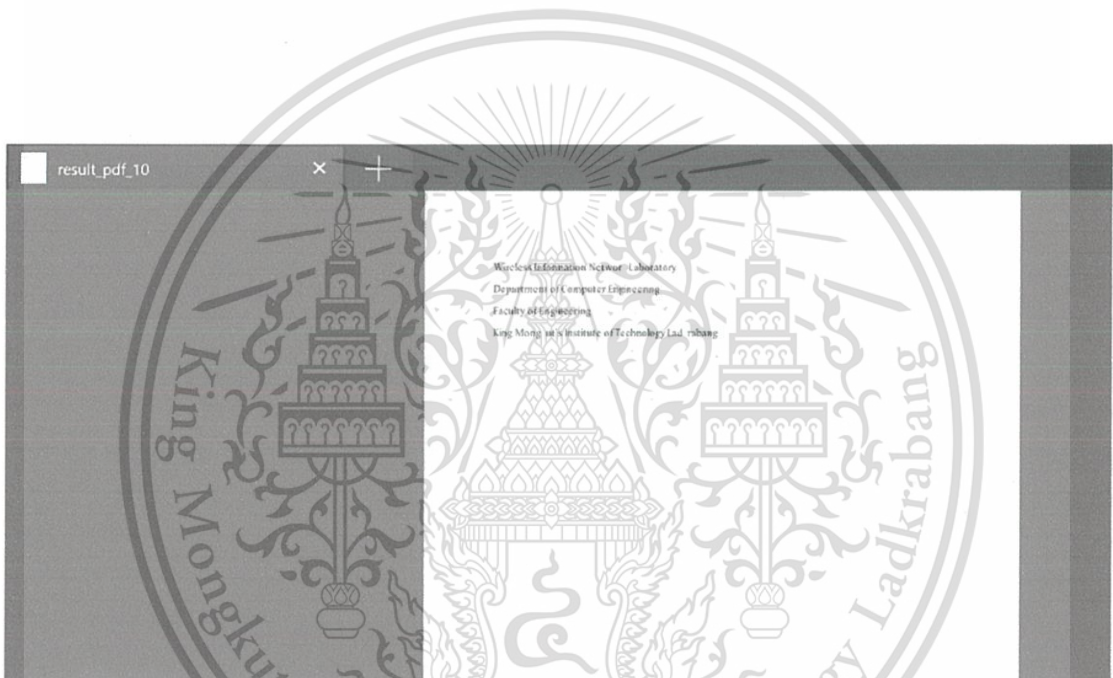

Figure C.50: Result of PDF file in repetition 10 after through the recovery process

C.4 PowerPoint File Results

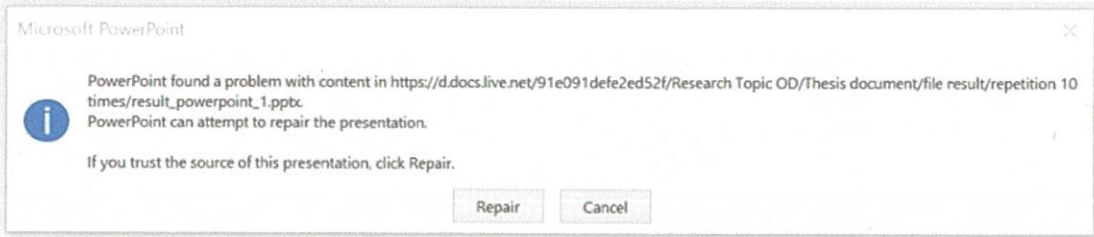

Figure C.51: Result of PowerPoint file in repetition 1 that needs a recovery process

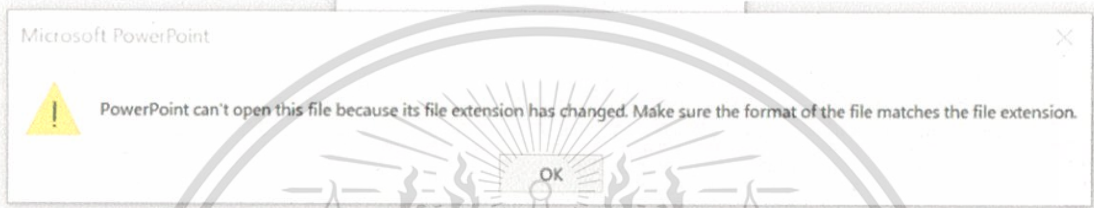

Figure C.52: Result of PowerPoint file in repetition 1 after the recovery process



Figure C.53: Result of PowerPoint file in repetition 2 that needs a recovery process

Department of Computer Engineering
Wireless Information Network Laboratory

- Faculty of Engineering
- King Mongkut's Institute of Technology Ladkrabang

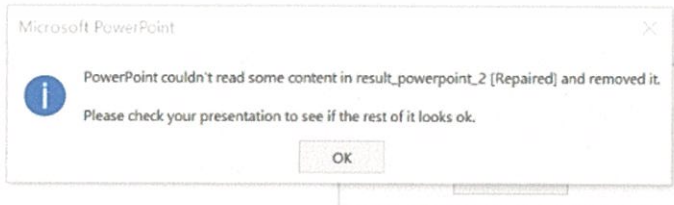

Figure C.54: Result of PowerPoint file in repetition 2 after the recovery process

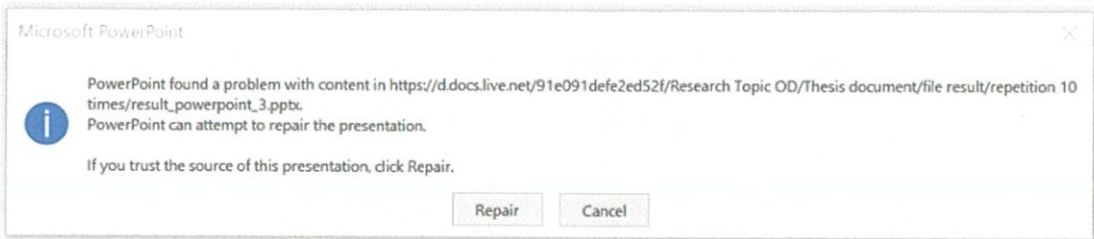

Figure C.55: Result of PowerPoint file in repetition 3 that needs a recovery process



Figure C.56: Result of PowerPoint file in repetition 3 after the recovery process

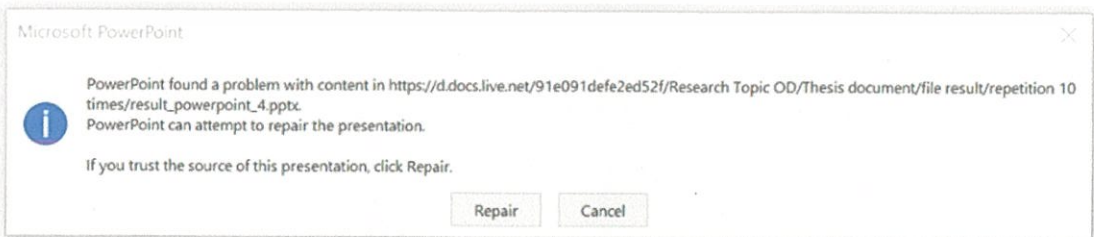

Figure C.57: Result of PowerPoint file in repetition 4 that needs a recovery process



Department of Computer Engineering
Faculty of Engineering
King Mongkut's Institute of Technology Ladkrabang

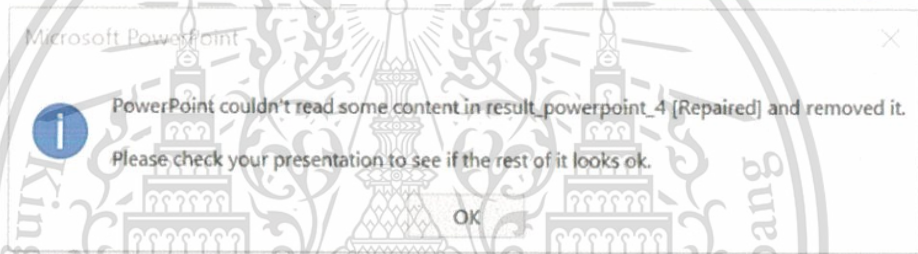

Figure C.58: Result of PowerPoint file in repetition 4 after the recovery process

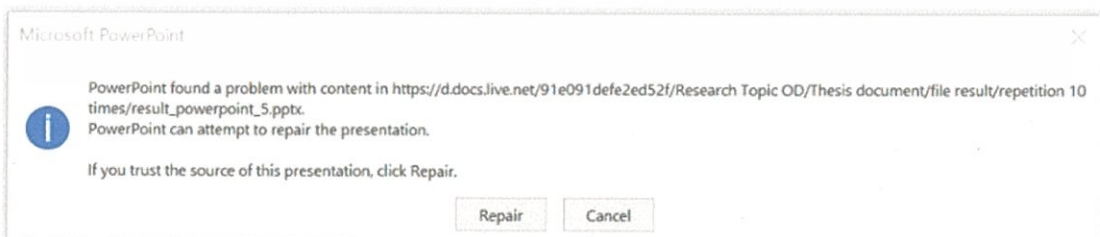

Figure C.59: Result of PowerPoint file in repetition 5 that needs a recovery process



Department of Computer Engineering
Faculty of Engineering

King Mongkut's Institute of Technology Ladkrabang

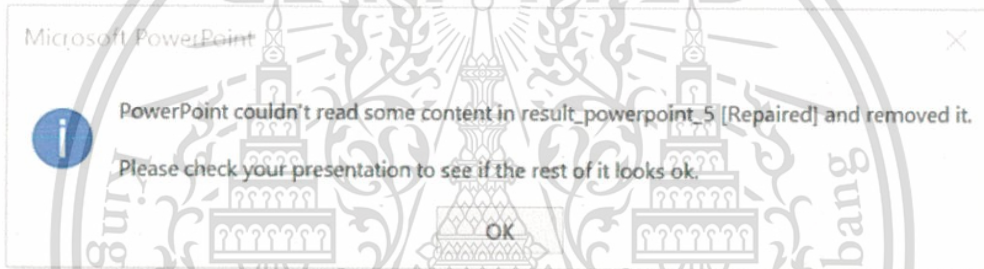

Figure C.60: Result of PowerPoint file in repetition 5 after the recovery process

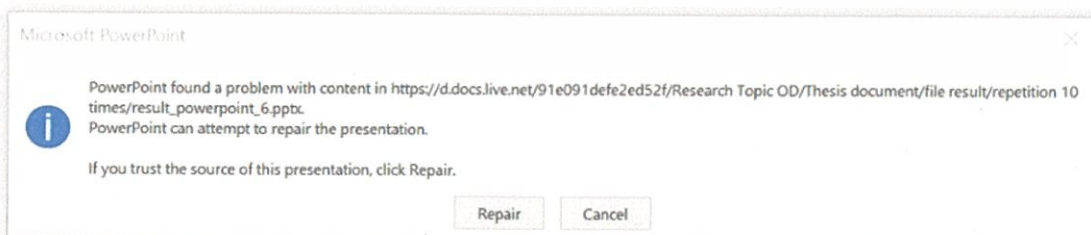

Figure C.61: Result of PowerPoint file in repetition 6 that needs a recovery process

W M Information Laboratory

Department of Computer Engineering

Faculty of Engineering

King Mongkut's Institute of Technology Ladkrabang

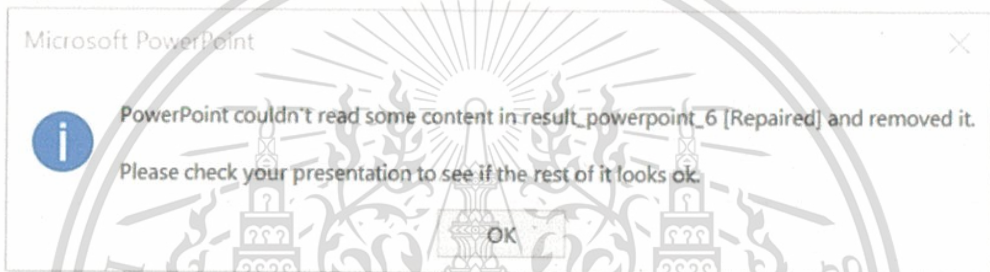

Figure C.62: Result of PowerPoint file in repetition 6 after the recovery process



Figure C.63: Result of PowerPoint file in repetition 7 that needs a recovery process



Figure C.64: Result of PowerPoint file in repetition 7 after the recovery process

This material is reserved for educational use only, not allowed for commercial use.

Forbidden to modify the content, and cite the document when use.

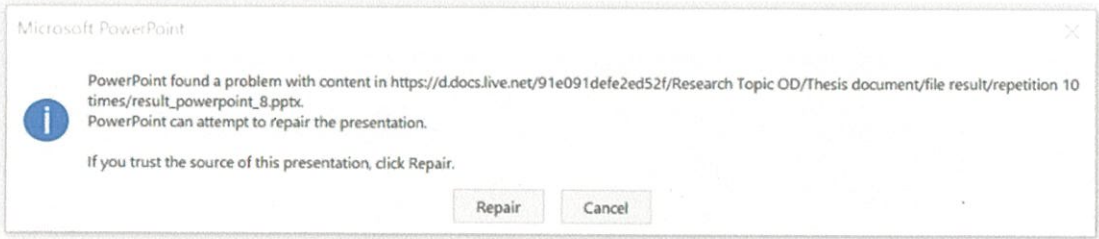

Figure C.65: Result of PowerPoint file in repetition 8 that needs a recovery process

Department of Computer Engineering
Wireless Information Network Laboratory
• Faculty of Engineering
• King Mongkut's Institute of Technology Ladkrabang

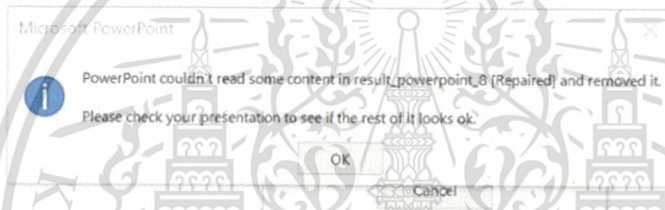

Figure C.66: Result of PowerPoint file in repetition 8 after the recovery process

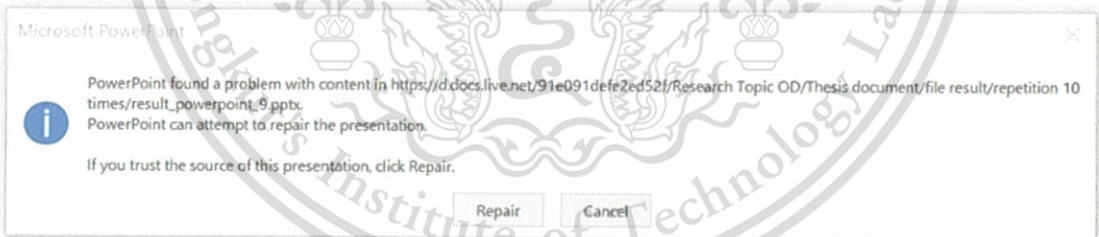

Figure C.67: Result of PowerPoint file in repetition 9 that needs a recovery process



Figure C.68: Result of PowerPoint file in repetition 9 after the recovery process

This material is reserved for educational use only, not allowed for commercial use.

Forbidden to modify the content, and cite the document when use.

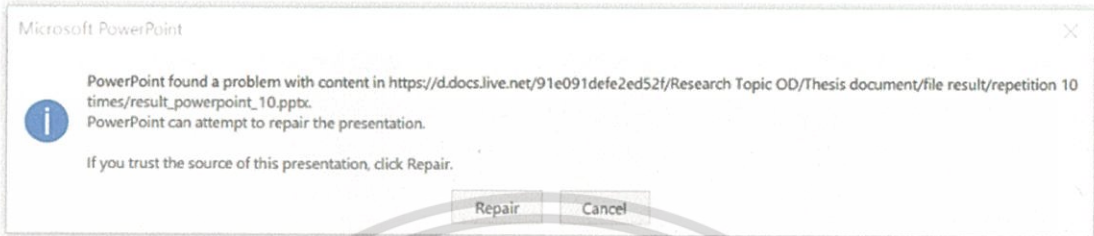

Figure C.69: Result of PowerPoint file in repetition 10 that needs a recovery process



Figure C.70: Result of PowerPoint file in repetition 10 after the recovery process

C.5 Text File Results

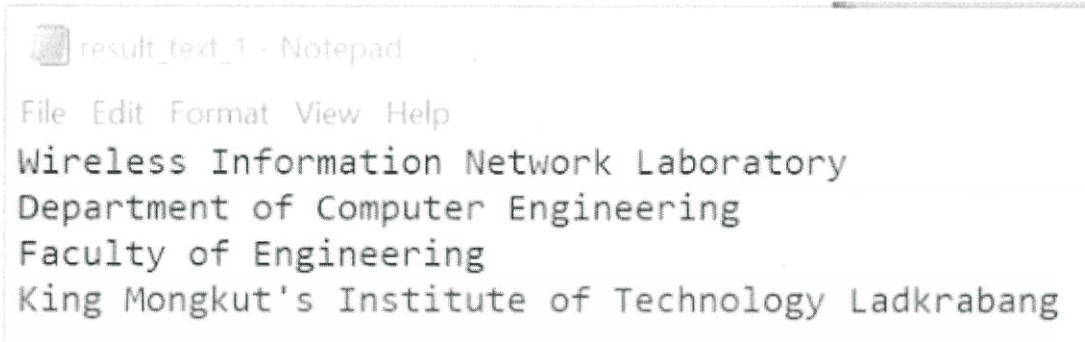

Figure C.71: Result of Text file in repetition 1



Figure C.72: Result of Text file in repetition 2

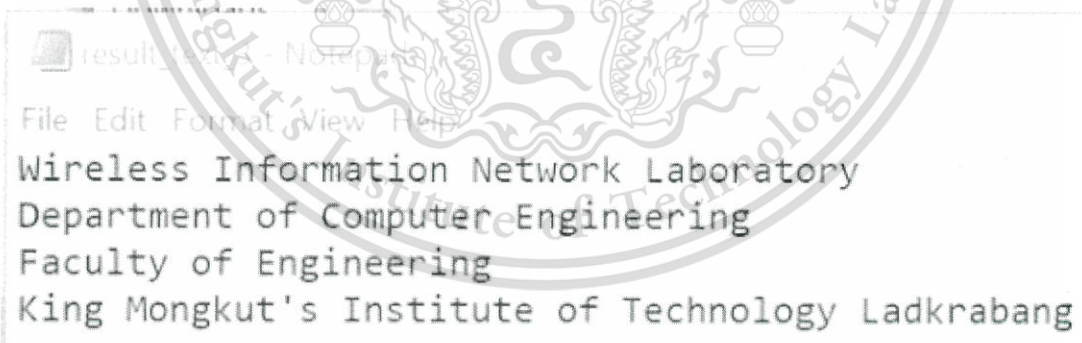

Figure C.73: Result of Text file in repetition 3

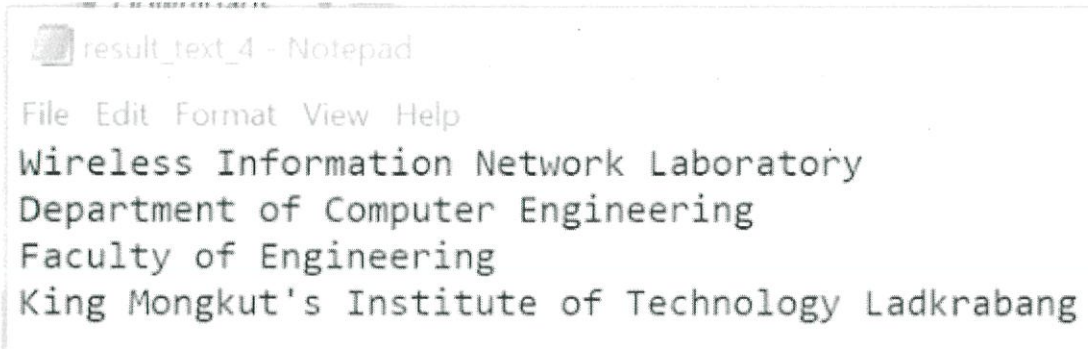

Figure C.74: Result of Text file in repetition 4

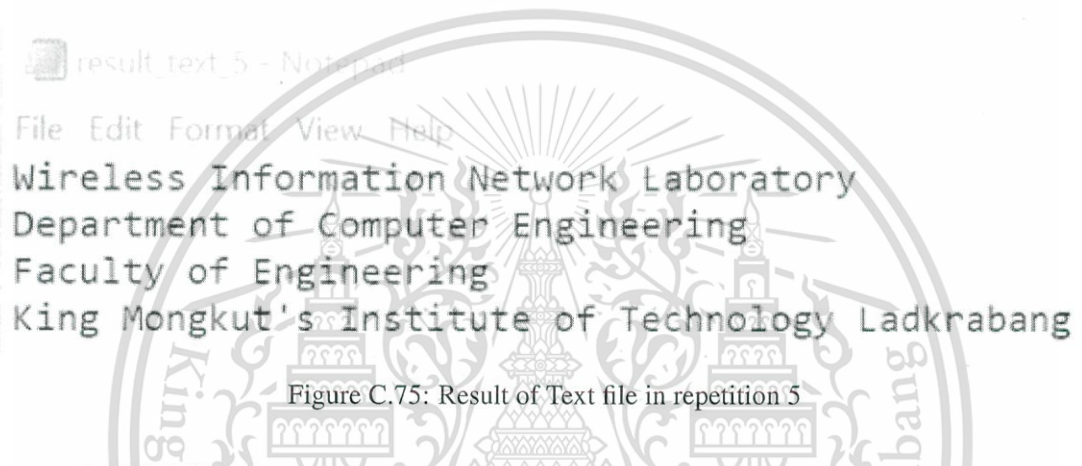

Figure C.75: Result of Text file in repetition 5



Figure C.76: Result of Text file in repetition 6

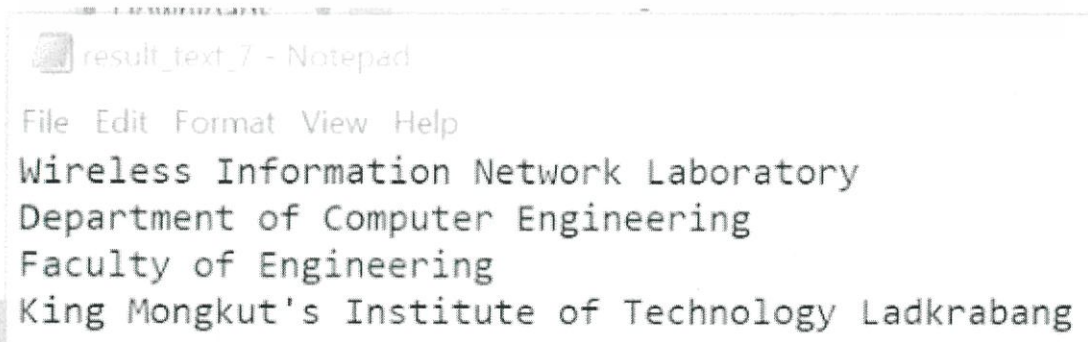

Figure C.77: Result of Text file in repetition 7

This material is reserved for educational use only, not allowed for commercial use.

Forbidden to modify the content, and cite the document when use.

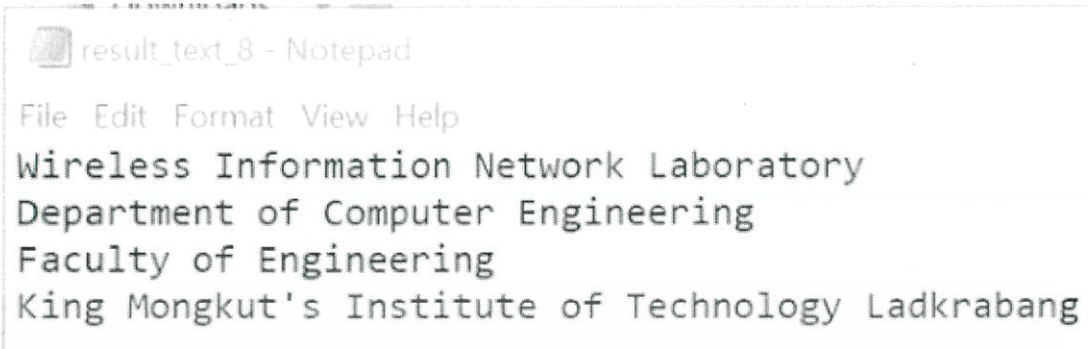

Figure C.78: Result of Text file in repetition 8

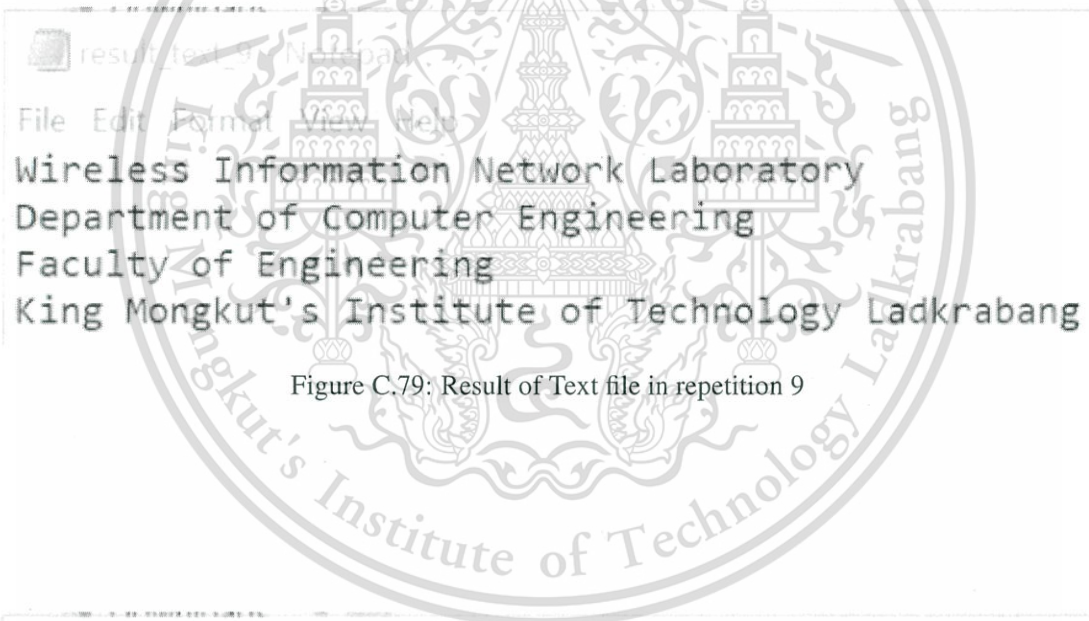

Figure C.79: Result of Text file in repetition 9

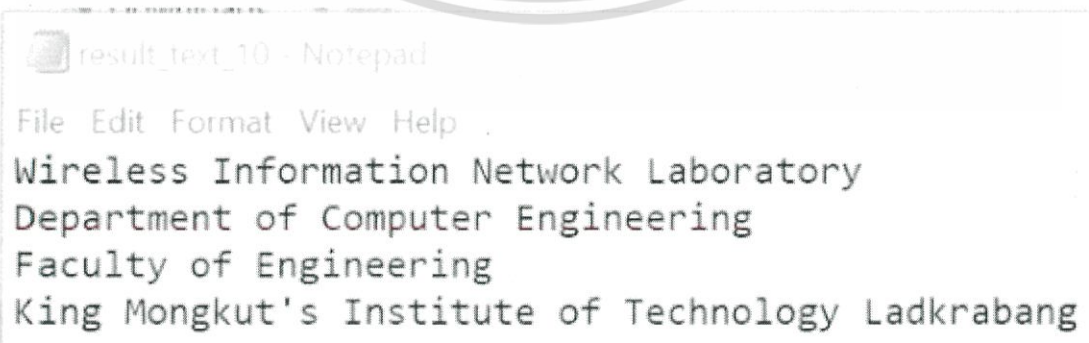

Figure C.80: Result of Text file in repetition 10

BIOGRAPHY

Personal Information

Name	Yakub Fahim Luckyarno
Sex	Male
Nationality	Indonesian
Date of Birth	30 July, 1992
Place of Birth	Sleman, Yogyakarta, Indonesia

Education

Bachelor degree

Project	Design and development of posturometry using Programmable System-on-Chip (PSoC)
Field of Study	Engineering Physics
Duration	2010-2014
Department	Department Nuclear Engineering & Engineering Physics
University	Universitas Gadjah Mada

Master degree

Thesis	Performance Investigation of Visible Light Communication Network
Field of Study	Wireless Communication Network
Duration	2015-2017
College	International College
University	King Mongkut's Institute of Technology Ladkrabang, Bangkok, Thailand

Research Interests

Instrumentation, embedded system and signal processing

LIST OF PUBLICATIONS

Some parts of this work are published in the following articles.

Regional Conference Proceedings

1. Yakub Fahim Luckyarno and Panarat Cherntanomwong and Chaiwat Nuthong “Real-time Vital Sign Transmission using VLC” AUN/SEED-Net Regional Conference on Computer and Information Engineering(RCCIE 2016). Yangon, MYANMAR, Oct 3-4, 2016.

International Conference

1. Yakub Fahim Luckyarno and Panarat Cherntanomwong and Rony Wijaya “Posturometry data transmission using visible light communication” 13th International Conference on Electrical Engineering/Electronics, Computer, Telecommunications and Information Technology (ECTI-CON). Chiang Mai, Thailand, June 28- July 1 2016.

